

Prinoth[®]

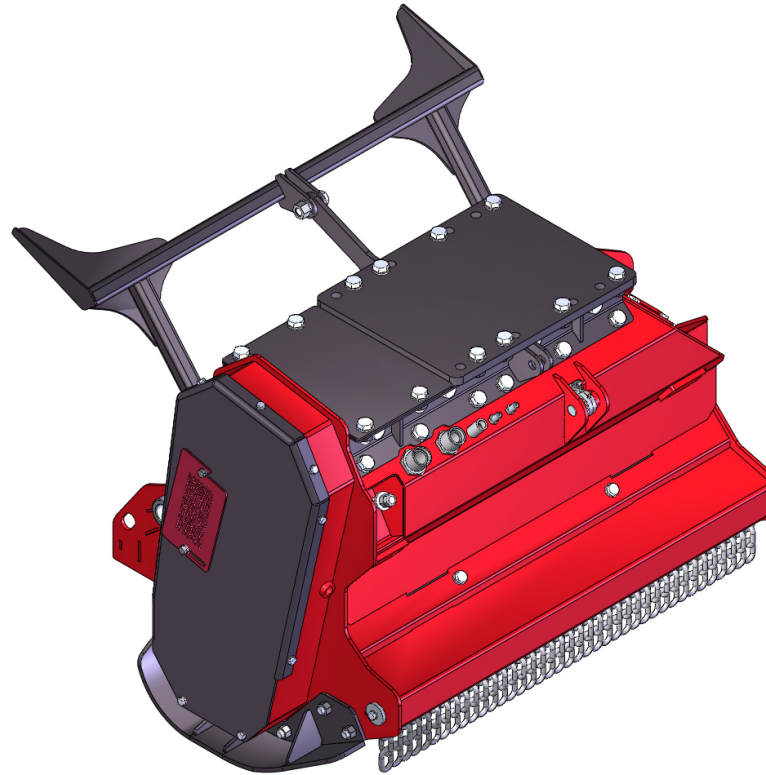

Ersatzteilliste / Spare Parts List / Catalogue pièces / каталог запасных частей

Mulchfräse

Serial-Nr.: M450E-1100-VERS02

PRINOTH GmbH - Im Branden 15 - D-88634 Herdwangen
Fon +49 (0) 7557 9212-0
prinoth.germany@prinoth.com - www.prinoth.com

Aufbau der Ersatzteillisten / Layout of parts lists / Conception des listes de pièces détachées / Структура списков запасных частей:

Die Ersatzteilliste ist in Hauptbaugruppen und Unterbaugruppen aufgeteilt. Zu den Positions-Nummern auf den Bildtafeln finden Sie in der Stückliste das betreffende Prinoth Ersatzteil.

Achten Sie auf die Mengenangabe jeder übergeordneten Baugruppe um die Gesamtmenge pro Maschine zu ermitteln.

Die Bestellmenge, die in der übergeordneten Baugruppe angegeben ist, multipliziert sich also mit der Mengenangabe der untergeordneten Bauteile.

Spare parts lists are divided into primary assemblies and secondary assemblies. Prinoth spare parts are listed in bills of material numbered according to the item numbers you can see in the illustrations.

Take care when specifying the quantity for each higher-level (primary) assembly, as this number is used to calculate the total number of items for each machine. The order quantity specified for the higher-level (primary) assembly is multiplied by the number of lower-level (secondary) components specified.

La liste des pièces détachées est divisée en unités principales et en unités secondaires. Les numéros de position des tableaux illustrés vous indiquent dans la liste de pièces la pièce détachée Prinoth correspondante.

Tenez compte de l'indication de quantité de chaque unité supérieure afin de déterminer la quantité globale par machine.

La quantité à commander, indiquée dans l'unité supérieure, se multiplie donc par l'indication de quantité des composants inférieurs.

Списки запасных частей подразделяются на основные и подчиненные узлы. В спецификации по номерам позиции, указанным на выносках чертежа, вы найдете

соответствующую запасную часть фирмы Prinoth.

Для определения общего количества на каждую машину воспользуйтесь количеством, указанным в каждом подчиненном узле.

Таким образом, заказываемое количество, указанное в узле более высокого уровня, необходимо умножить на указанное количество подчиненных деталей.

BEISPIEL: „Riemenübersetzung“ mit Untergruppenbauteil „Keilriemenscheibe“ / EXAMPLE: “Belt transmission” with “V-belt pulley” as a secondary component /
EXEMPLE : « transmission par courroie » avec unité secondaire « poulie à gorge pour courroie trapézoïdale » / ПРИМЕР: «Ременная передача» с деталью «Клиноременный шкив» подчиненного узла

Mulchfräse M550-2110 - Mulcher M550-2110 broyeur forestier M550-2110 - Лесные фрезы M550-2110		551.00.00.00/A Stücklistennummer / Piece Number / Liste de Pièces / Номер				
Pos.	Bausatz-Nr. Stock Number Numéro de Commande Номер товара	Menge Amount Quantité Количество	Beschreibung	Description	Description	Описание
12	650.02.06.03.00	2	Seitengelenkwelle	Side shaft w. friction clutch	cardan latéral	карданный вал
13	650.02.04.00.00/D	2	Riemenübersetzung	Belt transmission i 1,13	transmission	переход ремня
14	650.02.04.01.00/D	2	Riemenübersetzung	Belt transmission i 1,0	transmission	переход ремня

Riemenübersetzung - Belt transmission i 1,0 transmission - переход ремня		650.02.04.01.00/D Stücklistennummer / Piece Number / Liste de Pièces / Номер				
Pos.	Bausatz-Nr. Stock Number Numéro de Commande Номер товара	Menge Amount Quantité Количество	Beschreibung	Description	Description	Описание
1	48.01.300.4	2	Keilriemenscheibe	V-Belt Pulley 300x4	poulie à gorge pour courroie trapézoïdale	Шкив клиноременной передачи
2	49.65.3020	1	Taperlock	Taperlock-Bushing Ø 65 /3020	moyeu de serrage	Запорная коническая втулка
3	49.60.3020	1	Taperlock	Taperlock-Bushing Ø 50 /3020	moyeu de serrage	Запорная коническая втулка

2x Riemenübersetzung = 2x2 Keilriemenscheiben → Bestellwert 4 Stück!!

2x belt transmission = 2x2 V-belt pulley → Order value 4 items!!

2x transmission par courroie = 2x2 poulies à gorge pour courroie trapézoïdale → Quantité à commander 4 pièces !!

2x ременных передачи = 2x2 клиноременных шкива → Заказываемое значение 4 штуки!!

Configuration

Maschine/ machine: M450e-1100

Materialnummer/ material number: 32025773

Materialnummer/ material number	Version	Materialbeschreibung	Material description
470.01.00.00.00	02	GEHAEUSE M450E - 1100 GESCHRAUBT	GEHAEUSE M450E - 1100 GESCHRAUBT
857.03.00.67.00	B	ROTOR D450 1100 24XBCS	ROTOR D450 1100 24XBCS
460.03.00.00.00	A	LABYRINTHDICHTUNG BCS ROTOR	LABYRITH SEAL RING FOR BCS
470.02.04.00.00	A	RIEMENUEBERSETZUNG I=0,89	BELT RATIO I=0,89
470.02.00.00.00	01	ANTRIEB HYDRAULISCH	HYDRAULIC DRIVE
470.15.00.00.00	04	HYDRAULIKKOMPONENTEN KOMPLETT-DKOL	HYDRAULIC COMPONENTS ASSY-DKOL
450.06.00.00.00	00	KUFEN OHNE UNTERSCHNITT SATZ M450	SKIDS
470.10.03.00.00	00	DECKEL WENN OHNE Klappe	DECKEL WENN OHNE Klappe
470.07.00.00.00	A	DRUECKEVORRICHTUNG KLAPPENS. KOMPLET	PUSH-BAR ON FLAP SIDE
470.32.01.00.00	00	ADAPTERPLATTE GESCHRAUBT	INTERFACE
450.11.00.00.00	03	PRODUKTGRAFIK	PRODUCT GRAPHICS
551.01.00.90.00	00	TYPENSCHILD + NIETEN	TYPENSCHILD + NIETEN
991.40.16.00.00	00	HOLZTRANSPORTGESTELL 1400X800X280	HOLZTRANSPORTGESTELL 1400X800X280
470.80.00.00.02		BA-ENGLISCH + ET-LISTE DIG M450e-1100	BA-ENGLISCH + ET-LISTE DIGITAL
61.2.01.001	00	HYDRAULIKOEL -36 BIS 234GC	HYDRAULIKOEL -36 BIS 234GC
61.1.05	00	LUBCON-TURMOGREASE-LI802EP	LUBCON GREASE LI802EP

1	M450E - 1100 / M450E - 1100 / M450E - 1100.....	6
1.1	LABYRINTHDICHTUNG BCS ROTOR / LABYRITH SEAL RING FOR BCS / LABYRITH SEAL RING FOR BCS.....	12
1.2	ROTOR D450 1100 24XUPTS / ROTOR D450 1100 24XUPTS / ROTOR D450 1100 24XUPTS.....	16
1.2.1	ROTORGRUNDKOERPER MIT HALTER / ROTORGRUNDKOERPER MIT HALTER / ROTORGRUNDKOERPER MIT HALTER.....	18
1.2.2	ROTORSTUMMEL KURZ / ROTOR SHOFT / ROTOR SHOFT.....	20
1.2.3	WERKZEUG UPTS05 / TOOL UPTS05 / OUTIL UPTS05.....	22
1.2.4	WERKZEUG UPTS06 / TOOL UPTS06 / OUTIL UPTS06.....	26
1.3	LABYRINTHDICHTUNG UPTS ROTOR / LABYRITH SEAL RING FOR UPTS / LABYRITH SEAL RING FOR UPTS.....	30
1.4	ROTOR D450 1100 30XHDT02.A / ROTOR D450 1100 30XHDT02.A / ROTOR D450 1100 30XHDT02.A.....	34
1.4.1	ROTOR M450H GESCHWEISST / ROTOR M450H WELDED / ROTOR M450H WELDED.....	38
1.4.2	ROTORSTUMMEL KURZ / ROTOR SHOFT / ROTOR SHOFT.....	42
1.5	ROTOR D450 1100 30XHDT01.A / ROTOR D450 1100 30XHDT01.A / ROTOR D450 1100 30XHDT01.A.....	44
1.5.1	ROTOR M450H GESCHWEISST / ROTOR M450H WELDED / ROTOR M450H WELDED.....	48
1.5.2	ROTORSTUMMEL KURZ / ROTOR SHOFT / ROTOR SHOFT.....	52
1.6	ROTOR D450 1100 GEMISCHT / ROTOR M450H MIXED / ROTOR M450H MIXED.....	54
1.6.1	ROTOR M450H GESCHWEISST / ROTOR M450H WELDED / ROTOR M450H WELDED.....	58
1.6.2	ROTORSTUMMEL KURZ / ROTOR SHOFT / ROTOR SHOFT.....	62
1.7	ROTOR D450 1100 30XHDT04.V / ROTOR D450 1100 30XHDT04.V / ROTOR D450 1100 30XHDT04.V.....	64
1.7.1	ROTOR M450H GESCHWEISST / ROTOR M450H WELDED / ROTOR M450H WELDED.....	66
1.7.2	ROTORSTUMMEL KURZ / ROTOR SHOFT / ROTOR SHOFT.....	70
1.8	LABYRINTHDICHTUNG HDT ROTOR / LABYRINTH SEAL RING FOR HDT / LABYRINTH SEAL RING FOR HDT.....	72
1.9	KUFEN OHNE UNTERSCHNITT SATZ M450 / SKIDS / SKIDS.....	74
1.10	KLAPPE-GESCHRAUBT / SHUTTER-SCREWED / CLAPET-VISSE.....	76
1.10.1	KLAPPE GESCHWEISST / Klappe geschweisst / Klappe geschweisst.....	80
1.10.2	SCHMIERSCHRAUBE M16X25 M.SCH. / GREASE SCREW M16X25 / GREASE SCREW M16X25.....	82
1.10.3	HYDRAULIK-ZYLINDER / HYDR. CYLINDER / HYDR. CYLINDER.....	86
1.11	DRUECKEVORRICHTUNG KLAPPENS. KOMPLETT / PUSH-BAR ON FLAP SIDE / PUSH-BAR ON FLAP SIDE.....	88
1.12	DRUECKEVORRICHTUNG KETTENSEITIG KOMPLETT / PUSH-BAR ON CHAIN GUARD SIDE / PUSH-BAR ON CHAIN GUARD SIDE.....	92
1.13	DECKEL WENN OHNE Klappe / DECKEL WENN OHNE Klappe / DECKEL WENN OHNE Klappe.....	94
1.14	PRODUKTGRAFIK / PRODUCT GRAPHICS / GRAPHIQUE DU PRODUIT.....	96
1.14.1	PRODUKTGRAFIK-MULCHGERAET / PRODUCT GRAPHICS-MULCHER / GRAPHIQUE DU PRODUIT-BROYEUR.....	98
1.15	ADAPTERPLATTE GESCHRAUBT / INTERFACE / INTERFACE.....	100
1.16	TYPENSCHILD + NIETEN / TYPENSCHILD + NIETEN / TYPENSCHILD + NIETEN.....	102
1.17	HYDRAULIKKOMPONENTEN KOMPLETT-DKOL / HYDRAULIC COMPONENTS ASSY-DKOL / COMPOSANTS HYDRAULIQUES ENS-DKOL.....	104
1.17.1	DECKEL ANSCHLUSSBLOCK / DECKEL ANSCHLUSSBLOCK / DECKEL ANSCHLUSSBLOCK.....	110

1.18 ROTOR D450 1100 24XBCS / ROTOR D450 1100 24XBCS / ROTOR D450 1100 24XBCS.....	112
1.18.1 ROTOR-GESCHWEISST / ROTOR-WELDED / ROTOR-SOUDE.....	116
1.18.2 ROTORSTUMMEL KURZ / ROTOR SHOFT / ROTOR SHOFT.....	118
1.19 RIEMENUEBERSETZUNG I=1,0 / RIEMENUEBERSETZUNG I=1,0 / RIEMENUEBERSETZUNG I=1,0.....	120
1.19.1 TAPERLOCK 3020 D50 / TAPERLOCK-BUSHING D 50 /3020 / TAPERLOCK-BUSHING D 50 /3020.....	124
1.19.2 TAPERLOCK 3020 D65 / TAPERLOCK-BUSHING D 65 /3020 / TAPERLOCK-BUSHING D 65 /3020.....	126
1.19.3 KEILRIEMENSATZ KEILRIEMEN B17 1700 LW / POWERBELT SET / POWERBELT SET.....	128
1.20 RIEMENUEBERSETZUNG I=1,12 / RIEMENUEBERSETZUNG I=1,12 / RIEMENUEBERSETZUNG I=1,12.....	130
1.20.1 TAPERLOCK 3020 D50 / TAPERLOCK-BUSHING D 50 /3020 / TAPERLOCK-BUSHING D 50 /3020.....	134
1.20.2 TAPERLOCK 3020 D65 / TAPERLOCK-BUSHING D 65 /3020 / TAPERLOCK-BUSHING D 65 /3020.....	136
1.20.3 KEILRIEMENSATZ KEILRIEMEN B17 1700 LW / POWERBELT SET / POWERBELT SET.....	138
1.21 ANTRIEB HYDRAULISCH / HYDRAULIC DRIVE / HYDRAULIC DRIVE.....	140
1.21.1 HYDR.-MOTOR A6VM80 / HYDRAULIC MOTOR A6VM80 / HYDRAULIC MOTOR A6VM80.....	144
1.21.1.1 AXKO-VERSTELLMOTOR 80CCM / AXIAL PISTON MOTOR 80CC / AXIAL PISTON MOTOR 80CC.....	146
1.21.2 LOSLAGER D65X120 / LOOSE BEARING D65X120 / LOOSE BEARING D65X120.....	148
1.21.3 FESTLAGER D65X120 / FIXED BEARING D65X120 / FIXED BEARING D65X120.....	150
1.21.4 LAGERGLOCKE 4-LOCH, LK 180, DIN 5480 / BEARING UNIT / BEARING UNIT.....	152
1.21.5 FLANSCH / FLANGE / FLANGE.....	160
1.21.6 HOCHDRUCKSCHL. F.FETT 850 / GREASE LINE 850 MM LONG / GREASE LINE 850 MM LONG.....	162
1.21.6.1 HOCHDRUCKSCHLAUCH D4, D 8,6, GERADE / HIGH PRESSURE HOSE FOR GREASE / HIGH PRESSURE HOSE FOR GREASE.....	164
1.21.7 GER-EINSCHR-VERSCHR. 6L M10X1 / STRAIGHT SCREW FITTING 6L M10 / STRAIGHT SCREW FITTING 6L M10.....	166
1.22 RIEMENUEBERSETZUNG I=0,89 / BELT RATIO I=0,89 / BELT RATIO I=0,89.....	168
1.22.1 TAPERLOCK 3020 D50 / TAPERLOCK-BUSHING D 50 /3020 / TAPERLOCK-BUSHING D 50 /3020.....	176
1.22.2 TAPERLOCK 3020 D65 / TAPERLOCK-BUSHING D 65 /3020 / TAPERLOCK-BUSHING D 65 /3020.....	178
1.22.3 KEILRIEMENSATZ KEILRIEMEN B17 1700 LW / POWERBELT SET / POWERBELT SET.....	180
1.22.4 DISTANZRING D75X4,5X4 / DISTANCE RING / DISTANCE RING.....	182
1.22.5 DISTANZRING D75X4,5X9 / DISTANCE RING / DISTANCE RING.....	186
1.23 GEHAEUSE M450E - 1100 GESCHRAUBT / GEHAEUSE M450E - 1100 GESCHRAUBT / GEHAEUSE M450E - 1100 GESCHRAUBT.....	190
1.23.1 KETTENVORHANG / KETTENVORHANG / KETTENVORHANG.....	194
1.23.2 DECKEL-GESCHRAUBT M450 / COVER-SCREWED M450 / COUVERCLE-VISSE M450.....	196
1.23.2.1 LOGO-GESCHWEISST / LOGO-WELDED / LOGO-SOUDE.....	198
1.23.3 GEGENSCHNEIDEN / GEGENSCHNEIDEN / GEGENSCHNEIDEN.....	200
1.23.4 DECKEL ROTORLAGER / DECKEL ROTORLAGER / DECKEL ROTORLAGER.....	202
1.23.5 DECKEL SEITENABDECKUNG / DECKEL SEITENABDECKUNG / DECKEL SEITENABDECKUNG.....	204
1.23.6 DECKEL VORNE / DECKEL VORNE / DECKEL VORNE.....	206



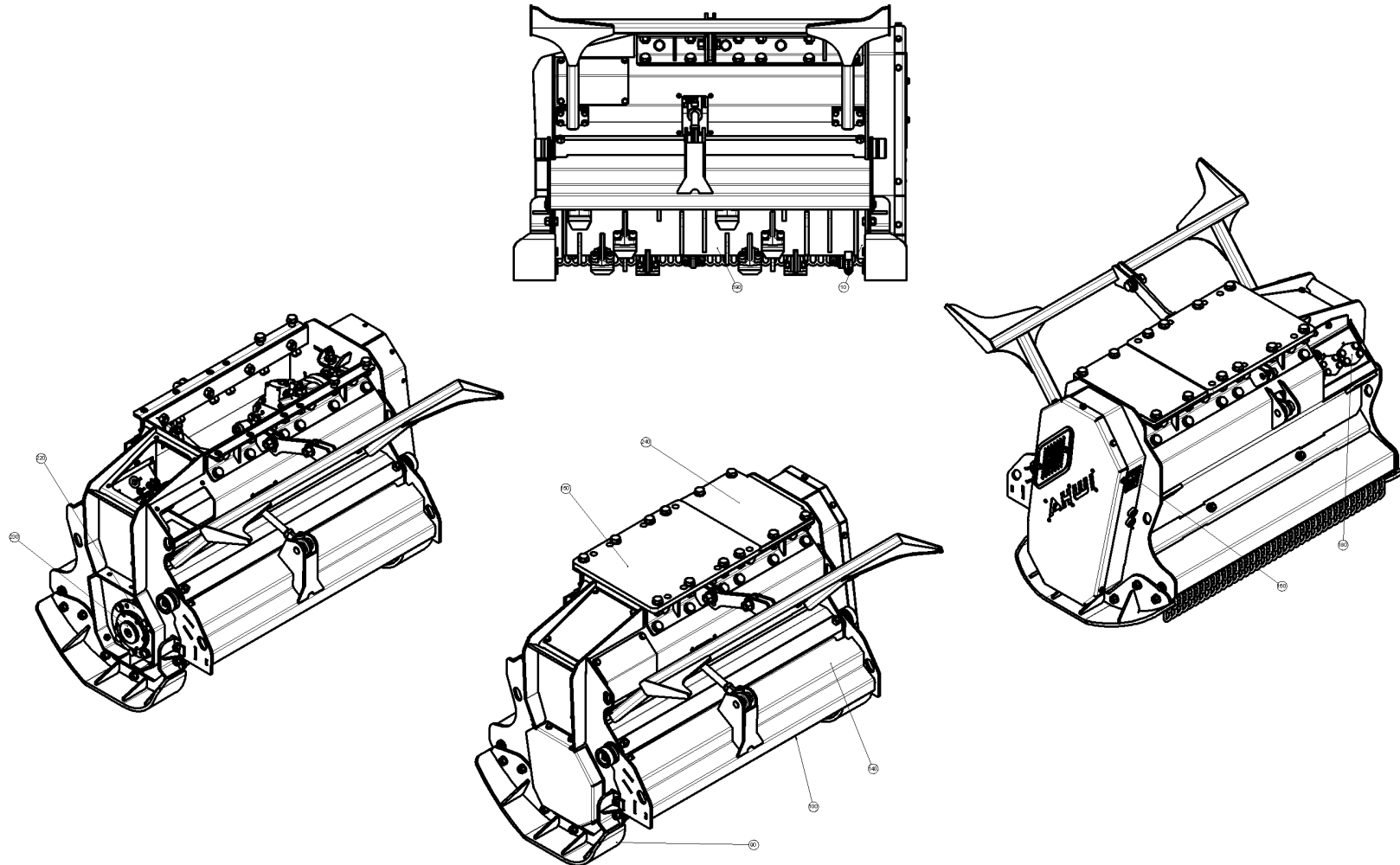







1.23.7 GEHAEUSE M450E - 1100 GESCHWEISST / GEHAEUSE M450E - 1100 GESCHWEISST / GEHAEUSE M450E - 1100 GESCHWEISST	208
1.23.7.1 MANTELBLECH / MANTELBLECH / MANTELBLECH.....	210
1.23.7.2 FRONTBLECH / FRONTBLECH / FRONTBLECH.....	212
1.23.7.3 RUECKWAND / RUECKWAND / RUECKWAND.....	214
1.23.8 ADAPTER VORNE / ADAPTER VORNE / ADAPTER VORNE	216
1.23.9 ADAPTER HINTEN / ADAPTER HINTEN / ADAPTER HINTEN.....	218
1.24 HYDRAULIK-KLAPPENSTEUERUNG ELEKTRISCH / HYDRAULIC-SHUTTER CONTROL ELECTRICAL / HYDRAULIQUE-CONTROLE CLAPET ELECTRIQUE	220
1.24.1 DECKEL / DECKEL / DECKEL.....	226
Index / Index / Index / Индекс.....	228



M450E - 1100 - M450E - 1100
M450E - 1100 - 470.00.00.00.00/02

470.00.00.00.00/02
Stücklistennummer / Piece Number / Liste de Pièces / Homep





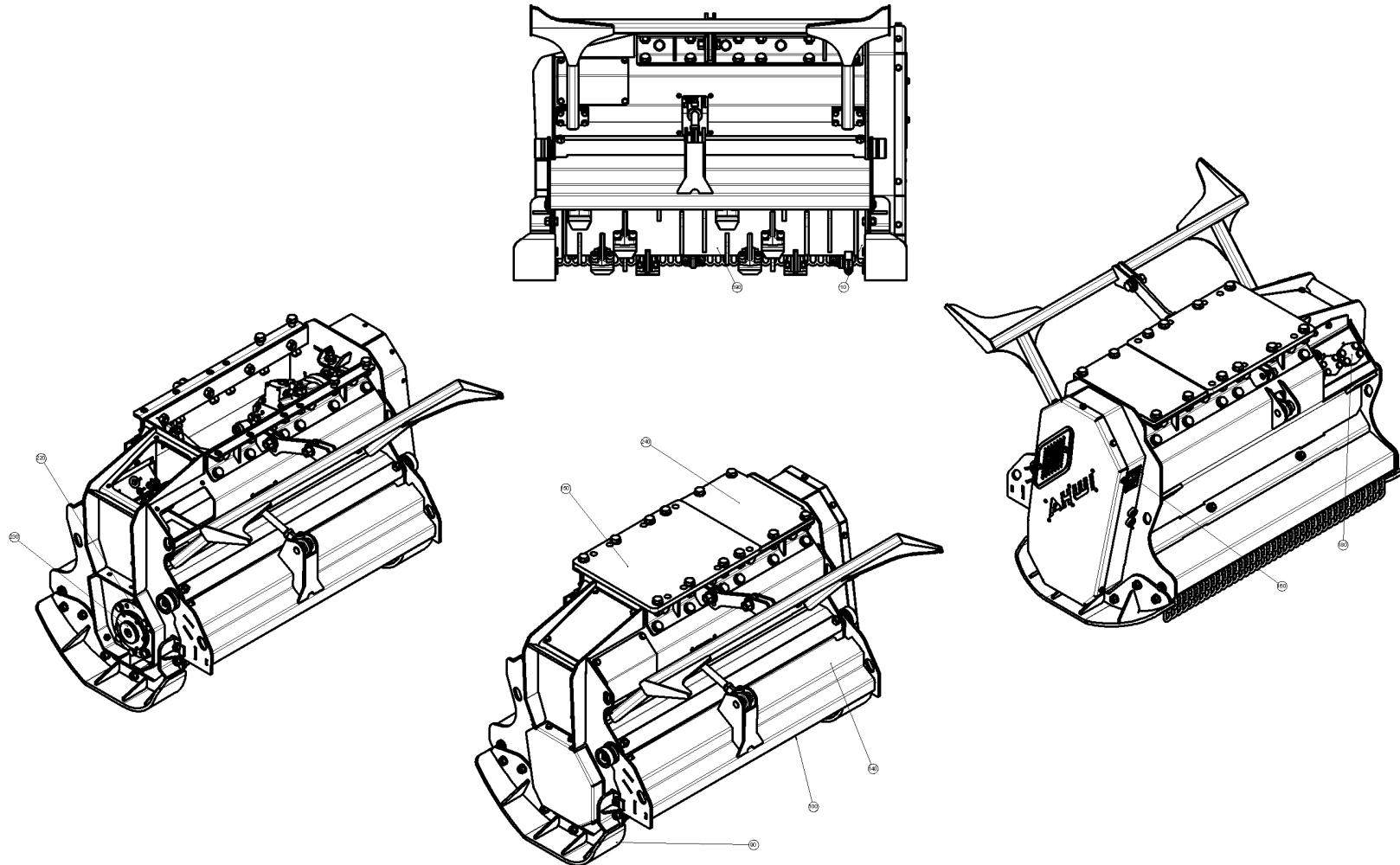





Pos.	Bestell-Nr. Stock Number Numéro de Commande Номер товара	Menge Amount Quantité Количество	Beschreibung	Description	Description	Описание
10	 460.03.00.00.00/A	1,000	<u>LABYRINTHDICHTUNG BCS ROTOR</u>	LABYRITH SEAL RING FOR BCS	LABYRITH SEAL RING FOR BCS	
20	 857.03.00.68.00/00	1,000	<u>ROTOR D450 1100 24XUPTS</u>	ROTOR D450 1100 24XUPTS	ROTOR D450 1100 24XUPTS	
30	 460.03.00.01.00/A	1,000	<u>LABYRINTHDICHTUNG UPTS ROTOR</u>	LABYRITH SEAL RING FOR UPTS	LABYRITH SEAL RING FOR UPTS	
40	 740.03.00.00.00/B	1,000	<u>ROTOR D450 1100 30XHDT02.A</u>	ROTOR D450 1100 30XHDT02.A	ROTOR D450 1100 30XHDT02.A	
50	 740.03.00.01.00/C	1,000	<u>ROTOR D450 1100 30XHDT01.A</u>	ROTOR D450 1100 30XHDT01.A	ROTOR D450 1100 30XHDT01.A	
60	 740.03.00.02.00/A	1,000	<u>ROTOR D450 1100 GEMISCHT</u>	ROTOR M450H MIXED	ROTOR M450H MIXED	
70	 740.03.00.04.00/00	1,000	<u>ROTOR D450 1100 30XHDT04.V</u>	ROTOR D450 1100 30XHDT04.V	ROTOR D450 1100 30XHDT04.V	
80	 470.03.00.02.00/00	1,000	<u>LABYRINTHDICHTUNG HDT ROTOR</u>	LABYRINTH SEAL RING FOR HDT	LABYRINTH SEAL RING FOR HDT	
90	 450.06.00.00.00/00	1,000	<u>KUFEN OHNE UNTERSCHNITT SATZ M450</u>	SKIDS	SKIDS	
100	41320830/00	1,000	<u>KLAPPE-GESCHRAUBT</u>	SHUTTER-SCREWED	CLAPET-VISSE	
110	 470.07.00.00.00/A	1,000	<u>DRUECKEVORRICHTUNG KLAPPENS. KOMPLETT</u>	PUSH-BAR ON FLAP SIDE	PUSH-BAR ON FLAP SIDE	



M450E - 1100 - M450E - 1100
M450E - 1100 - 470.00.00.00.00/02

470.00.00.00.00/02
Stücklistennummer / Piece Number / Liste de Pièces / Номер



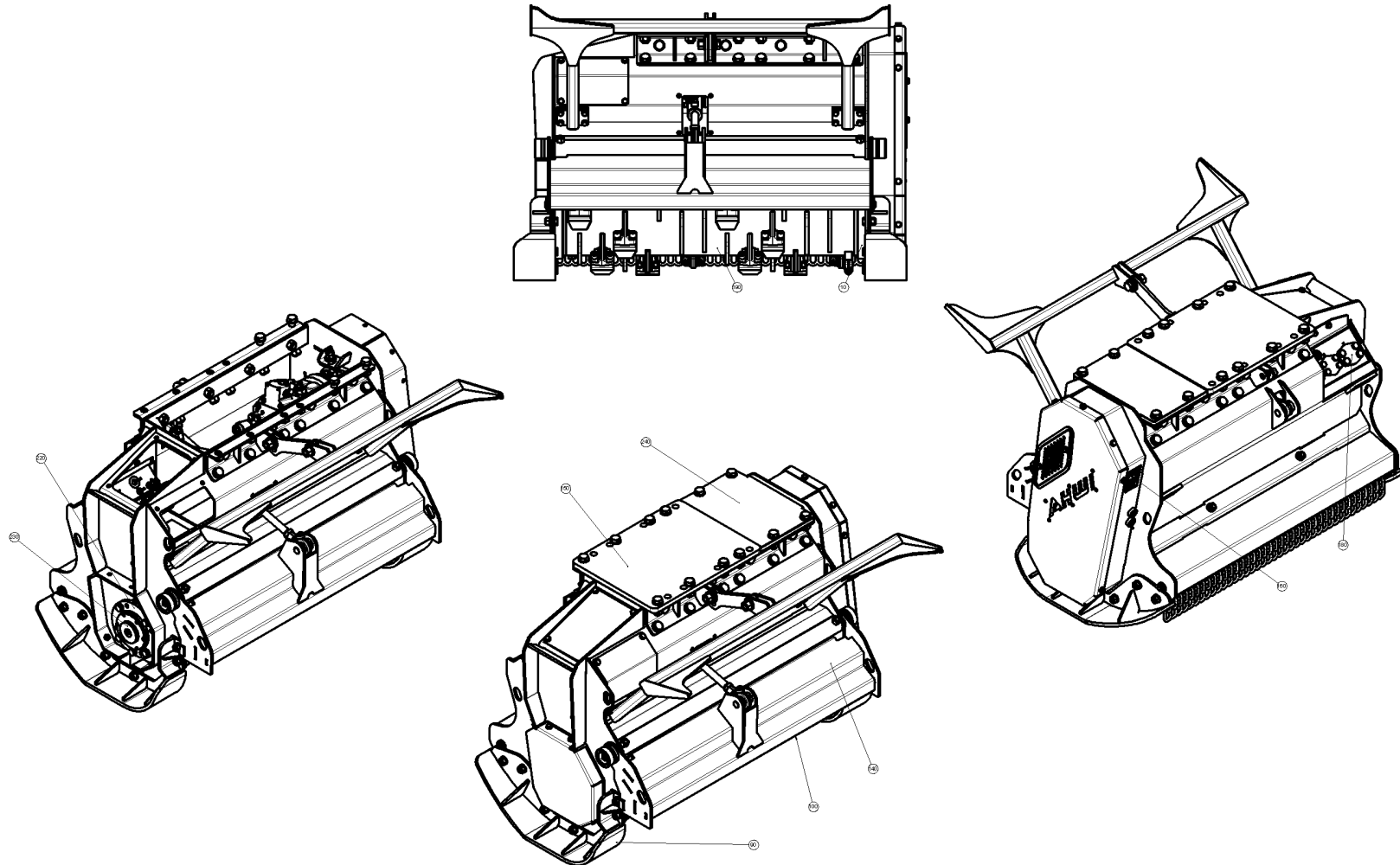

Pos.		Bestell-Nr. Stock Number Numéro de Commande Номер товара	Menge Amount Quantité Количество	Beschreibung	Description	Description	Описание
120		470.07.00.01.00/00	1,000	<u>DRUECKEVORRICHTUNG KETTENSEITIG KOMPLETT</u>	PUSH-BAR ON CHAIN GUARD SIDE	PUSH-BAR ON CHAIN GUARD SIDE	
130		470.10.03.00.00/00	1,000	<u>DECKEL WENN OHNE KLAPPE</u>	DECKEL WENN OHNE KLAPPE	DECKEL WENN OHNE KLAPPE	
140		450.11.00.00.00/03	1,000	<u>PRODUKTGRAFIK</u>	PRODUCT GRAPHICS	GRAPHIQUE DU PRODUIT	
150		470.32.01.00.00/00	1,000	<u>ADAPTERPLATTE GESCHRAUBT</u>	INTERFACE	INTERFACE	
160		551.01.00.90.00/00	1,000	<u>TYPENSCHILD + NIETEN</u>	TYPENSCHILD + NIETEN	TYPENSCHILD + NIETEN	
170		11.23.015/00	1,000	<u>ENTLUEFTUNGSKIT HYDRAULIK</u>	BREATHER KIT HYDRAULIC CIRCUIT	BREATHER KIT HYDRAULIC CIRCUIT	
180		470.15.00.00.00/04	1,000	<u>HYDRAULIKKOMPONENTEN KOMPLETT-DKOL</u>	HYDRAULIC COMPONENTS ASSY-DKOL	COMPOSANTS HYDRAULIQUES ENS-DKOL	
190		857.03.00.67.00/B	1,000	<u>ROTOR D450 1100 24XBCS</u>	ROTOR D450 1100 24XBCS	ROTOR D450 1100 24XBCS	
200		470.02.04.01.00/00	1,000	<u>RIEMENUEBERSETZUNG I=1,0</u>	RIEMENUEBERSETZUNG I=1,0	RIEMENUEBERSETZUNG I=1,0	
210		470.02.04.02.00/00	1,000	<u>RIEMENUEBERSETZUNG I=1,12</u>	RIEMENUEBERSETZUNG I=1,12	RIEMENUEBERSETZUNG I=1,12	
220		470.02.00.00.00/01	1,000	<u>ANTRIEB HYDRAULISCH</u>	HYDRAULIC DRIVE	HYDRAULIC DRIVE	



M450E - 1100 - M450E - 1100
M450E - 1100 - 470.00.00.00.00/02

470.00.00.00.00/02
Stücklistennummer / Piece Number / Liste de Pièces / Номер



Pos.	Bestell-Nr. Stock Number Numéro de Commande Номер товара	Menge Amount Quantité Количество	Beschreibung	Description	Description	Описание
230	 470.02.04.00.00/A	1,000	<u>RIEMENUEBERSETZUNG I=0,89</u>	BELT RATIO I=0,89	BELT RATIO I=0,89	
240	 470.01.00.00.00/02	1,000	<u>GEHAEUSE M450E - 1100 GESCHRAUBT</u>	GEHAEUSE M450E - 1100 GESCHRAUBT	GEHAEUSE M450E - 1100 GESCHRAUBT	
250	 470.15.00.01.00/02	1,000	<u>HYDRAULIK- KLAPPENSTEUERUNG ELEKTRISCH</u>	HYDRAULIC-SHUTTER CONTROL ELECTRICAL	HYDRAULIQUE-CONTROLE CLAPET ELECTRIQUE	

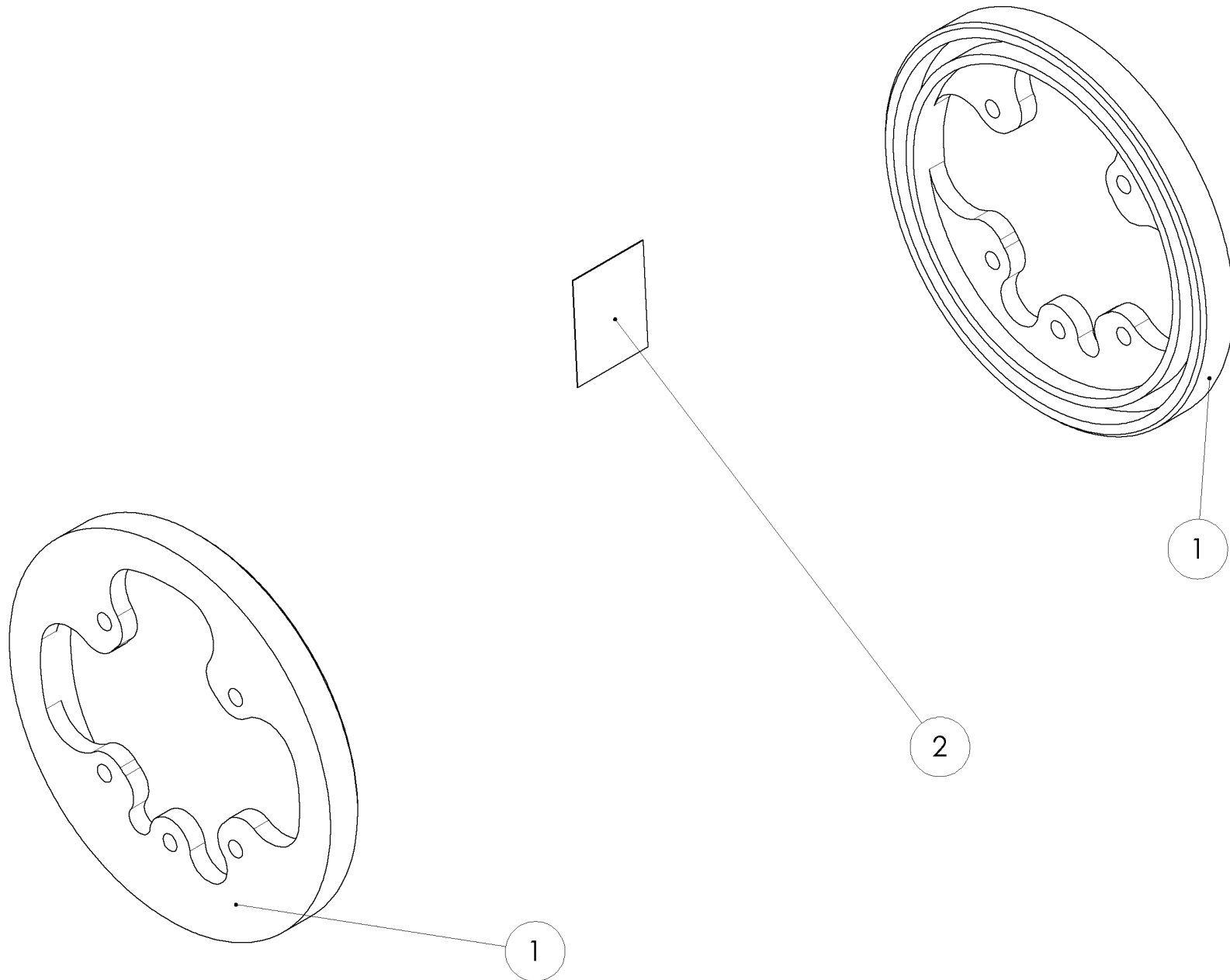

LABYRINTHDICHTUNG BCS ROTOR - LABYRITH SEAL RING FOR BCS
 LABYRITH SEAL RING FOR BCS - 460.03.00.00.00/A

460.03.00.00.00/A

Stücklistennummer / Piece Number / Liste de Pièces / Номер



Pos.	Bestell-Nr. Stock Number Numéro de Commande Номер товара	Menge Amount Quantité Количество	Beschreibung	Description	Description	Описание
10	 452.03.00.00.01/00	2,000	LABYRINTHDICHTUNG M450	LABYRINTHDICHTUNG M450	LABYRINTHDICHTUNG M450	
20	 85.01.133/02	1,000	AUFKLEBER- ANZIEHDREHMOMENT BCS	STICKER-TIGHTENING TORQUE BCS	AUTOCOLLANT-COUPLE DE SERRAGE BCS	

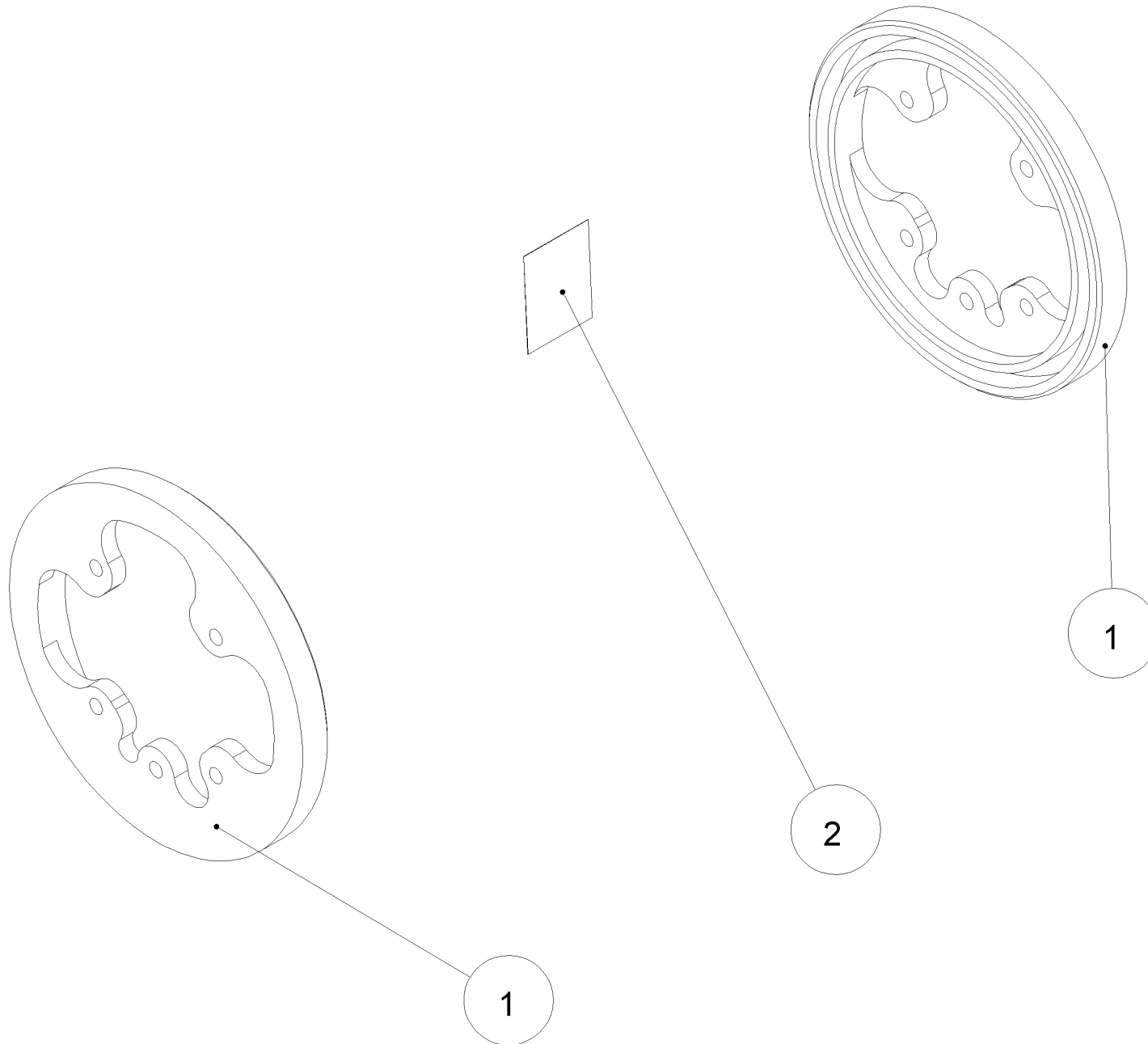

LABYRINTHDICHTUNG BCS ROTOR - LABYRITH SEAL RING FOR BCS
 LABYRITH SEAL RING FOR BCS - 460.03.00.00.00/A

460.03.00.00.00/A

Stücklistennummer / Piece Number / Liste de Pièces / Номер





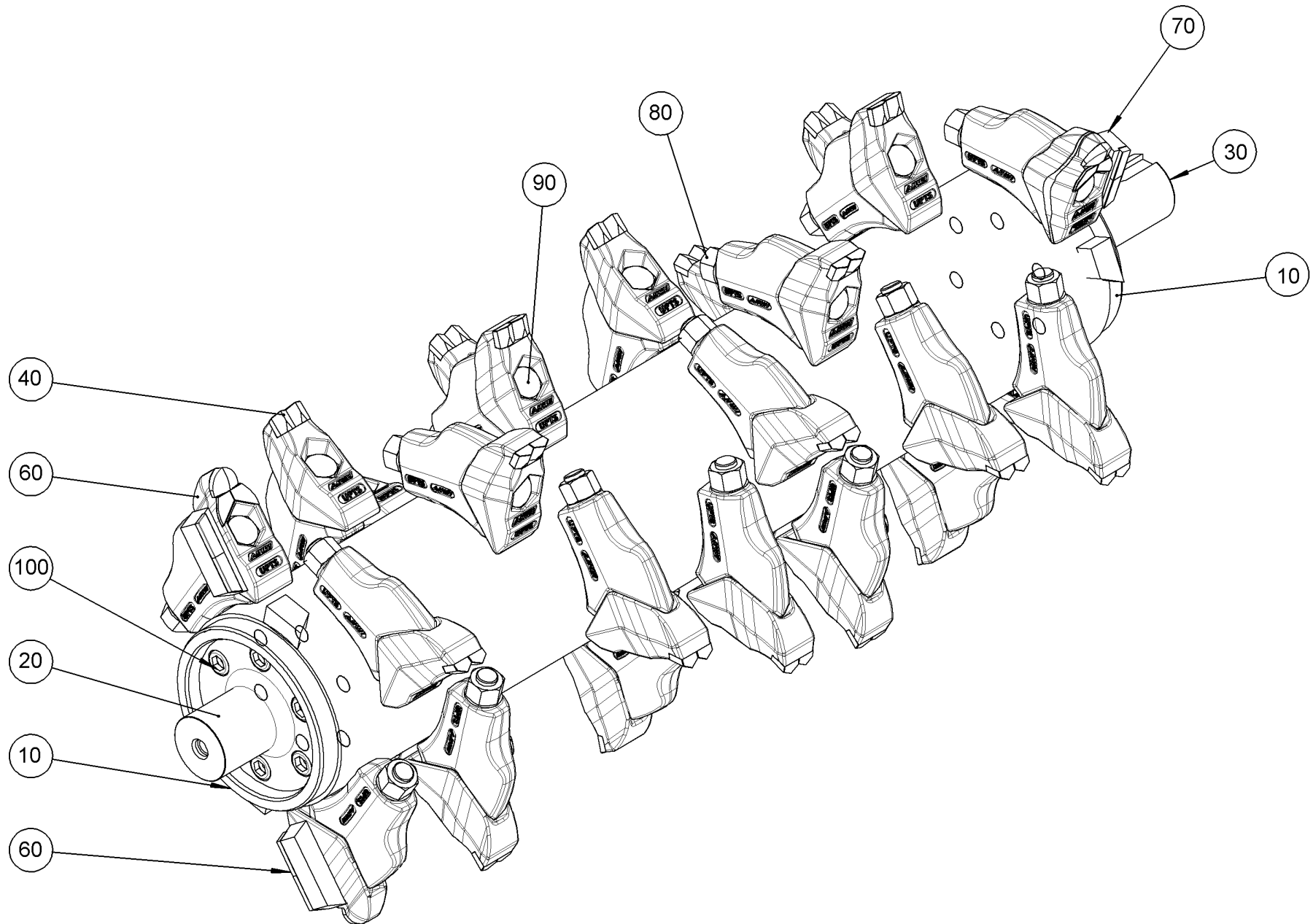







Pos.	Bestell-Nr. Stock Number Numéro de Commande Номер товара	Menge Amount Quantité Количество	Beschreibung	Description	Description	Описание
10	 452.03.00.00.01/00	2,000	LABYRINTHDICHTUNG M450	LABYRINTHDICHTUNG M450	LABYRINTHDICHTUNG M450	
20	 85.01.133/02	1,000	AUFKLEBER- ANZIEHDREHMOMENT BCS	STICKER-TIGHTENING TORQUE BCS	AUTOCOLLANT-COUPLE DE SERRAGE BCS	





ROTOR D450 1100 24XUPTS - ROTOR D450 1100 24XUPTS
 ROTOR D450 1100 24XUPTS - 857.03.00.68.00/00

857.03.00.68.00/00
 Stücklistennummer / Piece Number / Liste de Pièces / Homep

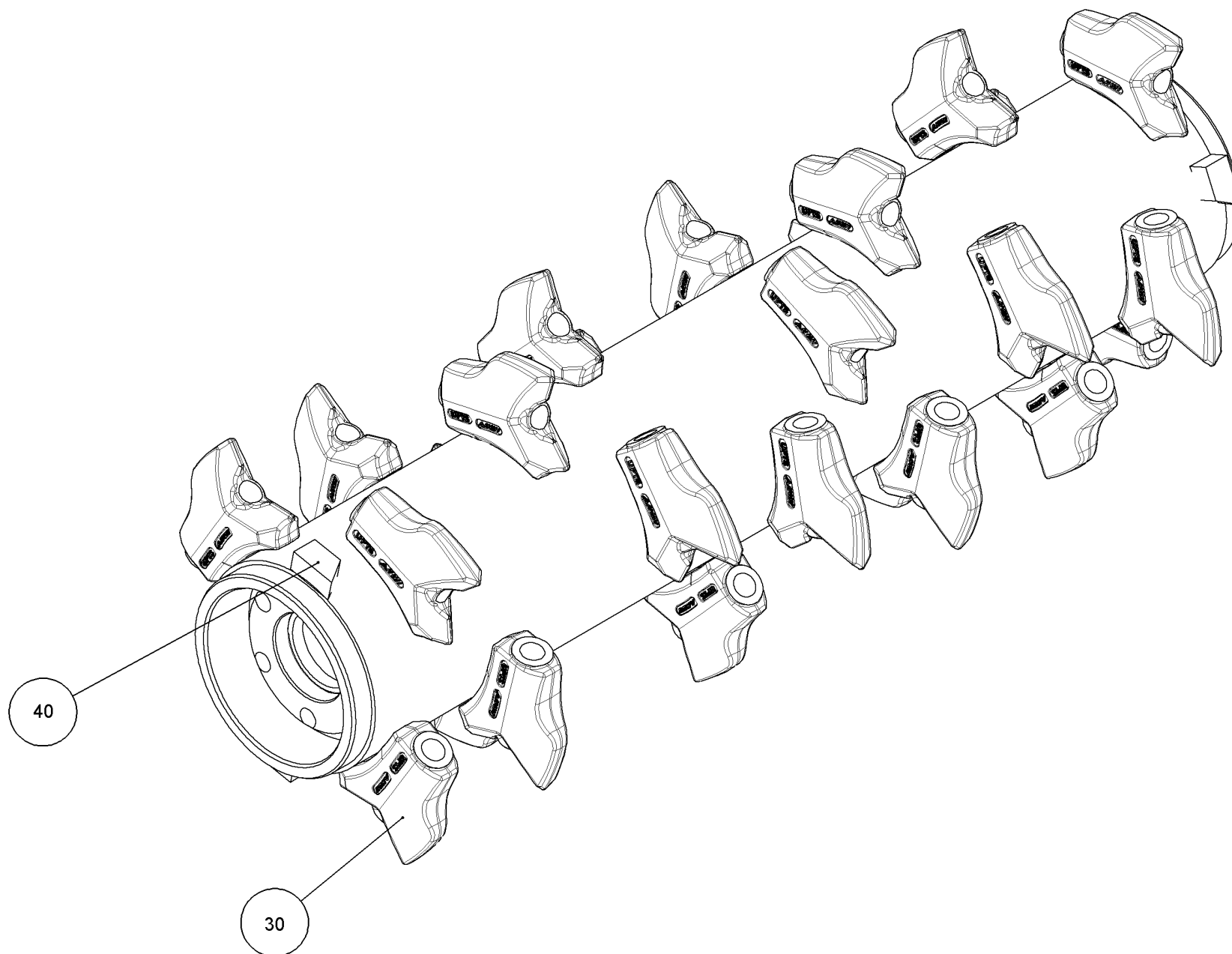

Pos.		Bestell-Nr. Stock Number Numéro de Commande Номер товара	Menge Amount Quantité Количество	Beschreibung	Description	Description	Описание
10		857.03.01.68.00/00	1,000	<u>ROTORGRUNDKOERPER MIT HALTER</u>	ROTORGRUNDKOERPER MIT HALTER	ROTORGRUNDKOERPER MIT HALTER	
20		740.03.00.00.01/01	1,000	<u>ROTORSTUMMEL KURZ</u>	ROTOR SHOFT	ROTOR SHOFT	
30		754.03.00.00.01/I	1,000	ROTORWELLENSTUMMEL D65	ROTOR SHAFT STUB FM500	ROTOR SHAFT STUB FM500	
40		46.UPTS02/A	24,0-00	WERKZEUG UPTS02	TOOL UPTS02	OUTIL UPTS02	
50		46.UPTS04/A	24,0-00	WERKZEUG UPTS04	TOOL UPTS04	OUTIL UPTS04	
60		46.UPTS05/B	2,000	<u>WERKZEUG UPTS05</u>	TOOL UPTS05	OUTIL UPTS05	
70		46.UPTS06/B	2,000	<u>WERKZEUG UPTS06</u>	TOOL UPTS06	OUTIL UPTS06	
80		03.03.20.S.C	28,0-00	SKT-MUTTER M20X1,5 10, SELBSTSICH.	NUT M20X1,5-10 DIN 980 SE-LOCK	NUT M20X1,5-10 DIN 980 SE-LOCK	
90		01.80.20.S.155.C	28,0-00	SKT-SCHRAUBE M20X1,5X155	HEX SCREW M20X1,5X155-10.9	HEX SCREW M20X1,5X155-10.9	
100		01.21.16080.C	12,0-00	ZYLINDERSCHRAUBE M16X80 10.9 VERGUETET	CYL. HEAD SCREW M16X80 DIN6912	CYL. HEAD SCREW M16X80 DIN6912	



Pos.		Bestell-Nr. Stock Number Numéro de Commande Номер товара	Menge Amount Quantité Количество	Beschreibung	Description	Description	Описание
30		46.UPTS01/03	28,0-00	WERKZEUG-HALTER UPTS01	TOOL-SUPPORT UPTS01	OUTIL-SUPPORT UPTS01	
40		857.03.03.28.01/00	4,000	VERSCHLEISSSCHUTZ FUER SCHWEISSNAHT	WEAR PROTECTION	WEAR PROTECTION	

ROTORSTUMMEL KURZ - ROTOR SHOFT
ROTOR SHOFT - 740.03.00.00.01/01

740.03.00.00.01/01
Stücklistennummer / Piece Number / Liste de Pièces / Homep



ROTORSTUMMEL KURZ - ROTOR SHOFT
ROTOR SHOFT - 740.03.00.00.01/01

740.03.00.00.01/01
Stücklistennummer / Piece Number / Liste de Pièces / Номер



Pos.	Bestell-Nr. Stock Number Numéro de Commande Номер товара	Menge Amount Quantité Количество	Beschreibung	Description	Description	Описание
------	---	---	--------------	-------------	-------------	----------

1	 740.03.00.00.01/01	1,000	ROTORWELLENSTUMMEL D65	ROTOR SHAFT STUB FM500	ROTOR SHAFT STUB FM500	
---	--	-------	------------------------	------------------------	------------------------	--



WERKZEUG UPTS05 - TOOL UPTS05
OUTIL UPTS05 - 46.UPTS05/B

46.UPTS05/B
Stücklistennummer / Piece Number / Liste de Pièces / Номер



Pos.	Bestell-Nr. Stock Number Numéro de Commande Номер товара	Menge Amount Quantité Количество	Beschreibung	Description	Description	Описание
------	---	---	--------------	-------------	-------------	----------

10	 46.UPTS04/A	1,000	WERKZEUG UPTS04	TOOL UPTS04	OUTIL UPTS04	
----	---	-------	-----------------	-------------	--------------	--

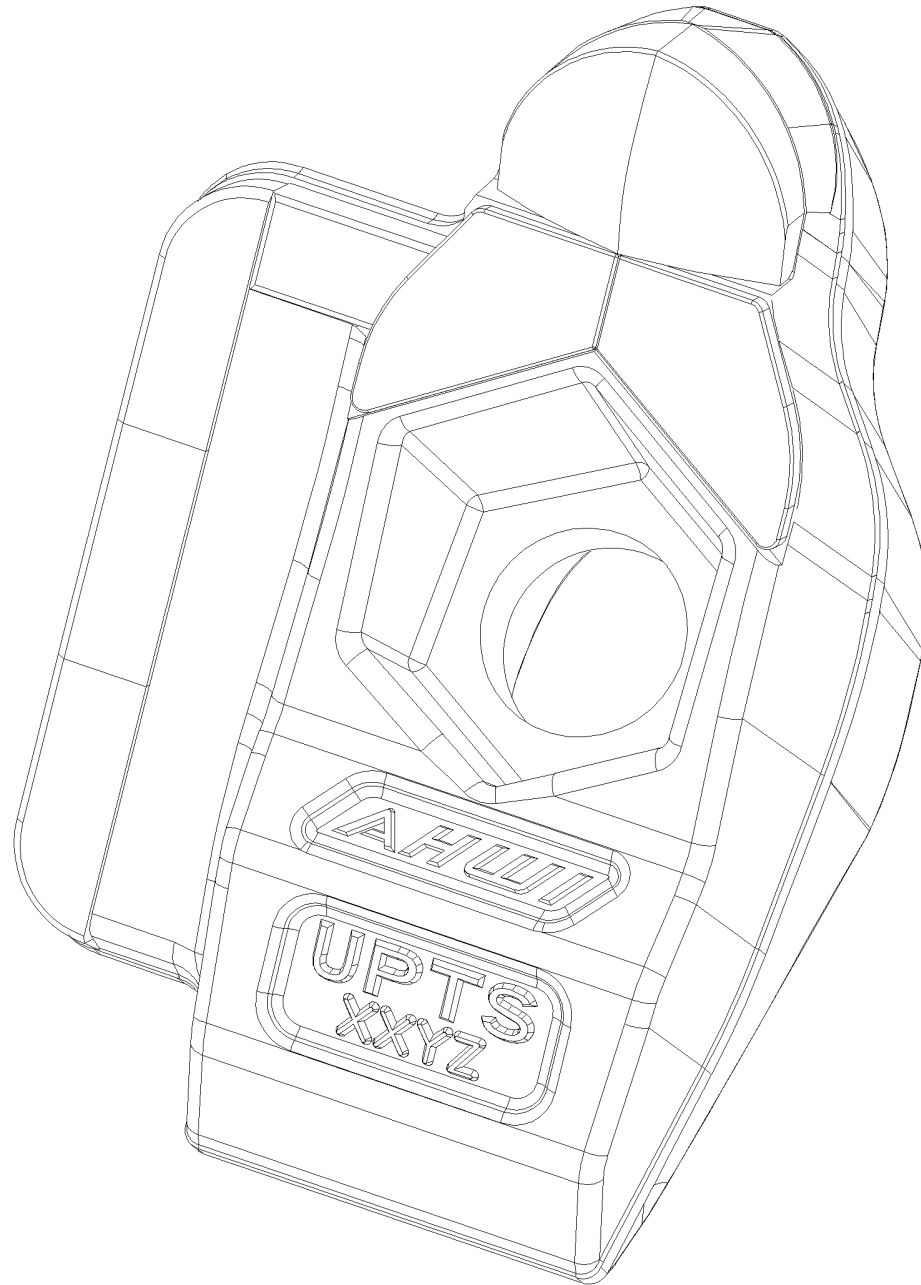

WERKZEUG UPTS05 - TOOL UPTS05
OUTIL UPTS05 - 46.UPTS05/B

46.UPTS05/B
Stücklistennummer / Piece Number / Liste de Pièces / Номер



Pos.	Bestell-Nr. Stock Number Numéro de Commande Номер товара	Menge Amount Quantité Количество	Beschreibung	Description	Description	Описание
------	---	---	--------------	-------------	-------------	----------

10	 46.UPTS04/A	1,000	WERKZEUG UPTS04	TOOL UPTS04	OUTIL UPTS04	
----	---	-------	-----------------	-------------	--------------	--

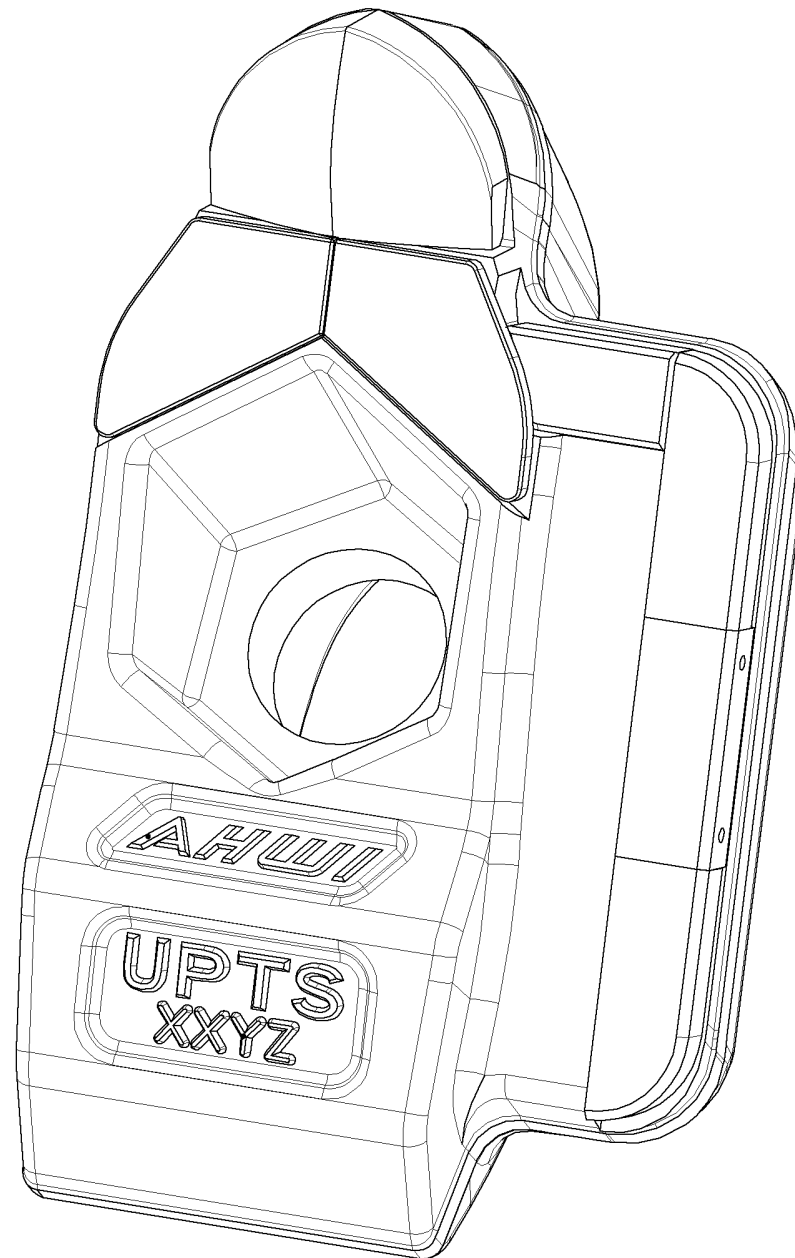

WERKZEUG UPTS06 - TOOL UPTS06
OUTIL UPTS06 - 46.UPTS06/B

46.UPTS06/B
Stücklistennummer / Piece Number / Liste de Pièces / Номер



Pos.	Bestell-Nr. Stock Number Numéro de Commande Номер товара	Menge Amount Quantité Количество	Beschreibung	Description	Description	Описание
------	---	---	--------------	-------------	-------------	----------

10	 46.UPTS04/A	1,000	WERKZEUG UPTS04	TOOL UPTS04	OUTIL UPTS04	
----	---	-------	-----------------	-------------	--------------	--

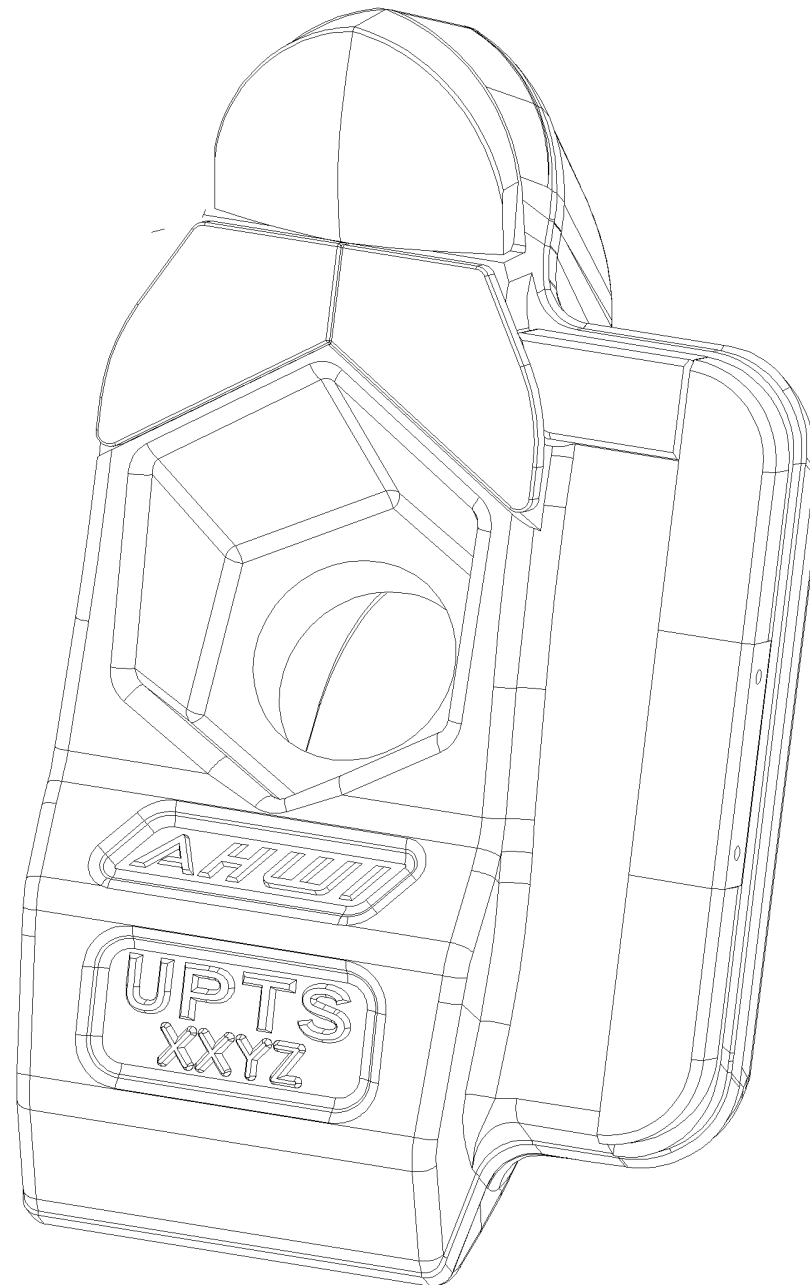

WERKZEUG UPTS06 - TOOL UPTS06
OUTIL UPTS06 - 46.UPTS06/B

46.UPTS06/B
Stücklistennummer / Piece Number / Liste de Pièces / Номер



Pos.	Bestell-Nr. Stock Number Numéro de Commande Номер товара	Menge Amount Quantité Количество	Beschreibung	Description	Description	Описание
------	---	---	--------------	-------------	-------------	----------

10	 46.UPTS04/A	1,000	WERKZEUG UPTS04	TOOL UPTS04	OUTIL UPTS04	
----	---	-------	-----------------	-------------	--------------	--

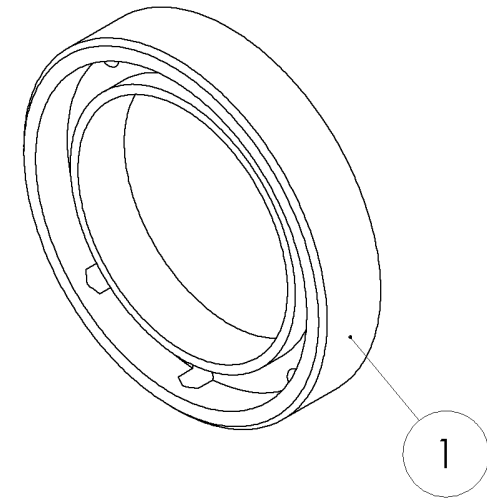
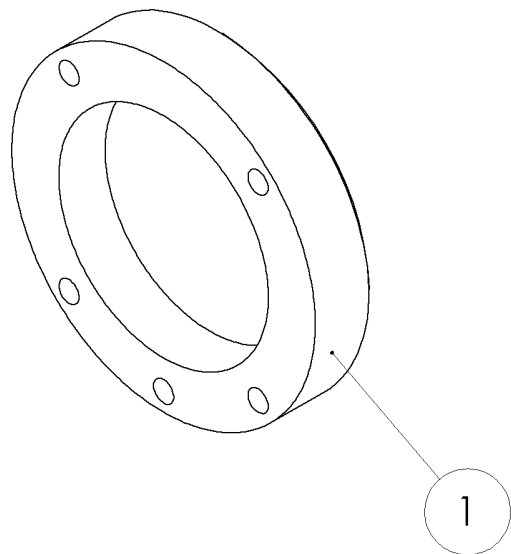



LABYRINTHDICHTUNG UPTS ROTOR - LABYRITH SEAL RING FOR UPTS
 LABYRITH SEAL RING FOR UPTS - 460.03.00.01.00/A

460.03.00.01.00/A

Stücklistennummer / Piece Number / Liste de Pièces / Номер



Pos.	Bestell-Nr. Stock Number Numéro de Commande Номер товара	Menge Amount Quantité Количество	Beschreibung	Description	Description	Описание
10	 450.03.00.00.01/A	2,000	LABYRINTHDICHTUNG M450	LABYRINTHDICHTUNG M450	LABYRINTHDICHTUNG M450	
20	 85.01.132/02	1,000	AUFKLEBER- ANZIEHDREHMOMENT UPTS	STICKER-TIGHTENING TORQUE UPTS	AUTOCOLLANT-COUPLE DE SERRAGE UPTS	

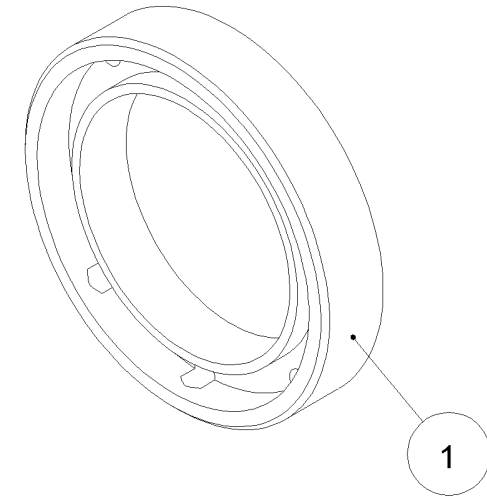
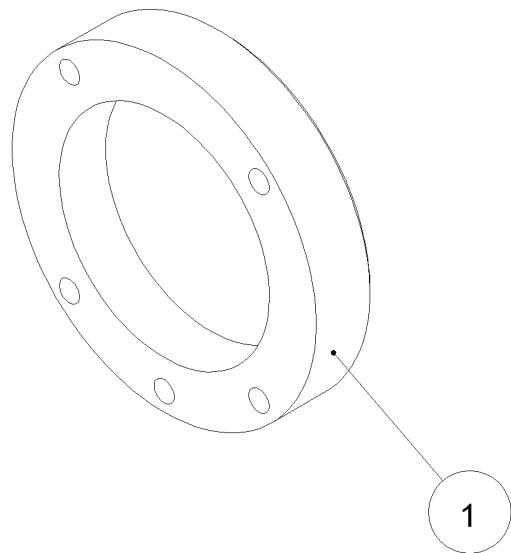



LABYRINTHDICHTUNG UPTS ROTOR - LABYRITH SEAL RING FOR UPTS
 LABYRITH SEAL RING FOR UPTS - 460.03.00.01.00/A

460.03.00.01.00/A

Stücklistennummer / Piece Number / Liste de Pièces / Номер





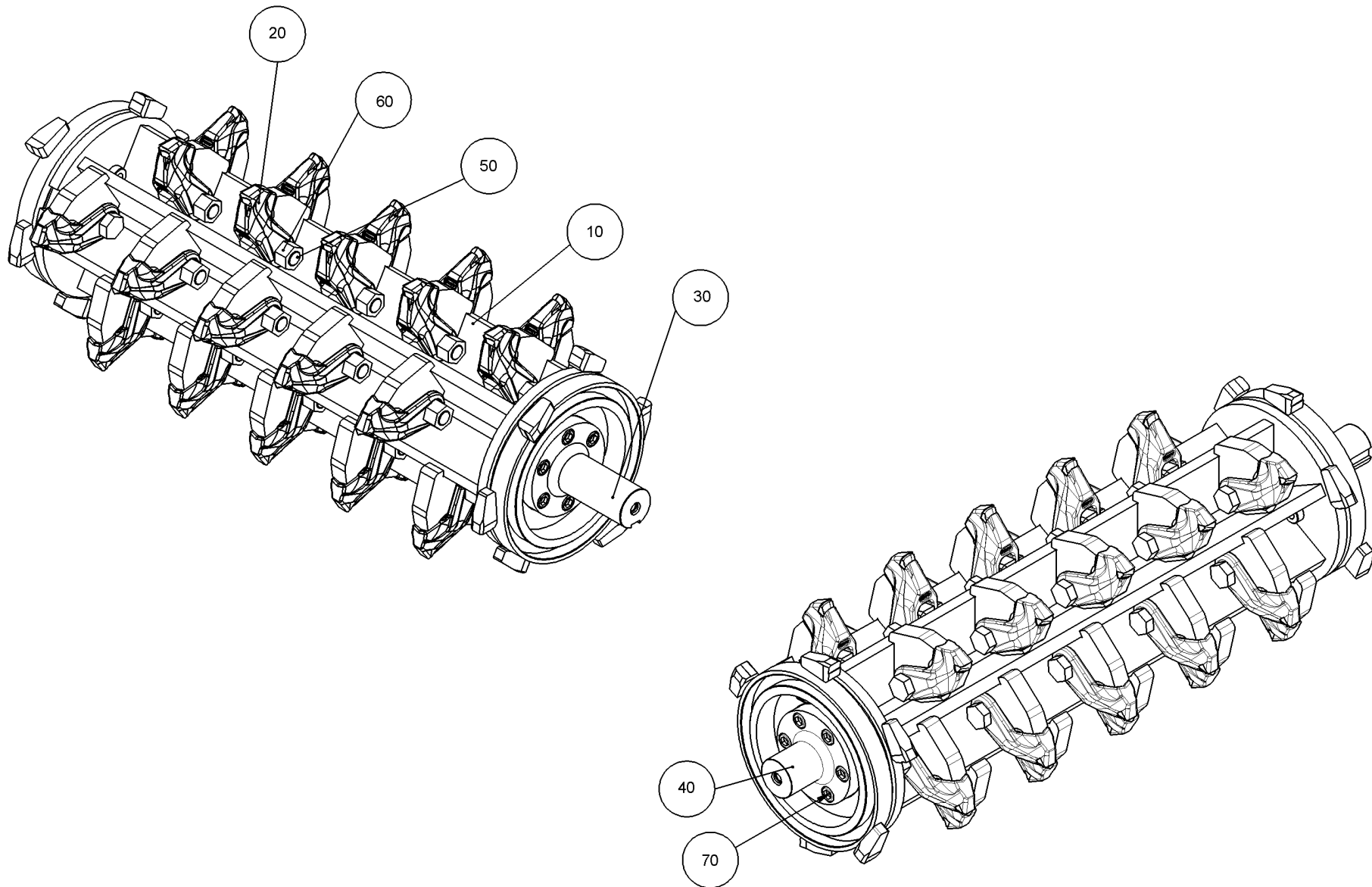





Pos.	Bestell-Nr. Stock Number Numéro de Commande Номер товара	Menge Amount Quantité Количество	Beschreibung	Description	Description	Описание
10	 450.03.00.00.01/A	2,000	LABYRINTHDICHTUNG M450	LABYRINTHDICHTUNG M450	LABYRINTHDICHTUNG M450	
20	 85.01.132/02	1,000	AUFKLEBER- ANZIEHDREHMOMENT UPTS	STICKER-TIGHTENING TORQUE UPTS	AUTOCOLLANT-COUPLE DE SERRAGE UPTS	



ROTOR D450 1100 30XHDT02.A - ROTOR D450 1100 30XHDT02.A
 ROTOR D450 1100 30XHDT02.A - 740.03.00.00/B

740.03.00.00/B
 Stücklistennummer / Piece Number / Liste de Pièces / Номер





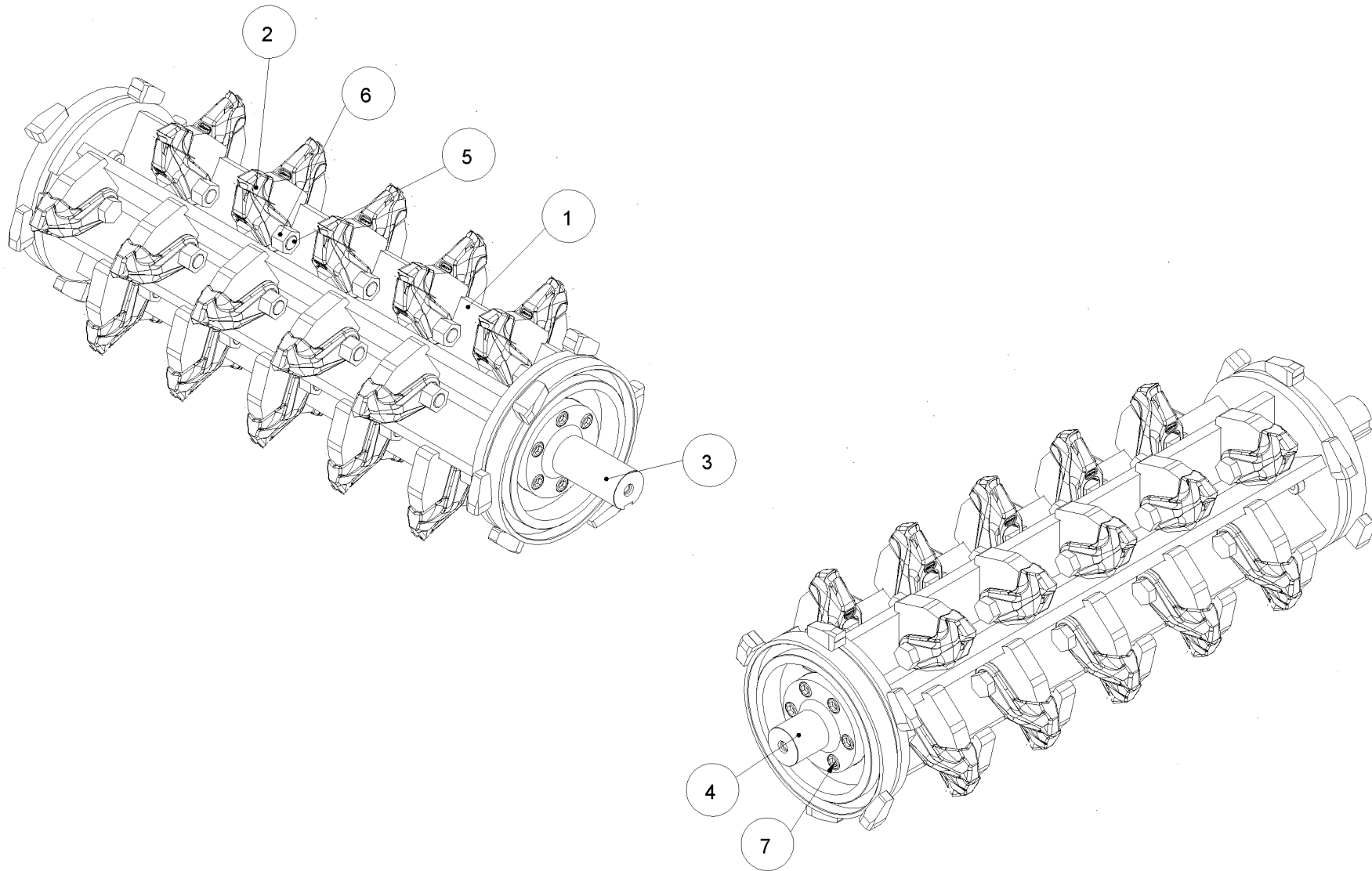





Pos.		Bestell-Nr. Stock Number Numéro de Commande Номер товара	Menge Amount Quantité Количество	Beschreibung	Description	Description	Описание
10		740.03.01.00.00/E	1,000	ROTOR M450H GESCHWEISST	ROTOR M450H WELDED	ROTOR M450H WELDED	
20		46.HDT02.A/B	30,0- 00	WERKZEUG HDT02.A	TOOL HDT02.A	OUTIL HDT02.A	
30		754.03.00.00.01/I	1,000	ROTORWELLENSTUMMEL D65	ROTOR SHAFT STUB FM500	ROTOR SHAFT STUB FM500	
40		01.80.24.T.085.C	30,0- 00	SKT-SCHRAUBE M24X85X2	HEX. SCREW M24X2X85-10.9DIN960	HEX. SCREW M24X2X85-10.9DIN960	
50		03.03.24.T.C	30,0- 00	SKT-MUTTER M24X2 10, SELBSTSICH.	NUT M24X2 DIN980 SE.-LOCK.	NUT M24X2 DIN980 SE.-LOCK.	
60		01.21.16050.C	12,0- 00	ZYLINDERSCHRAUBE M16X50	SCREW M16X50 DIN6912	SCREW M16X50 DIN6912	
70		740.03.00.00.01/01	1,000	ROTORSTUMMEL KURZ	ROTOR SHOFT	ROTOR SHOFT	



ROTOR D450 1100 30XHDT02.A - ROTOR D450 1100 30XHDT02.A
 ROTOR D450 1100 30XHDT02.A - 740.03.00.00/B

740.03.00.00/B
 Stücklistennummer / Piece Number / Liste de Pièces / Homep



Pos.		Bestell-Nr. Stock Number Numéro de Commande Номер товара	Menge Amount Quantité Количество	Beschreibung	Description	Description	Описание
10		740.03.01.00.00/E	1,000	ROTOR M450H GESCHWEISST	ROTOR M450H WELDED	ROTOR M450H WELDED	
20		46.HDT02.A/B	30,0- 00	WERKZEUG HDT02.A	TOOL HDT02.A	OUTIL HDT02.A	
30		754.03.00.00.01/I	1,000	ROTORWELLENSTUMMEL D65	ROTOR SHAFT STUB FM500	ROTOR SHAFT STUB FM500	
40		01.80.24.T.085.C	30,0- 00	SKT-SCHRAUBE M24X85X2	HEX. SCREW M24X2X85-10.9DIN960	HEX. SCREW M24X2X85-10.9DIN960	
50		03.03.24.T.C	30,0- 00	SKT-MUTTER M24X2 10, SELBSTSICH.	NUT M24X2 DIN980 SE.-LOCK.	NUT M24X2 DIN980 SE.-LOCK.	
60		01.21.16050.C	12,0- 00	ZYLINDERSCHRAUBE M16X50	SCREW M16X50 DIN6912	SCREW M16X50 DIN6912	
70		740.03.00.00.01/01	1,000	ROTORSTUMMEL KURZ	ROTOR SHOFT	ROTOR SHOFT	

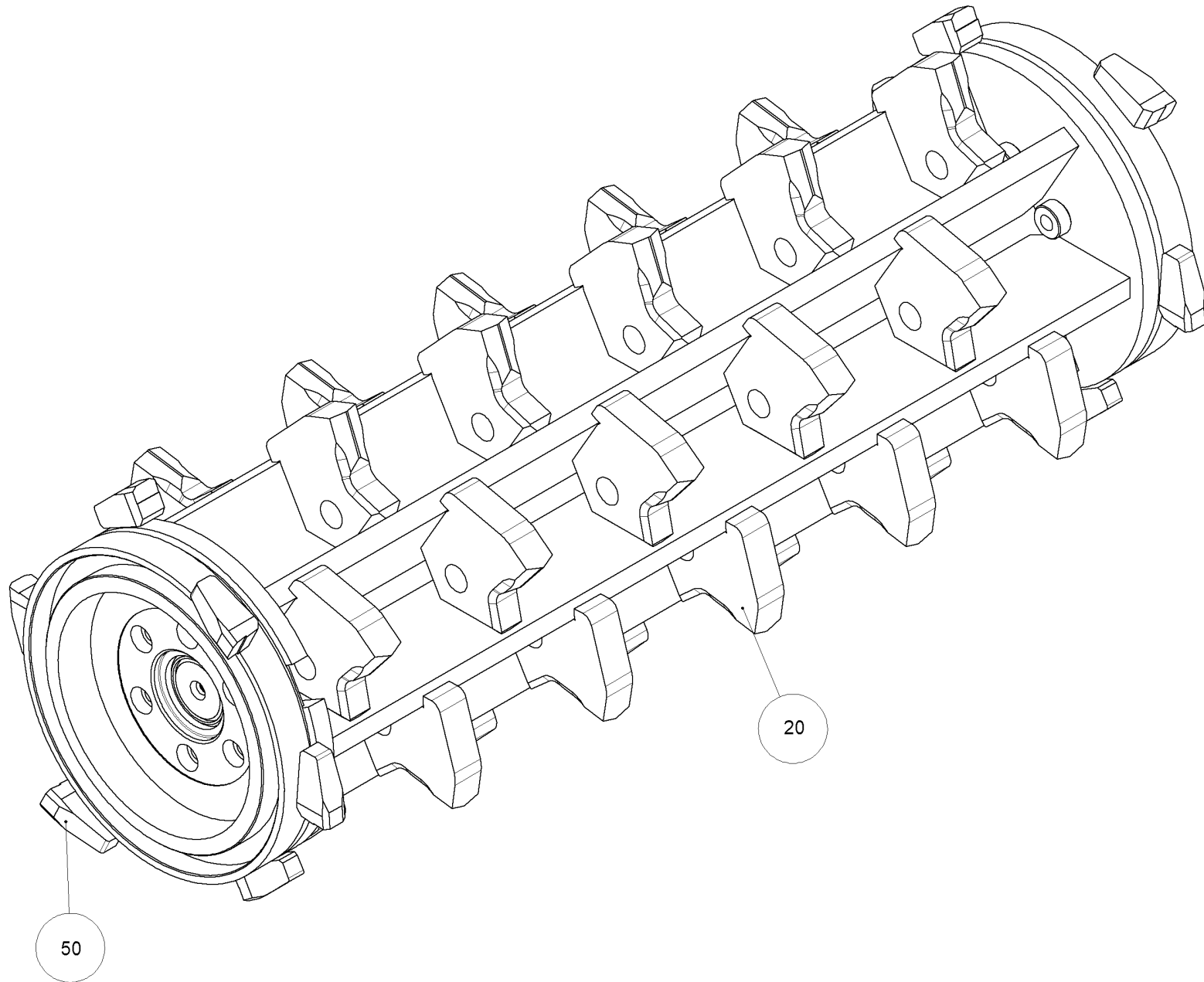

ROTOR M450H GESCHWEISST - ROTOR M450H WELDED
 ROTOR M450H WELDED - 740.03.01.00.00/E

740.03.01.00.00/E
 Stücklistennummer / Piece Number / Liste de Pièces / Номер



Pos.	Bestell-Nr. Stock Number Numéro de Commande Номер товара	Menge Amount Quantité Количество	Beschreibung	Description	Description	Описание
20	 740.03.01.00.01/F	30,0-00	MEISSELHALTERUNG HDT ROTOR D450	MEISSELHALTERUNG HDT ROTOR D450	MEISSELHALTERUNG HDT ROTOR D450	
50	 46.BFZ25.G/00	12,0-00	WERKZEUG BFZ25.G	TOOL BFZ25.G	OUTIL BFZ25.G	

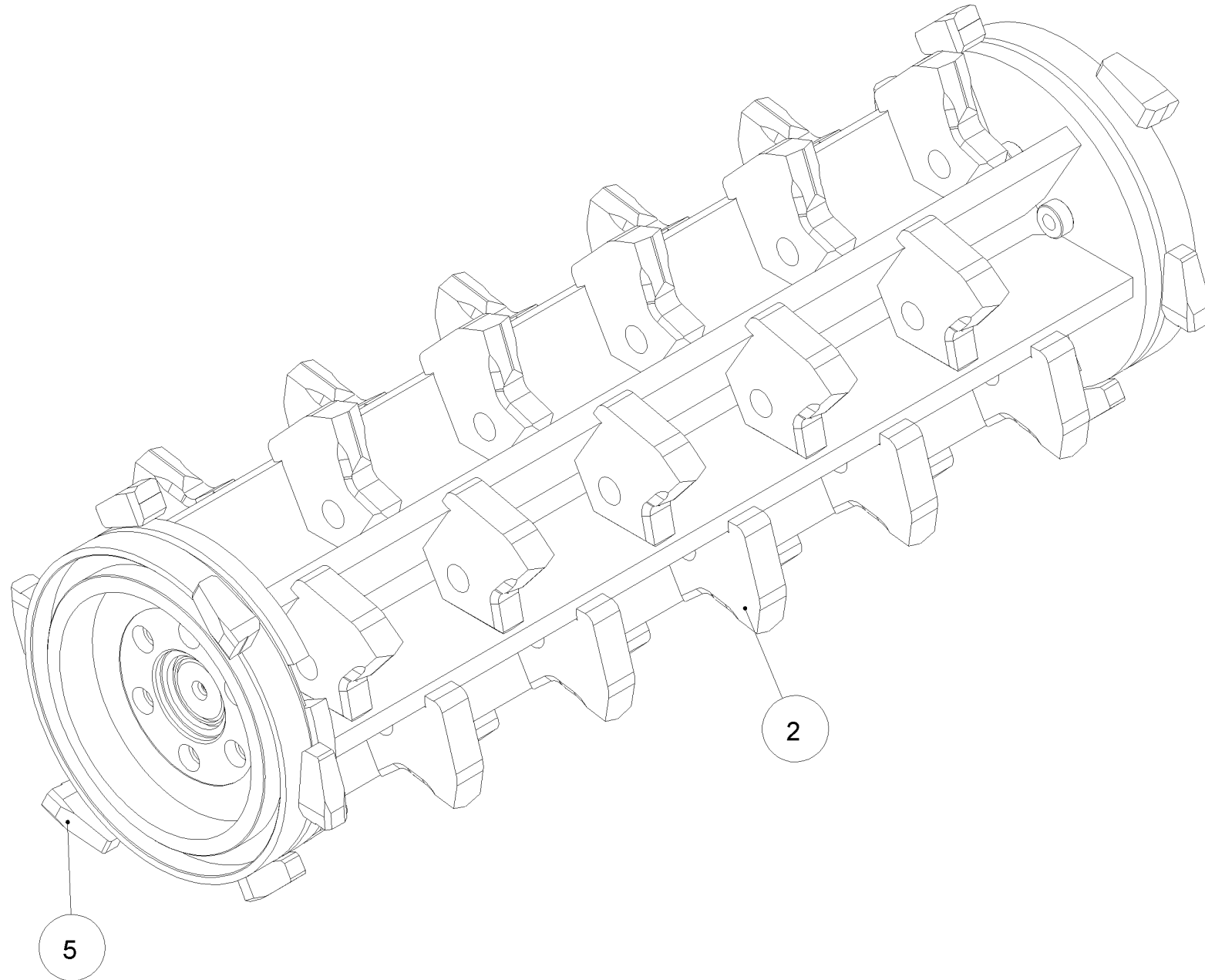

ROTOR M450H GESCHWEISST - ROTOR M450H WELDED
 ROTOR M450H WELDED - 740.03.01.00.00/E

740.03.01.00.00/E
 Stücklistennummer / Piece Number / Liste de Pièces / Номер



Pos.	Bestell-Nr. Stock Number Numéro de Commande Номер товара	Menge Amount Quantité Количество	Beschreibung	Description	Description	Описание
20	 740.03.01.00.01/F	30,0-00	MEISSELHALTERUNG HDT ROTOR D450	MEISSELHALTERUNG HDT ROTOR D450	MEISSELHALTERUNG HDT ROTOR D450	
50	 46.BFZ25.G/00	12,0-00	WERKZEUG BFZ25.G	TOOL BFZ25.G	OUTIL BFZ25.G	

ROTORSTUMMEL KURZ - ROTOR SHOFT
ROTOR SHOFT - 740.03.00.00.01/01

740.03.00.00.01/01
Stücklistennummer / Piece Number / Liste de Pièces / Homep



ROTORSTUMMEL KURZ - ROTOR SHOFT
ROTOR SHOFT - 740.03.00.00.01/01

740.03.00.00.01/01
Stücklistennummer / Piece Number / Liste de Pièces / Номер



Pos.	Bestell-Nr. Stock Number Numéro de Commande Номер товара	Menge Amount Quantité Количество	Beschreibung	Description	Description	Описание
------	---	---	--------------	-------------	-------------	----------



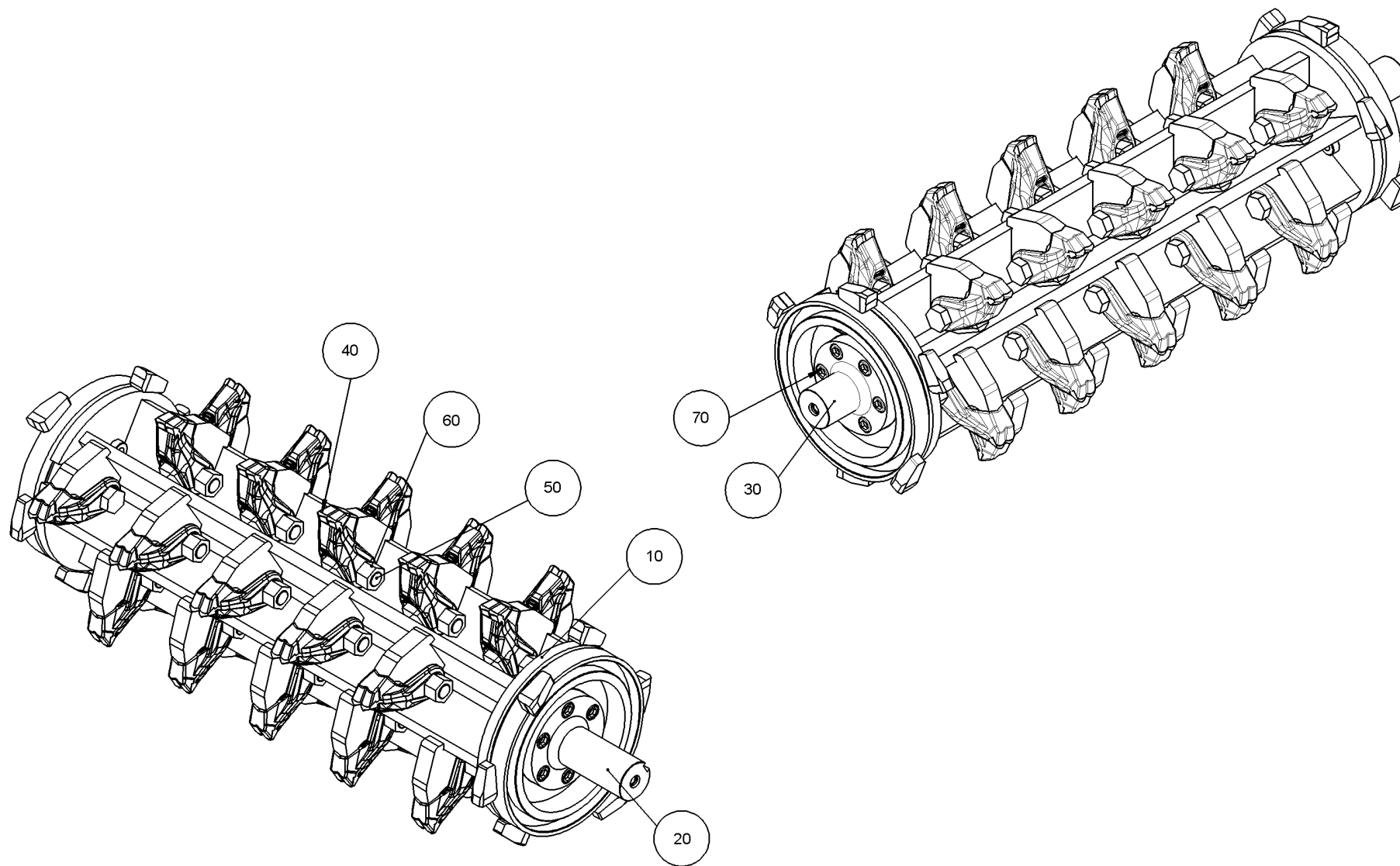



1	 740.03.00.00.01/01	1,000	ROTORWELLENSTUMMEL D65	ROTOR SHAFT STUB FM500	ROTOR SHAFT STUB FM500	
---	--	-------	------------------------	------------------------	------------------------	--



ROTOR D450 1100 30XHDT01.A - ROTOR D450 1100 30XHDT01.A
 ROTOR D450 1100 30XHDT01.A - 740.03.00.01.00/C

740.03.00.01.00/C
 Stücklistennummer / Piece Number / Liste de Pièces / Номер



Pos.		Bestell-Nr. Stock Number Numéro de Commande Номер товара	Menge Amount Quantité Количество	Beschreibung	Description	Description	Описание
10		740.03.01.00.00/E	1,000	ROTOR M450H GESCHWEISST	ROTOR M450H WELDED	ROTOR M450H WELDED	
20		754.03.00.00.01/I	1,000	ROTORWELLENSTUMMEL D65	ROTOR SHAFT STUB FM500	ROTOR SHAFT STUB FM500	
30		740.03.00.00.01/01	1,000	ROTORSTUMMEL KURZ	ROTOR SHOFT	ROTOR SHOFT	
40		46.HDT01.A/B	30,0- 00	WERKZEUG HDT01.A	TOOL HDT01.A	OUTIL HDT01.A	
50		01.80.24.T.085.C	30,0- 00	SKT-SCHRAUBE M24X85X2	HEX. SCREW M24X2X85-10.9DIN960	HEX. SCREW M24X2X85-10.9DIN960	
60		03.03.24.T.C	30,0- 00	SKT-MUTTER M24X2 10, SELBSTSICH.	NUT M24X2 DIN980 SE.-LOCK.	NUT M24X2 DIN980 SE.-LOCK.	
70		01.21.16050.C	12,0- 00	ZYLINDERSCHRAUBE M16X50	SCREW M16X50 DIN6912	SCREW M16X50 DIN6912	

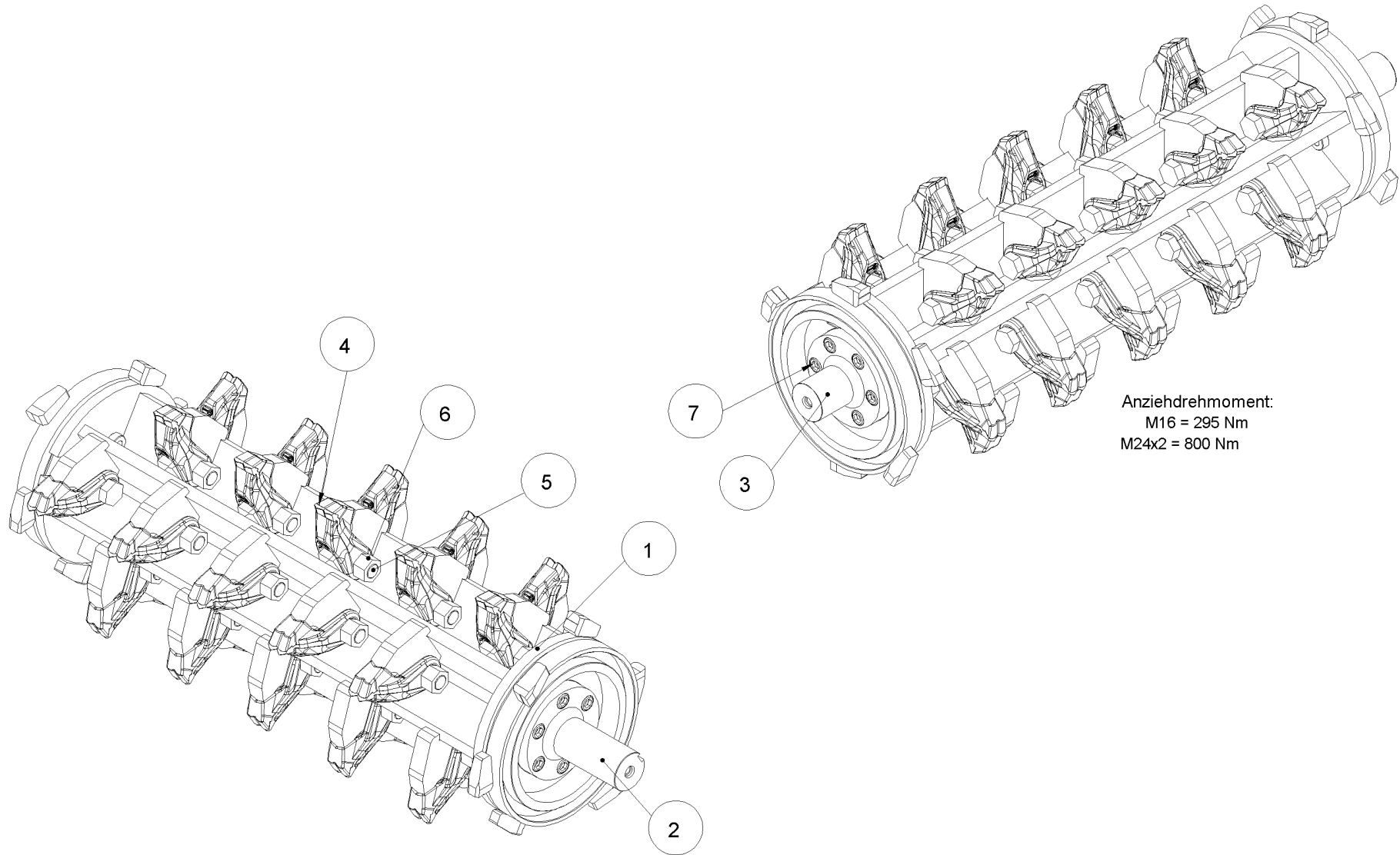









Anziehdrehmoment:
M16 = 295 Nm
M24x2 = 800 Nm

ROTOR D450 1100 30XHDT01.A - ROTOR D450 1100 30XHDT01.A
 ROTOR D450 1100 30XHDT01.A - 740.03.00.01.00/C

740.03.00.01.00/C
 Stücklistennummer / Piece Number / Liste de Pièces / Номер



Pos.		Bestell-Nr. Stock Number Numéro de Commande Номер товара	Menge Amount Quantité Количество	Beschreibung	Description	Description	Описание
10		740.03.01.00.00/E	1,000	ROTOR M450H GESCHWEISST	ROTOR M450H WELDED	ROTOR M450H WELDED	
20		754.03.00.00.01/I	1,000	ROTORWELLENSTUMMEL D65	ROTOR SHAFT STUB FM500	ROTOR SHAFT STUB FM500	
30		740.03.00.00.01/01	1,000	ROTORSTUMMEL KURZ	ROTOR SHOFT	ROTOR SHOFT	
40		46.HDT01.A/B	30,0-00	WERKZEUG HDT01.A	TOOL HDT01.A	OUTIL HDT01.A	
50		01.80.24.T.085.C	30,0-00	SKT-SCHRAUBE M24X85X2	HEX. SCREW M24X2X85-10.9DIN960	HEX. SCREW M24X2X85-10.9DIN960	
60		03.03.24.T.C	30,0-00	SKT-MUTTER M24X2 10, SELBSTSICH.	NUT M24X2 DIN980 SE.-LOCK.	NUT M24X2 DIN980 SE.-LOCK.	
70		01.21.16050.C	12,0-00	ZYLINDERSCHRAUBE M16X50	SCREW M16X50 DIN6912	SCREW M16X50 DIN6912	

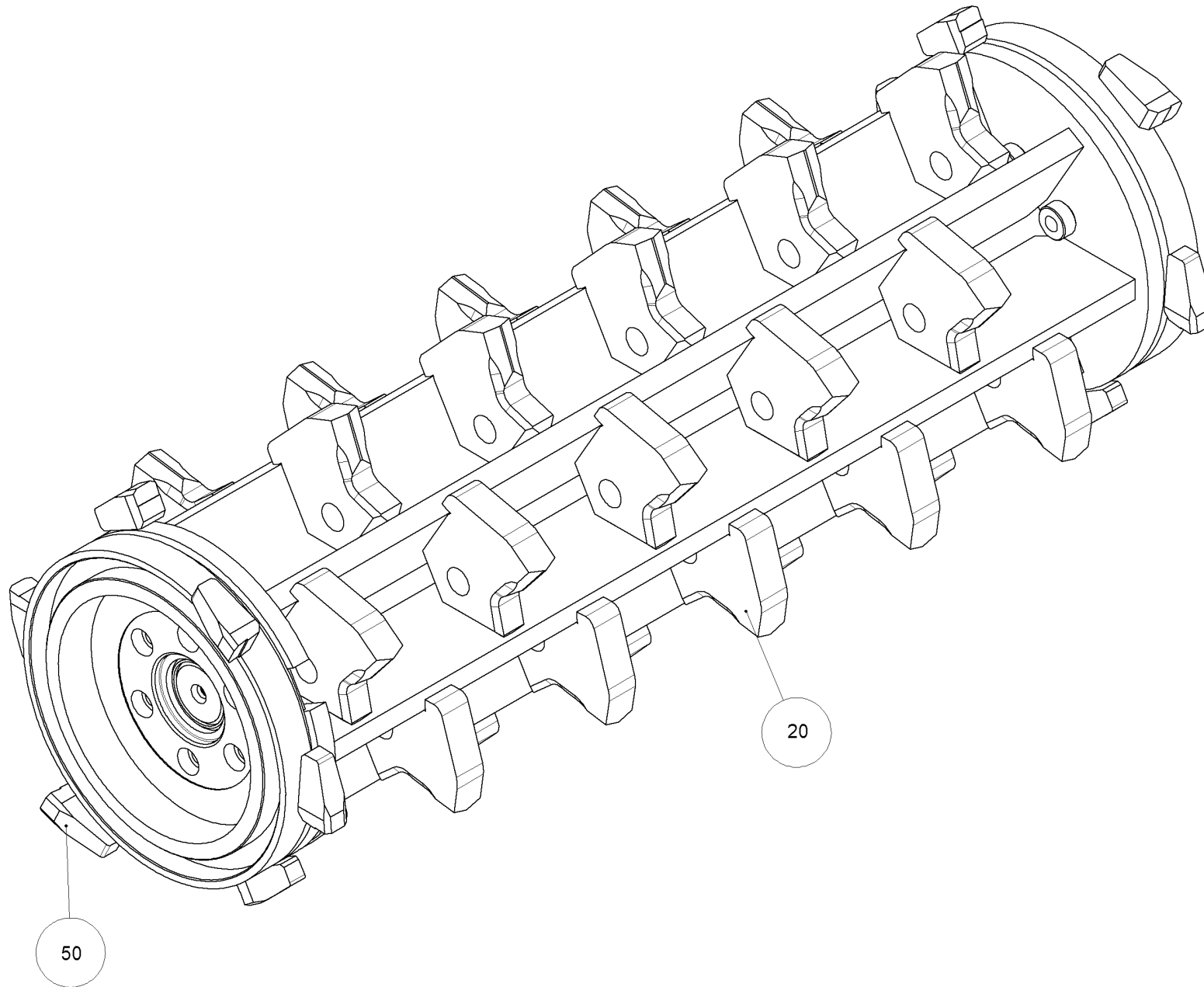

ROTOR M450H GESCHWEISST - ROTOR M450H WELDED
 ROTOR M450H WELDED - 740.03.01.00.00/E

740.03.01.00.00/E
 Stücklistennummer / Piece Number / Liste de Pièces / Номер



Pos.		Bestell-Nr. Stock Number Numéro de Commande Номер товара	Menge Amount Quantité Количество	Beschreibung	Description	Description	Описание
20		740.03.01.00.01/F	30,0-00	MEISSELHALTERUNG HDT ROTOR D450	MEISSELHALTERUNG HDT ROTOR D450	MEISSELHALTERUNG HDT ROTOR D450	
50		46.BFZ25.G/00	12,0-00	WERKZEUG BFZ25.G	TOOL BFZ25.G	OUTIL BFZ25.G	

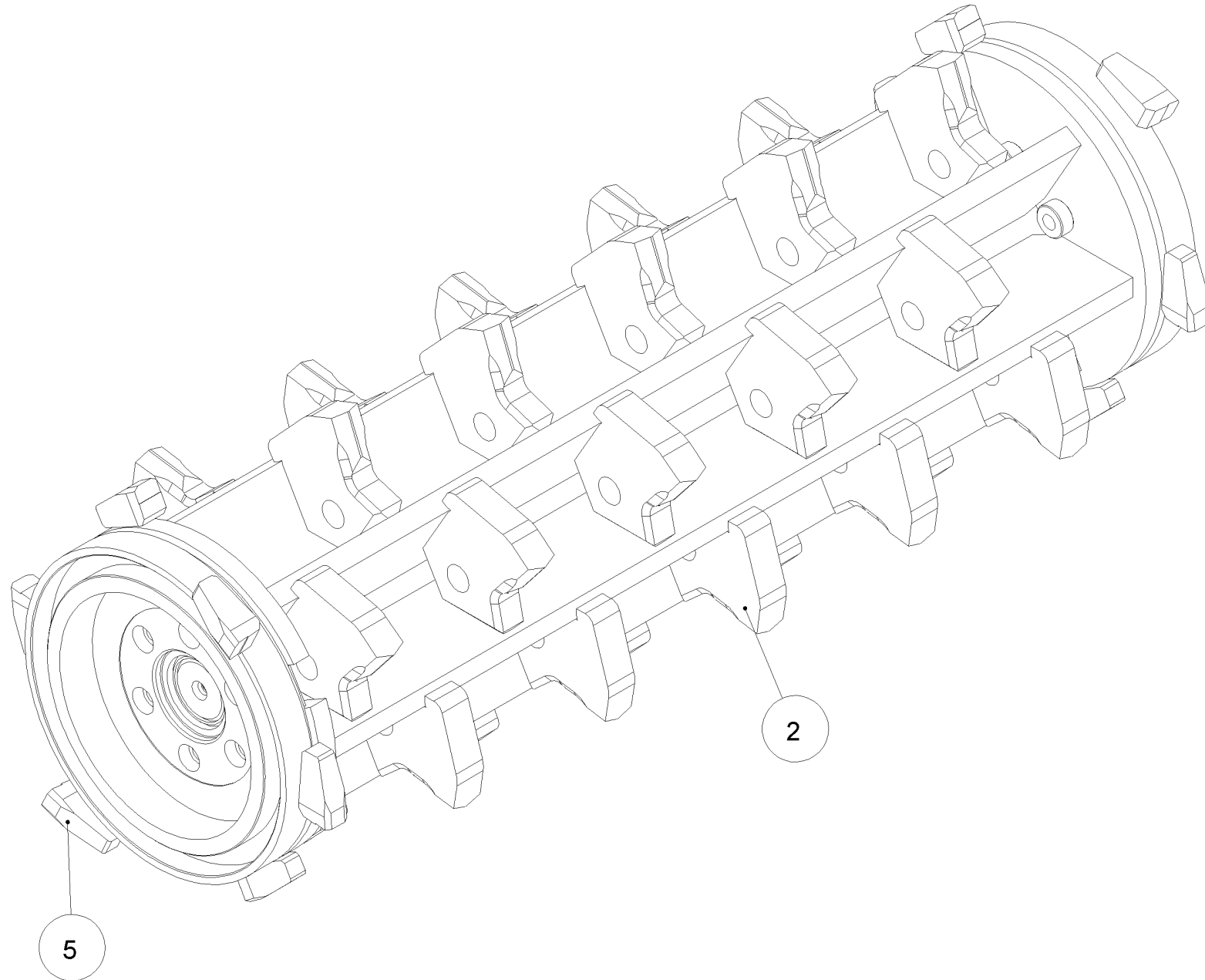

ROTOR M450H GESCHWEISST - ROTOR M450H WELDED
 ROTOR M450H WELDED - 740.03.01.00.00/E

740.03.01.00.00/E
 Stücklistennummer / Piece Number / Liste de Pièces / Номер



Pos.	Bestell-Nr. Stock Number Numéro de Commande Номер товара	Menge Amount Quantité Количество	Beschreibung	Description	Description	Описание
20	 740.03.01.00.01/F	30,0-00	MEISSELHALTERUNG HDT ROTOR D450	MEISSELHALTERUNG HDT ROTOR D450	MEISSELHALTERUNG HDT ROTOR D450	
50	 46.BFZ25.G/00	12,0-00	WERKZEUG BFZ25.G	TOOL BFZ25.G	OUTIL BFZ25.G	

ROTORSTUMMEL KURZ - ROTOR SHOFT
ROTOR SHOFT - 740.03.00.00.01/01

740.03.00.00.01/01
Stücklistennummer / Piece Number / Liste de Pièces / Homep



ROTORSTUMMEL KURZ - ROTOR SHOFT
ROTOR SHOFT - 740.03.00.00.01/01

740.03.00.00.01/01
Stücklistennummer / Piece Number / Liste de Pièces / Номер



Pos.	Bestell-Nr. Stock Number Numéro de Commande Номер товара	Menge Amount Quantité Количество	Beschreibung	Description	Description	Описание
------	---	---	--------------	-------------	-------------	----------



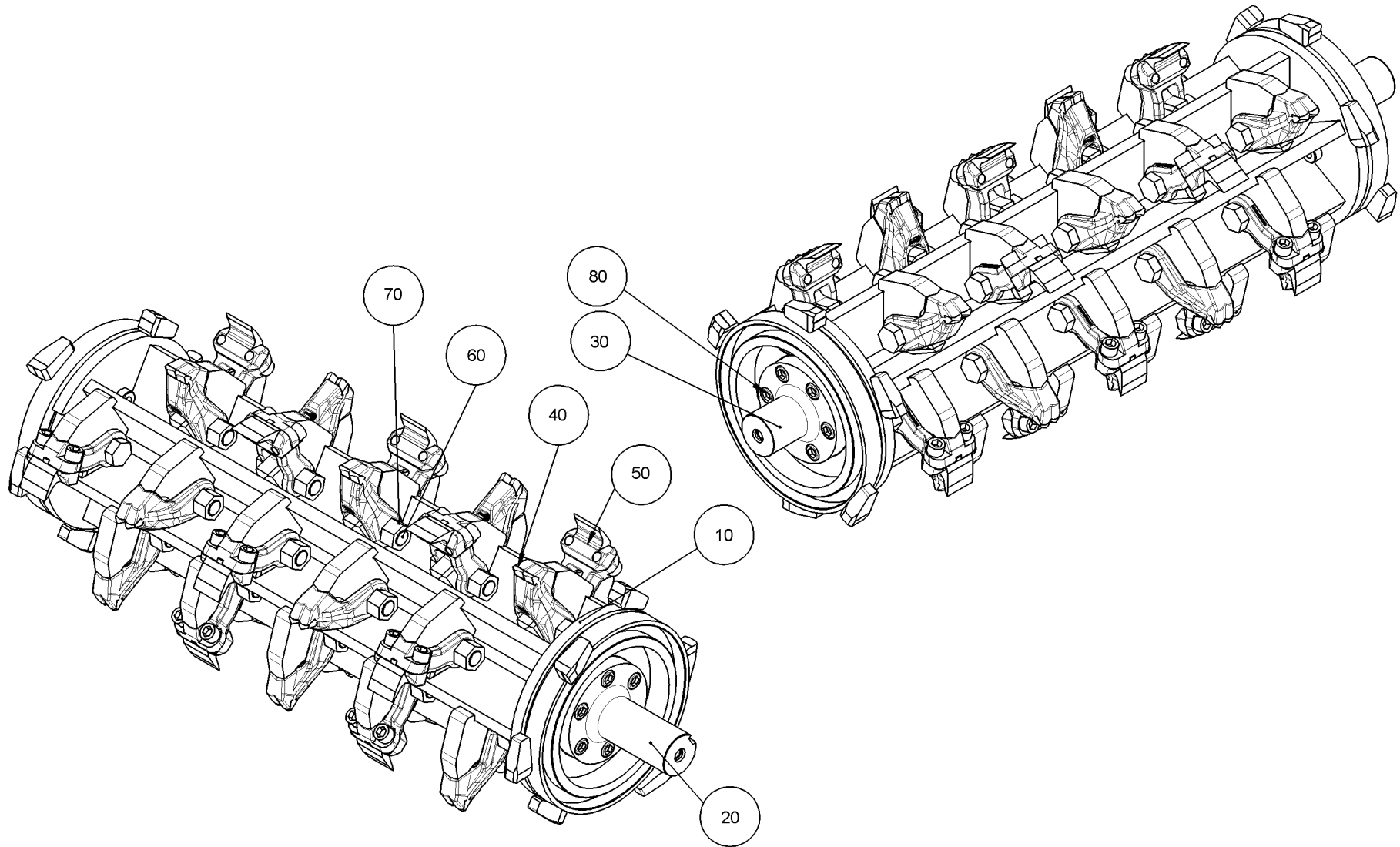







1	 754.03.00.00.01/1	1,000	ROTORWELLENSTUMMEL D65	ROTOR SHAFT STUB FM500	ROTOR SHAFT STUB FM500	
---	---	-------	------------------------	------------------------	------------------------	--



ROTOR D450 1100 GEMISCHT - ROTOR M450H MIXED
 ROTOR M450H MIXED - 740.03.00.02.00/A

740.03.00.02.00/A
 Stücklistennummer / Piece Number / Liste de Pièces / Номер



Pos.		Bestell-Nr. Stock Number Numéro de Commande Номер товара	Menge Amount Quantité Количество	Beschreibung	Description	Description	Описание
10		740.03.01.00.00/E	1,000	ROTOR M450H GESCHWEISST	ROTOR M450H WELDED	ROTOR M450H WELDED	
20		754.03.00.00.01/I	1,000	ROTORWELLENSTUMMEL D65	ROTOR SHAFT STUB FM500	ROTOR SHAFT STUB FM500	
30		740.03.00.00.01/01	1,000	ROTORSTUMMEL KURZ	ROTOR SHOFT	ROTOR SHOFT	
40		46.HDT01.A/B	15,0-00	WERKZEUG HDT01.A	TOOL HDT01.A	OUTIL HDT01.A	
50		46.HM017/B	15,0-00	WERKZEUG-HALTER HM017	TOOL-SUPPORT HM017	OUTIL-SUPPORT HM017	
60		46.HM028.02.A/B	15,0-00	WERKZEUG HARTMETALL SCHARF	CHIPPER BLADE	CHIPPER BLADE	
70		01.20.16035.C	30,0-00	ZYLINDERSCHRAUBE M16X35 10.9 VERGÜETET	SCREW M16X35 DIN912	SCREW M16X35 DIN912	
80		01.80.24.T.085.C	30,0-00	SKT-SCHRAUBE M24X85X2	HEX. SCREW M24X2X85-10.9DIN960	HEX. SCREW M24X2X85-10.9DIN960	
90		03.03.24.T.C	30,0-00	SKT-MUTTER M24X2 10, SELBSTSICH.	NUT M24X2 DIN980 SE.-LOCK.	NUT M24X2 DIN980 SE.-LOCK.	
100		01.21.16050.C	12,0-00	ZYLINDERSCHRAUBE M16X50	SCREW M16X50 DIN6912	SCREW M16X50 DIN6912	

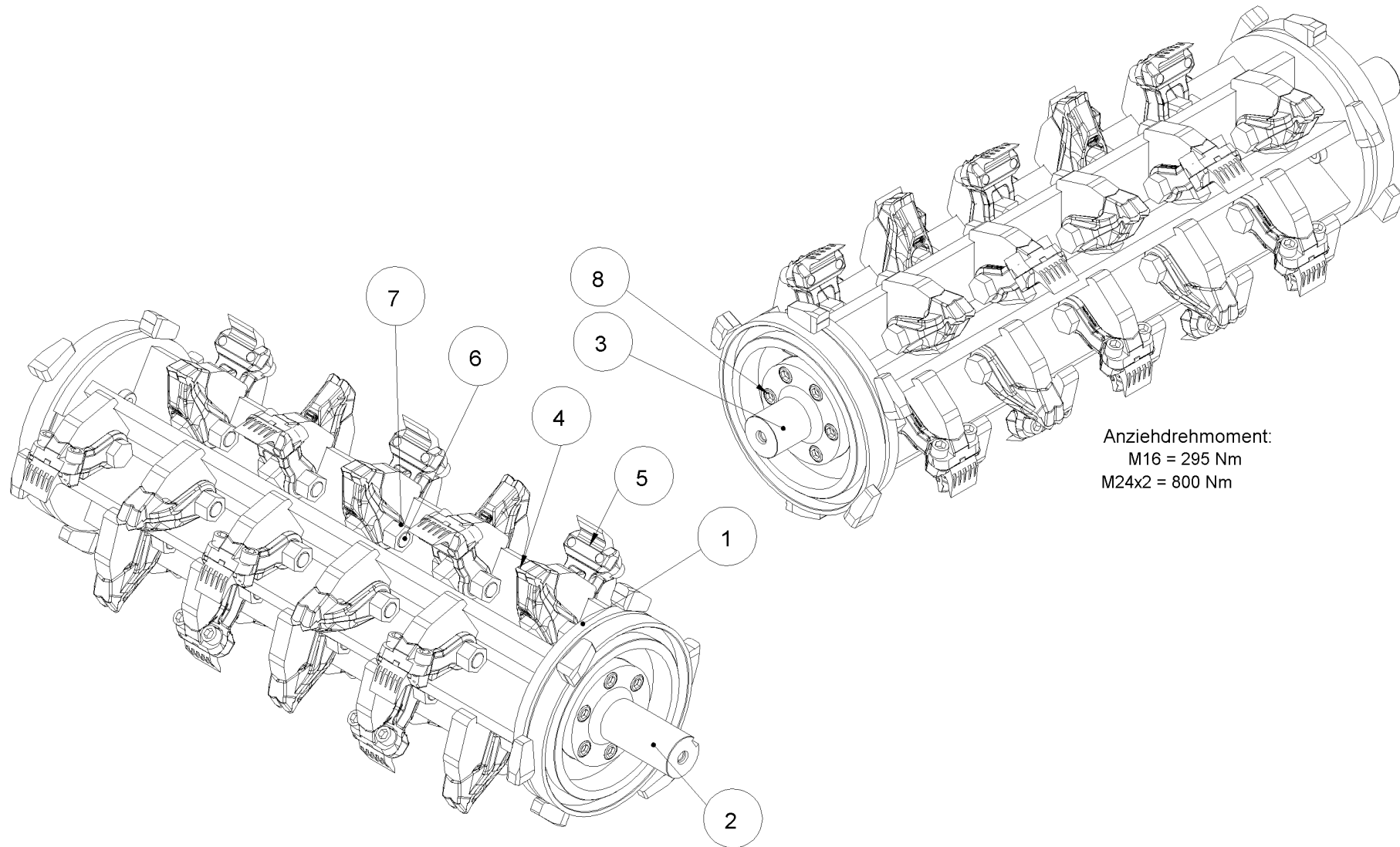











Anziehdrehmoment:
M16 = 295 Nm
M24x2 = 800 Nm

ROTOR D450 1100 GEMISCHT - ROTOR M450H MIXED
 ROTOR M450H MIXED - 740.03.00.02.00/A

740.03.00.02.00/A
 Stücklistennummer / Piece Number / Liste de Pièces / Номер



Pos.		Bestell-Nr. Stock Number Numéro de Commande Номер товара	Menge Amount Quantité Количество	Beschreibung	Description	Description	Описание
10		740.03.01.00.00/E	1,000	ROTOR M450H GESCHWEISST	ROTOR M450H WELDED	ROTOR M450H WELDED	
20		754.03.00.00.01/I	1,000	ROTORWELLENSTUMMEL D65	ROTOR SHAFT STUB FM500	ROTOR SHAFT STUB FM500	
30		740.03.00.00.01/01	1,000	ROTORSTUMMEL KURZ	ROTOR SHOFT	ROTOR SHOFT	
40		46.HDT01.A/B	15,0-00	WERKZEUG HDT01.A	TOOL HDT01.A	OUTIL HDT01.A	
50		46.HM017/B	15,0-00	WERKZEUG-HALTER HM017	TOOL-SUPPORT HM017	OUTIL-SUPPORT HM017	
60		46.HM028.02.A/B	15,0-00	WERKZEUG HARTMETALL SCHARF	CHIPPER BLADE	CHIPPER BLADE	
70		01.20.16035.C	30,0-00	ZYLINDERSCHRAUBE M16X35 10.9 VERGÜETET	SCREW M16X35 DIN912	SCREW M16X35 DIN912	
80		01.80.24.T.085.C	30,0-00	SKT-SCHRAUBE M24X85X2	HEX. SCREW M24X2X85-10.9DIN960	HEX. SCREW M24X2X85-10.9DIN960	
90		03.03.24.T.C	30,0-00	SKT-MUTTER M24X2 10, SELBSTSICH.	NUT M24X2 DIN980 SE.-LOCK.	NUT M24X2 DIN980 SE.-LOCK.	
100		01.21.16050.C	12,0-00	ZYLINDERSCHRAUBE M16X50	SCREW M16X50 DIN6912	SCREW M16X50 DIN6912	

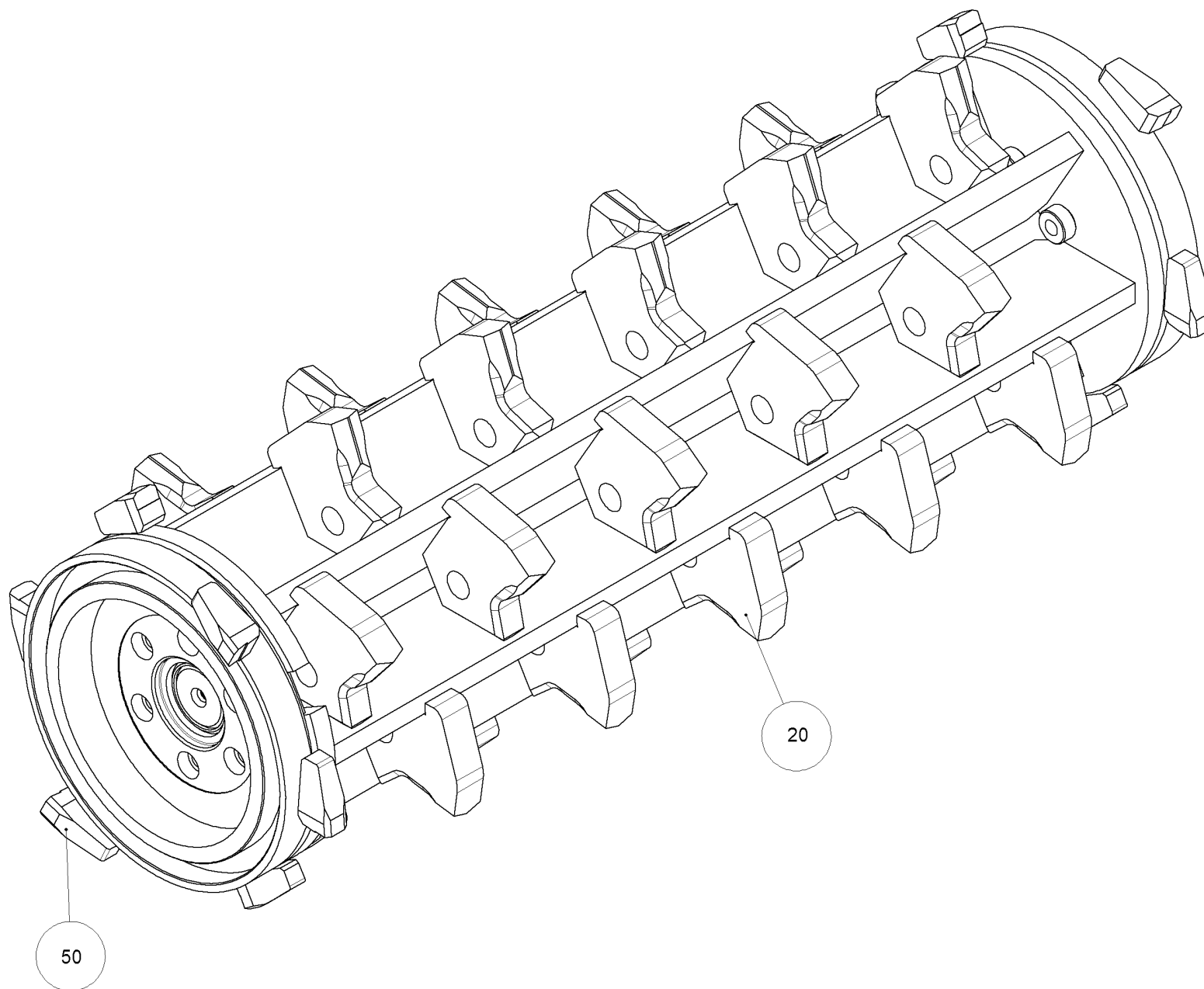

ROTOR M450H GESCHWEISST - ROTOR M450H WELDED
 ROTOR M450H WELDED - 740.03.01.00.00/E

740.03.01.00.00/E
 Stücklistennummer / Piece Number / Liste de Pièces / Номер



Pos.	Bestell-Nr. Stock Number Numéro de Commande Номер товара	Menge Amount Quantité Количество	Beschreibung	Description	Description	Описание
20	 740.03.01.00.01/F	30,0-00	MEISSELHALTERUNG HDT ROTOR D450	MEISSELHALTERUNG HDT ROTOR D450	MEISSELHALTERUNG HDT ROTOR D450	
50	 46.BFZ25.G/00	12,0-00	WERKZEUG BFZ25.G	TOOL BFZ25.G	OUTIL BFZ25.G	

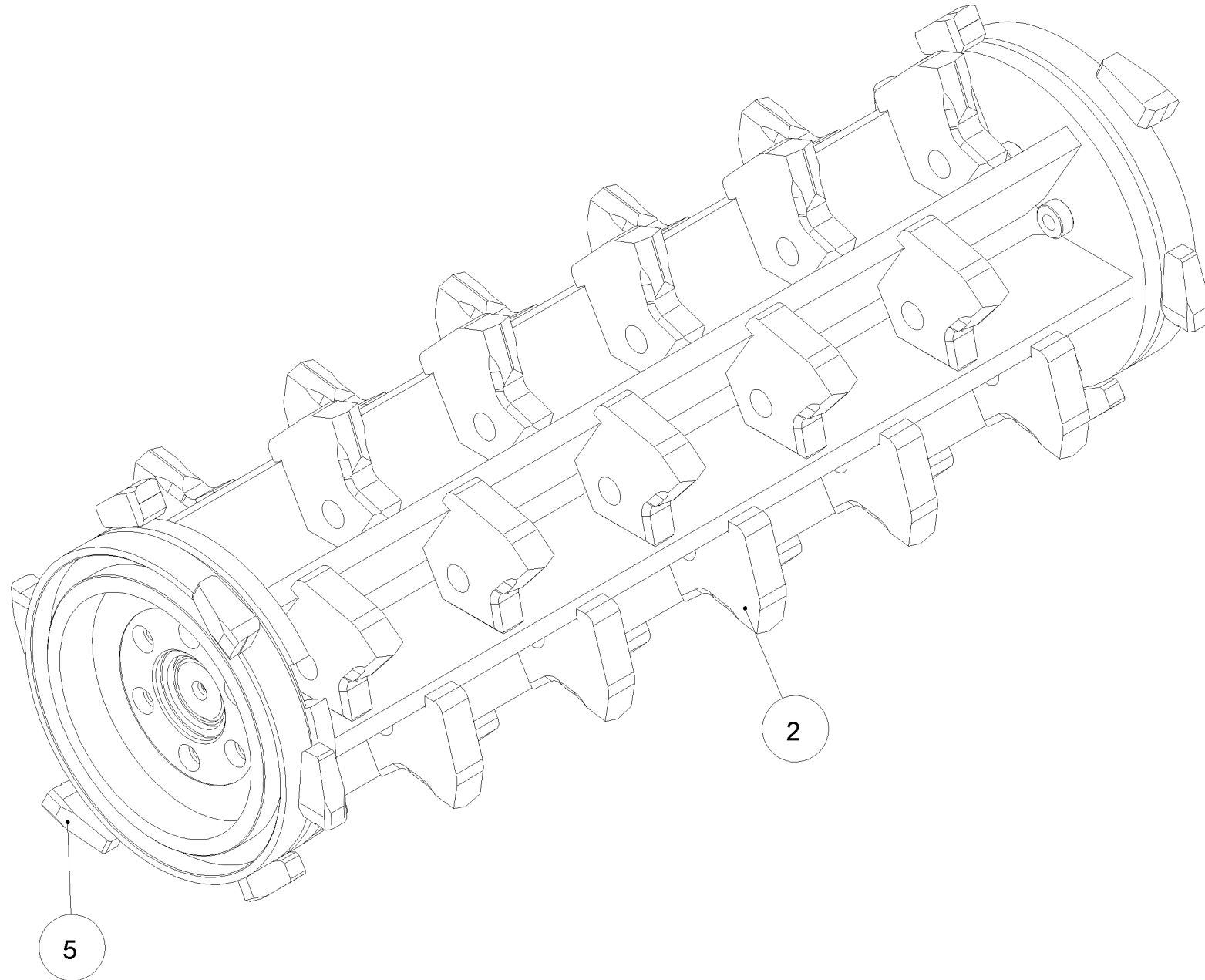

ROTOR M450H GESCHWEISST - ROTOR M450H WELDED
 ROTOR M450H WELDED - 740.03.01.00.00/E

740.03.01.00.00/E
 Stücklistennummer / Piece Number / Liste de Pièces / Номер



Pos.	Bestell-Nr. Stock Number Numéro de Commande Номер товара	Menge Amount Quantité Количество	Beschreibung	Description	Description	Описание
20	 740.03.01.00.01/F	30,0-00	MEISSELHALTERUNG HDT ROTOR D450	MEISSELHALTERUNG HDT ROTOR D450	MEISSELHALTERUNG HDT ROTOR D450	
50	 46.BFZ25.G/00	12,0-00	WERKZEUG BFZ25.G	TOOL BFZ25.G	OUTIL BFZ25.G	

ROTORSTUMMEL KURZ - ROTOR SHOFT
ROTOR SHOFT - 740.03.00.00.01/01

740.03.00.00.01/01
Stücklistennummer / Piece Number / Liste de Pièces / Homep



ROTORSTUMMEL KURZ - ROTOR SHOFT
ROTOR SHOFT - 740.03.00.00.01/01







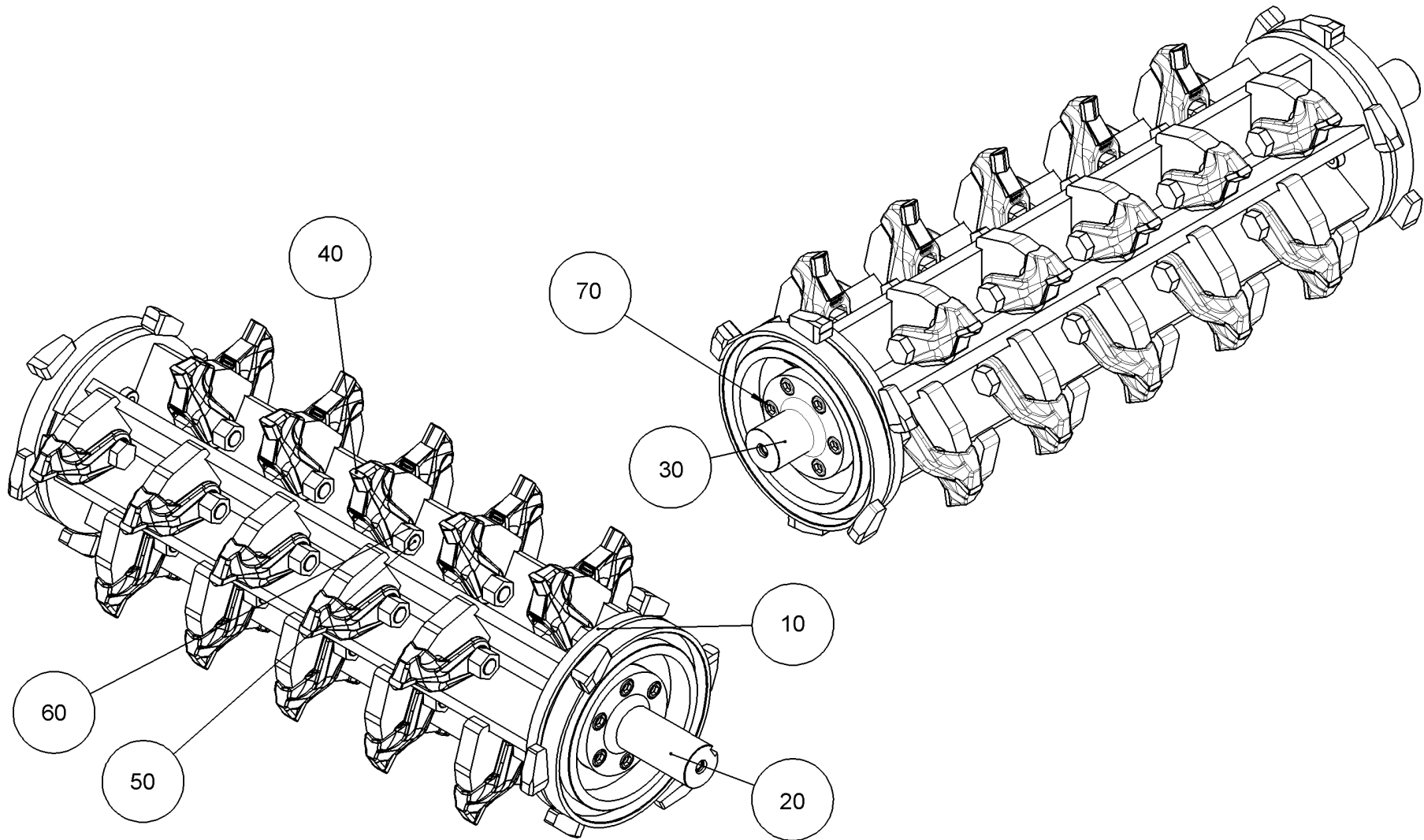

740.03.00.00.01/01
Stücklistennummer / Piece Number / Liste de Pièces / Номер



Pos.	Bestell-Nr. Stock Number Numéro de Commande Номер товара	Menge Amount Quantité Количество	Beschreibung	Description	Description	Описание
------	---	---	--------------	-------------	-------------	----------

1	 754.03.00.00.01/1	1,000	ROTORWELLENSTUMMEL D65	ROTOR SHAFT STUB FM500	ROTOR SHAFT STUB FM500	
---	---	-------	------------------------	------------------------	------------------------	--



Pos.		Bestell-Nr. Stock Number Numéro de Commande Номер товара	Menge Amount Quantité Количество	Beschreibung	Description	Description	Описание
10		740.03.01.00.00/E	1,000	ROTOR M450H GESCHWEISST	ROTOR M450H WELDED	ROTOR M450H WELDED	
20		46.HDT04.V/A	30,0- 00	WERKZEUG HDT04.V	TOOL HDT04.V	OUTIL HDT04.V	
30		754.03.00.00.01/I	1,000	ROTORWELLENSTUMMEL D65	ROTOR SHAFT STUB FM500	ROTOR SHAFT STUB FM500	
40		01.80.24.T.085.C	30,0- 00	SKT-SCHRAUBE M24X85X2	HEX. SCREW M24X2X85-10.9DIN960	HEX. SCREW M24X2X85-10.9DIN960	
50		03.03.24.T.C	30,0- 00	SKT-MUTTER M24X2 10, SELBSTSICH.	NUT M24X2 DIN980 SE.-LOCK.	NUT M24X2 DIN980 SE.-LOCK.	
60		01.21.16050.C	12,0- 00	ZYLINDERSCHRAUBE M16X50	SCREW M16X50 DIN6912	SCREW M16X50 DIN6912	
70		740.03.00.00.01/01	1,000	ROTORSTUMMEL KURZ	ROTOR SHOFT	ROTOR SHOFT	

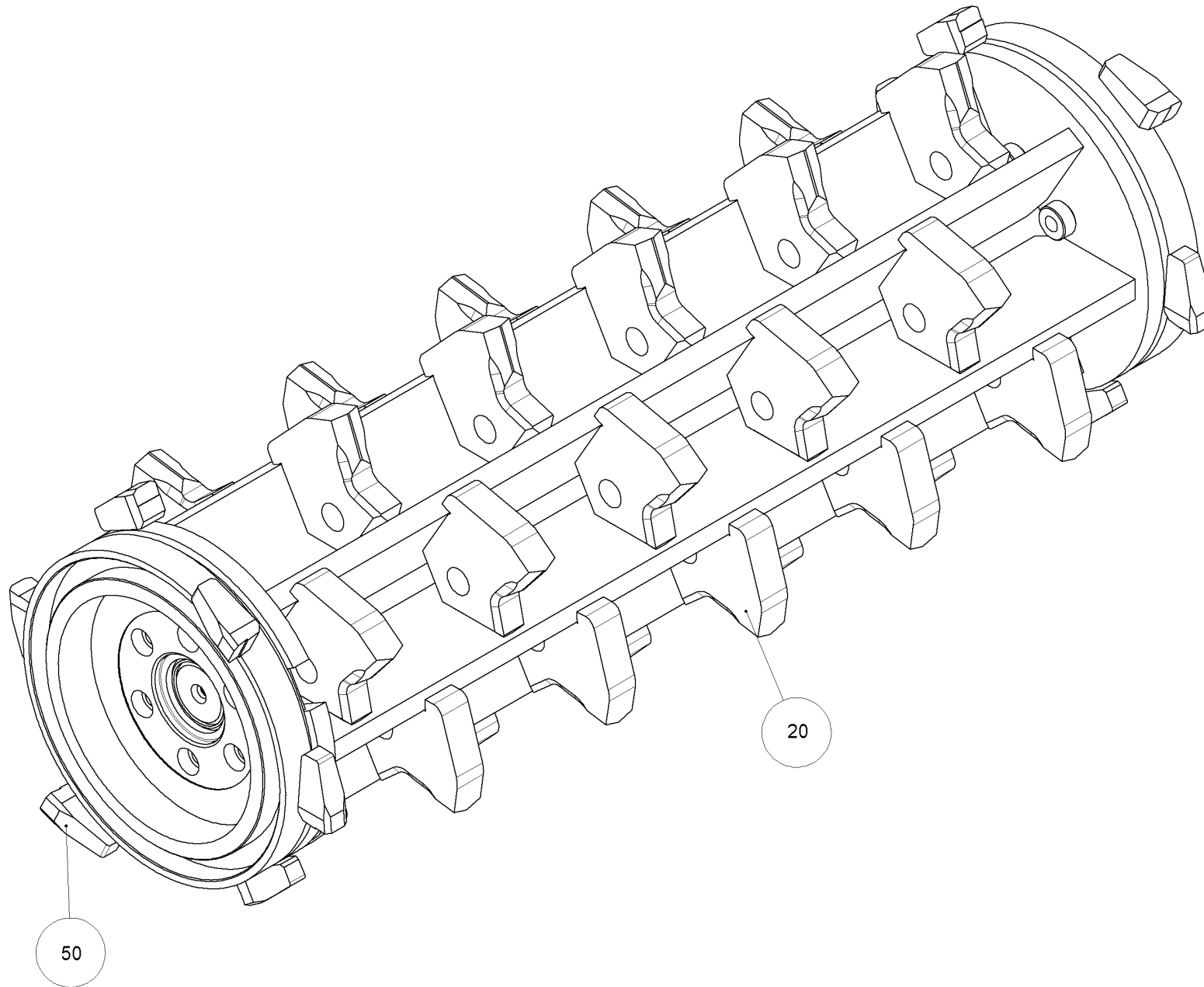

ROTOR M450H GESCHWEISST - ROTOR M450H WELDED
 ROTOR M450H WELDED - 740.03.01.00.00/E

740.03.01.00.00/E
 Stücklistennummer / Piece Number / Liste de Pièces / Номер



Pos.	Bestell-Nr. Stock Number Numéro de Commande Номер товара	Menge Amount Quantité Количество	Beschreibung	Description	Description	Описание
20	 740.03.01.00.01/F	30,0-00	MEISSELHALTERUNG HDT ROTOR D450	MEISSELHALTERUNG HDT ROTOR D450	MEISSELHALTERUNG HDT ROTOR D450	
50	 46.BFZ25.G/00	12,0-00	WERKZEUG BFZ25.G	TOOL BFZ25.G	OUTIL BFZ25.G	

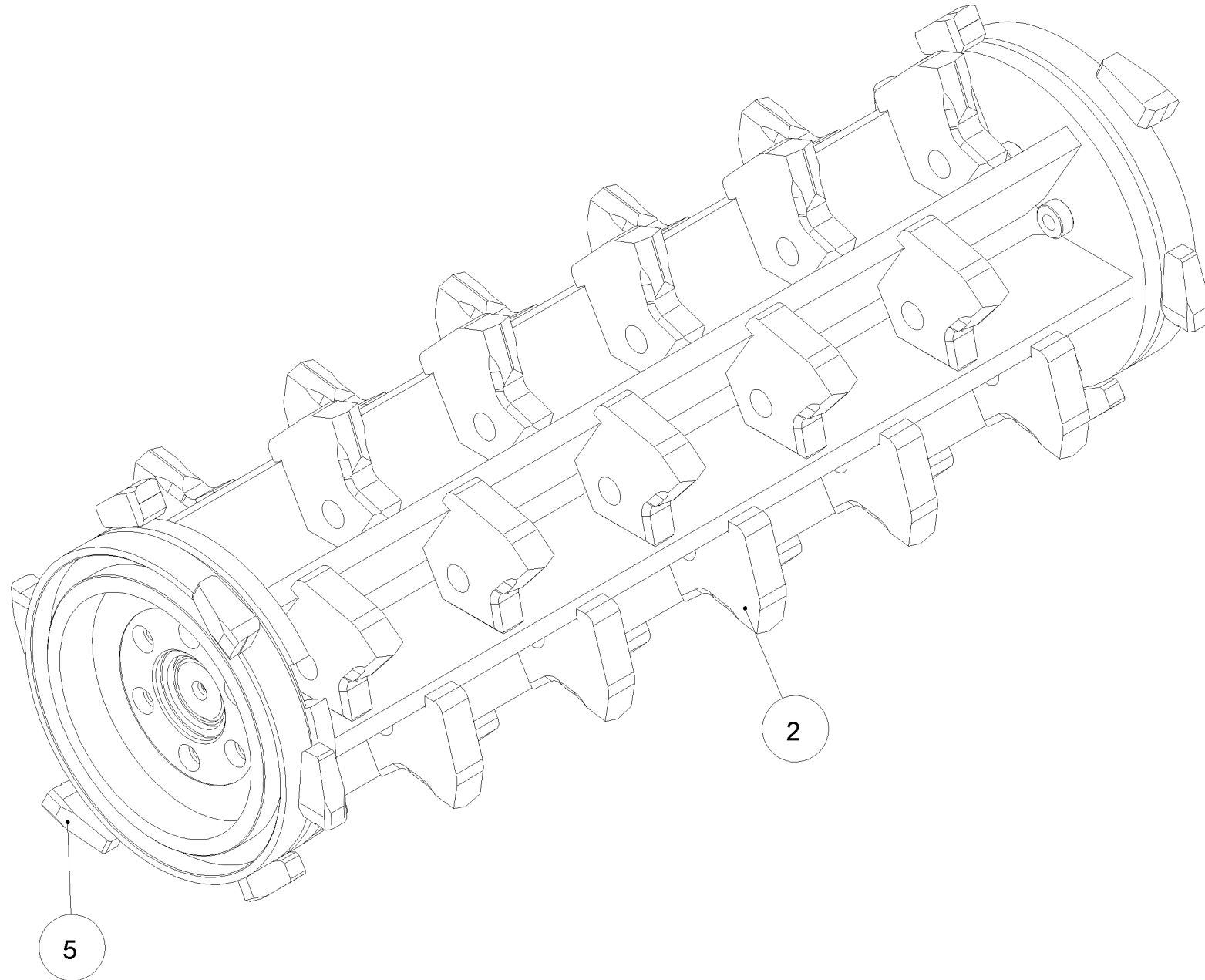

ROTOR M450H GESCHWEISST - ROTOR M450H WELDED
 ROTOR M450H WELDED - 740.03.01.00.00/E

740.03.01.00.00/E
 Stücklistennummer / Piece Number / Liste de Pièces / Номер



Pos.	Bestell-Nr. Stock Number Numéro de Commande Номер товара	Menge Amount Quantité Количество	Beschreibung	Description	Description	Описание
20	 740.03.01.00.01/F	30,0-00	MEISSELHALTERUNG HDT ROTOR D450	MEISSELHALTERUNG HDT ROTOR D450	MEISSELHALTERUNG HDT ROTOR D450	
50	 46.BFZ25.G/00	12,0-00	WERKZEUG BFZ25.G	TOOL BFZ25.G	OUTIL BFZ25.G	

ROTORSTUMMEL KURZ - ROTOR SHOFT
ROTOR SHOFT - 740.03.00.00.01/01

740.03.00.00.01/01
Stücklistennummer / Piece Number / Liste de Pièces / Homep



ROTORSTUMMEL KURZ - ROTOR SHOFT
ROTOR SHOFT - 740.03.00.00.01/01

740.03.00.00.01/01
Stücklistennummer / Piece Number / Liste de Pièces / Номер



Pos.	Bestell-Nr. Stock Number Numéro de Commande Номер товара	Menge Amount Quantité Количество	Beschreibung	Description	Description	Описание
------	---	---	--------------	-------------	-------------	----------

1	 754.03.00.00.01/1	1,000	ROTORWELLENSTUMMEL D65	ROTOR SHAFT STUB FM500	ROTOR SHAFT STUB FM500	
---	---	-------	------------------------	------------------------	------------------------	--

LABYRINTHDICHTUNG HDT ROTOR - LABYRINTH SEAL RING FOR HDT
LABYRINTH SEAL RING FOR HDT - 470.03.00.02.00/00

470.03.00.02.00/00

Stücklistennummer / Piece Number / Liste de Pièces / Homep



LABYRINTHDICHTUNG HDT ROTOR - LABYRINTH SEAL RING FOR HDT
 LABYRINTH SEAL RING FOR HDT - 470.03.00.02.00/00

470.03.00.02.00/00
 Stücklistennummer / Piece Number / Liste de Pièces / Номер



Pos.	Bestell-Nr. Stock Number Numéro de Commande Номер товара	Menge Amount Quantité Количество	Beschreibung	Description	Description	Описание
------	---	---	--------------	-------------	-------------	----------



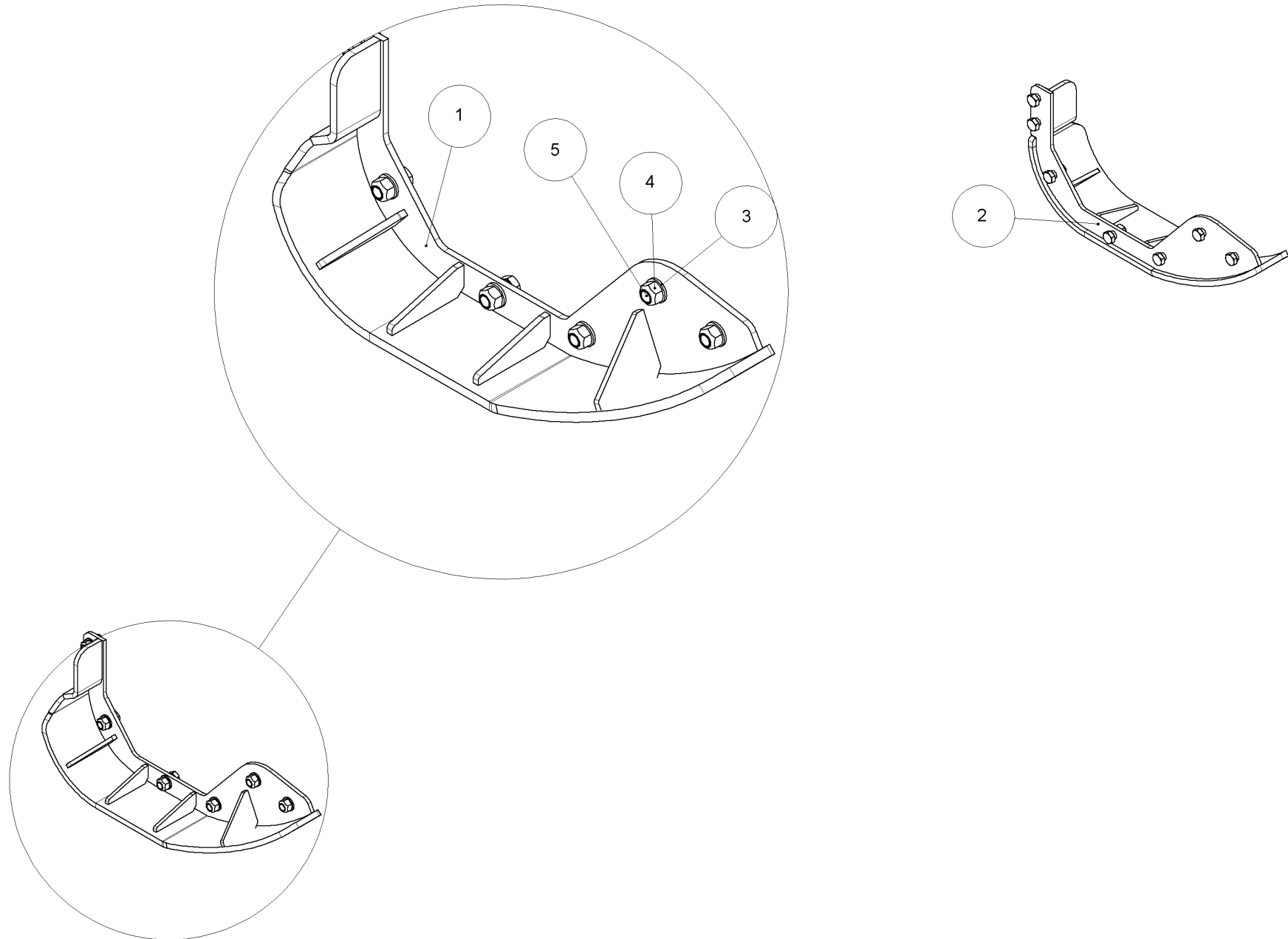



10	 777.02.01.00.02/A	2,000	GEGENFLANSCH ROTORLAGER	COUNTER FLANGE ROTOR BEARING	COUNTER FLANGE ROTOR BEARING	
----	---	-------	-------------------------	------------------------------	------------------------------	--



KUFEN OHNE UNTERSCHNITT SATZ M450 - SKIDS
SKIDS - 450.06.00.00.00/00

450.06.00.00.00/00
Stücklistennummer / Piece Number / Liste de Pièces / Номер



Pos.		Bestell-Nr. Stock Number Numéro de Commande Номер товара	Menge Amount Quantité Количество	Beschreibung	Description	Description	Описание
10		450.06.21.00.00/B	1,000	KUFE LINKS	KUFE LINKS	KUFE LINKS	
20		450.06.20.00.00/B	1,000	KUFE RECHTS	KUFE RECHTS	KUFE RECHTS	
30		05.01.17	14,0-00	SCHEIBE ISO 7090-17-200HV	WASHER B17 DIN 125 GALVANIZED	WASHER B17 DIN 125 GALVANIZED	
40		03.02.16	14,0-00	SKT-MUTTER M16 8, SELBSTSICH.	NUT M16 DIN980V SELF- LOCKING	NUT M16 DIN980V SELF- LOCKING	
50		01.10.16035	14,0-00	SKT-SCHRAUBE M16X35 8.8	SCREW M16X35 DIN 933	SCREW M16X35 DIN 933	

KLAPPE-GESCHRAUBT - SHUTTER-SCREWED
CLAPET-VISSE - 41320830/00

41320830/00

Stücklistennummer / Piece Number / Liste de Pièces / Homep



KLAPPE-GESCHRAUBT - SHUTTER-SCREWED
CLAPET-VISSE - 41320830/00

41320830/00

Stücklistennummer / Piece Number / Liste de Pièces / Номер



Pos.		Bestell-Nr. Stock Number Numéro de Commande Номер товара	Menge Amount Quantité Количество	Beschreibung	Description	Description	Описание
10		740.10.01.00.00/D	1,000	KLAPPE GESCHWEISST	KLAPPE GESCHWEISST	KLAPPE GESCHWEISST	
20		01.01.45.16025/A	2,000	SCHMIERSCHRAUBE M16X25 M. SCH.	GREASE SCREW M16X25	GREASE SCREW M16X25	
30		01.10.16080	2,000	SKT-SCHRAUBE M16X80 8.8	SCREW M16X80 DIN933	SCREW M16X80 DIN933	
40		03.02.16	2,000	SKT-MUTTER M16 8, SELBSTSICH.	NUT M16 DIN980V SELF- LOCKING	NUT M16 DIN980V SELF- LOCKING	
50		05.01.17	2,000	SCHEIBE ISO 7090-17-200HV	WASHER B17 DIN 125 GALVANIZED	WASHER B17 DIN 125 GALVANIZED	
60		07.01.16	2,000	FEDERRING B16	SPRING WASHER B16 DIN127 GALV.	SPRING WASHER B16 DIN127 GALV.	
70		12.40.44.30/00	2,000	GLEITBUCHSE	SLIDE BUSHING	DOUILLE DE GLISSEMENT	
80		20.02.14.08.0500.B	2,000	HYDRAULIKSCHLAUCH	HYDRAULIC HOSE	BOYAU HYDRAULIQUE	
90		20.BUZ08L/00	2,000	VERSCHLUSSTOPFEN 8L PN500 SW17	FITTING FOR MEASURE 8L C/ NUT	FITTING FOR MEASURE 8L C/ NUT	
100		20.GEV08L.M14-1.5/00	4,000	GER-EINSCHR-VERSCHR. 8L	MALE STUD COUPLING 08L M14-1.5	MALE STUD COUPLING 08L M14-1.5	
110		20.SWVE8L-1-4/00	2,000	SCHWENKVERSCHR. 8L G 1/4	SCHWENKVERSCHR. 8L G 1/4	SCHWENKVERSCHR. 8L G 1/4	

KLAPPE-GESCHRAUBT - SHUTTER-SCREWED
CLAPET-VISSE - 41320830/00

41320830/00

Stücklistennummer / Piece Number / Liste de Pièces / Homep









KLAPPE-GESCHRAUBT - SHUTTER-SCREWED
CLAPET-VISSE - 41320830/00

41320830/00

Stücklistennummer / Piece Number / Liste de Pièces / Номер



Pos.		Bestell-Nr. Stock Number Numéro de Commande Номер товара	Menge Amount Quantité Количество	Beschreibung	Description	Description	Описание
120		20.UEM08L/00	2,000	UEBERWURFMUTTER 8L M14X1,5 PN500, SW17	UNION NUT 8L M14-1.5	UNION NUT 8L M14-1.5	
130		25.01.040.08	2,000	SPANNSTIFT 8X40 STAHL	SPRING PIN 8X40 DIN 1481	SPRING PIN 8X40 DIN 1481	
140		740.10.00.00.01/A	2,000	BOLZEN MIT BOHRUNG D40L141	BOLT	BOLT	
150		742.10.00.00.01/00	2,000	BOLZEN MIT BOHRUNG D25L72	BOLT	BOLT	
160		742.10.03.00.00/00	2,000	SCHUTZRING	PROTECTION RING	PROTECTION RING	
170		991.10.12.00.00/00	1,000	<u>HYDRAULIK-ZYLINDER</u>	HYDR. CYLINDER	HYDR. CYLINDER	

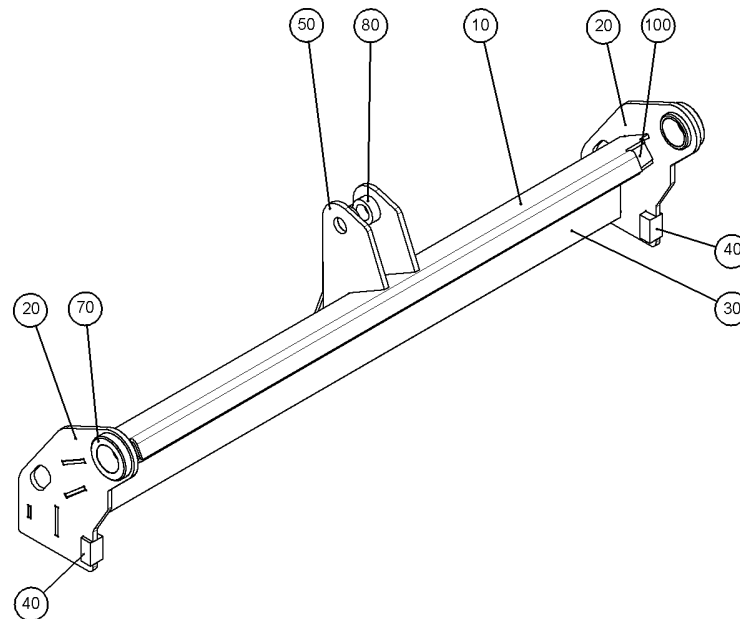
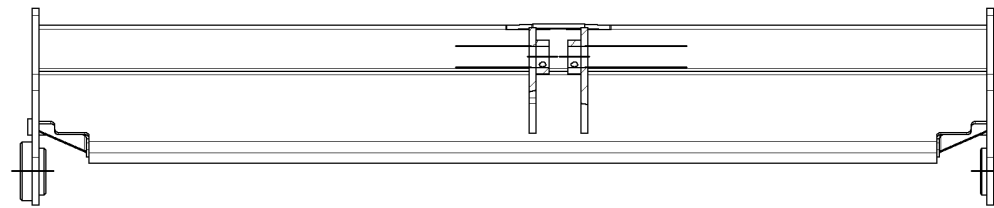
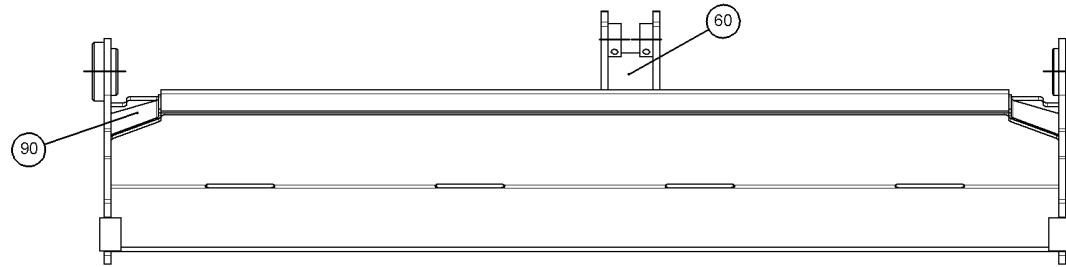

KLAPPE GESCHWEISST - Klappe geschweisst
KLAPPE GESCHWEISST - 740.10.01.00.00/D

740.10.01.00.00/D
Stücklistennummer / Piece Number / Liste de Pièces / Номер



Pos.	Bestell-Nr. Stock Number Numéro de Commande Номер товара	Menge Amount Quantité Количество	Beschreibung	Description	Description	Описание
------	---	---	--------------	-------------	-------------	----------

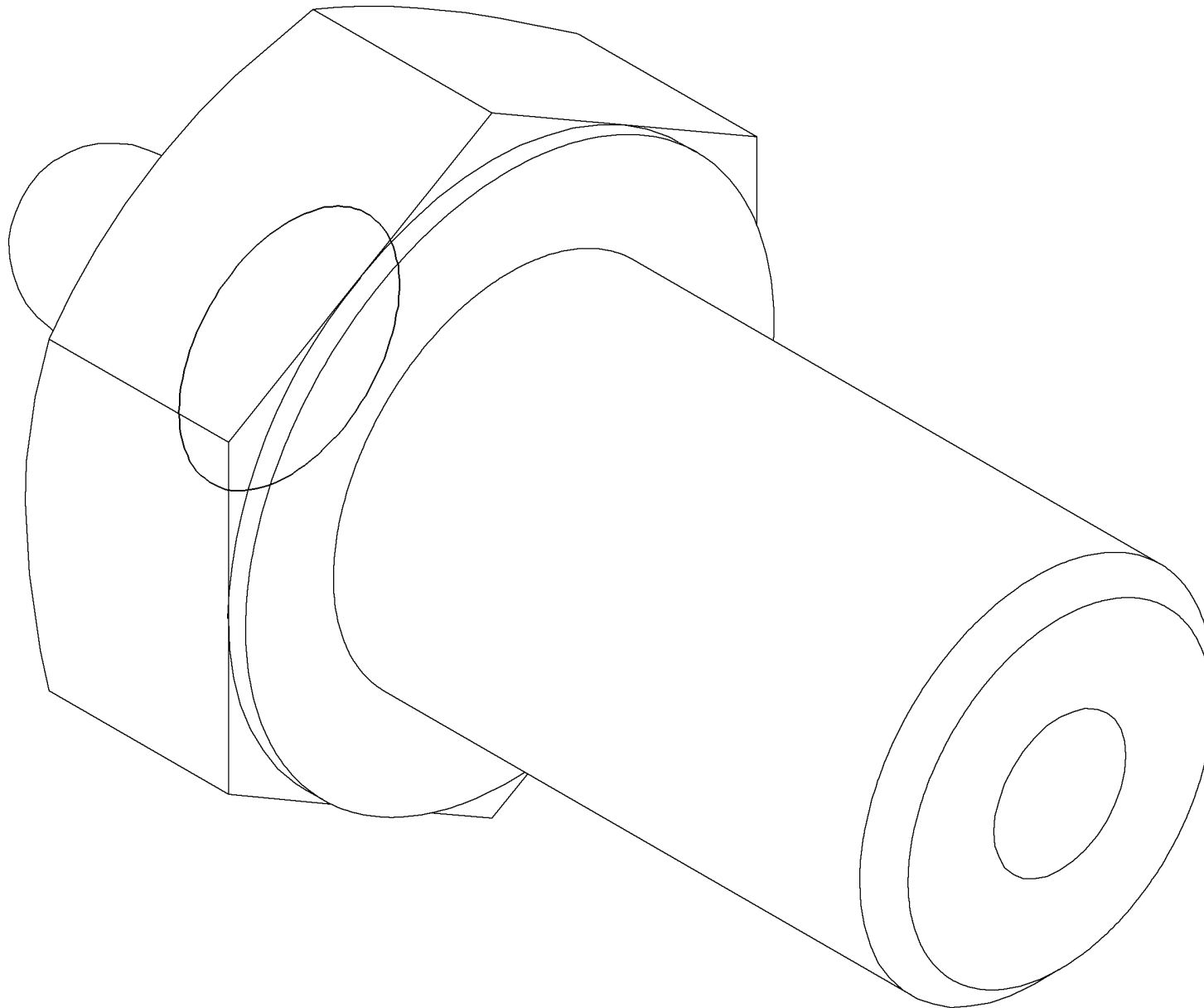

80	 08.01.25.16/00	2,000	STELLRING 25,2X40X16X8	ADJUSTING COLLAR 25,2X40X16X8	ADJUSTING COLLAR 25,2X40X16X8	
----	--	-------	------------------------	----------------------------------	----------------------------------	--



SCHMIERSCHRAUBE M16X25 M.SCH. - GREASE SCREW M16X25
 GREASE SCREW M16X25 - 01.01.45.16025/A

01.01.45.16025/A
 Stücklistennummer / Piece Number / Liste de Pièces / Номер



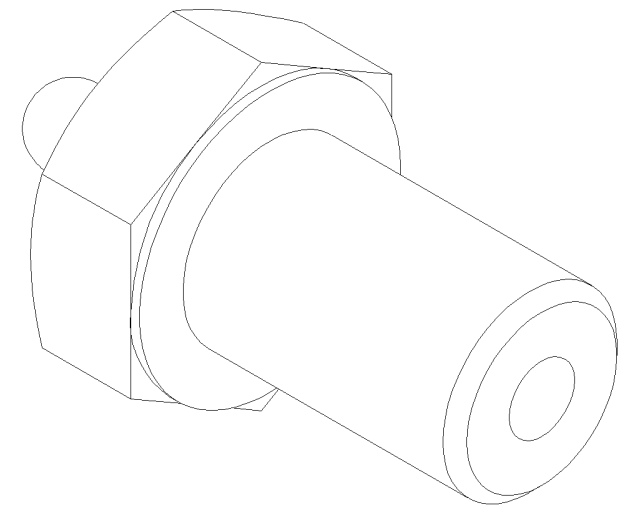
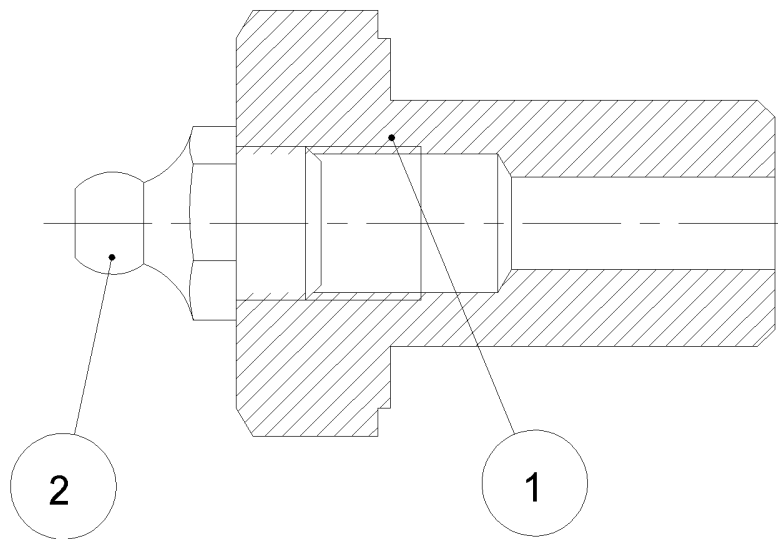

Pos.	Bestell-Nr. Stock Number Numéro de Commande Номер товара	Menge Amount Quantité Количество	Beschreibung	Description	Description	Описание
10	 01.10.16025	1,000	SKT-SCHRAUBE M16X25 8.8	SCREW M16 X 25 MM, DIN933	SCREW M16 X 25 MM, DIN933	
20	 24.A.10.100	1,000	SCHMIERNIPPEL M10X1 GERADE, STAHL	LUBRICATING NIPPLE M10X1	LUBRICATING NIPPLE M10X1	



SCHMIERSCHRAUBE M16X25 M.SCH. - GREASE SCREW M16X25
 GREASE SCREW M16X25 - 01.01.45.16025/A

01.01.45.16025/A
 Stücklistennummer / Piece Number / Liste de Pièces / Номер





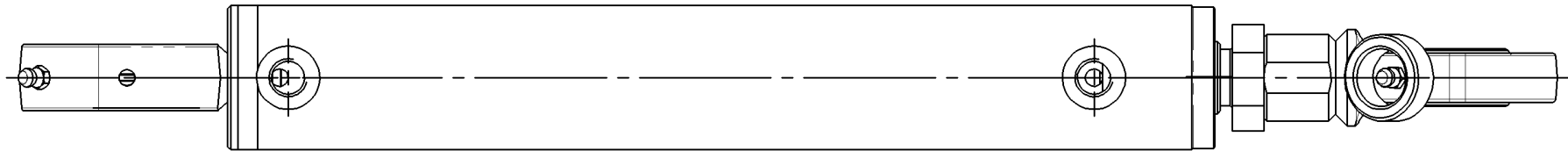

Pos.	Bestell-Nr. Stock Number Numéro de Commande Номер товара	Menge Amount Quantité Количество	Beschreibung	Description	Description	Описание
10	 01.10.16025	1,000	SKT-SCHRAUBE M16X25 8.8	SCREW M16 X 25 MM, DIN933	SCREW M16 X 25 MM, DIN933	
20	 24.A.10.100	1,000	SCHMIERNIPPEL M10X1 GERADE, STAHL	LUBRICATING NIPPLE M10X1	LUBRICATING NIPPLE M10X1	



HYDRAULIK-ZYLINDER - HYDR. CYLINDER
 HYDR. CYLINDER - 991.10.12.00.00/00

991.10.12.00.00/00
 Stücklistennummer / Piece Number / Liste de Pièces / Номер



Pos.		Bestell-Nr. Stock Number Numéro de Commande Номер товара	Menge Amount Quantité Количество	Beschreibung	Description	Description	Описание
10		20.92.025	1,000	GELENKKOPF	GELENKKOPF D25	GELENKKOPF D25	
20		20.92.01.006	1,000	FUEHRUNGSKOPF OHNE DICHTUNGSSATZ	FUEHRUNGSKOPF OHNE DICHTUNGSSATZ	FUEHRUNGSKOPF OHNE DICHTUNGSSATZ	
30		20.91.005.FE	1,000	DICHTUNGSSATZ 40-25 HYDRAULIKZYLINDER	HYDRAULIC CYLINDER GASKET	HYDRAULIC CYLINDER GASKET	

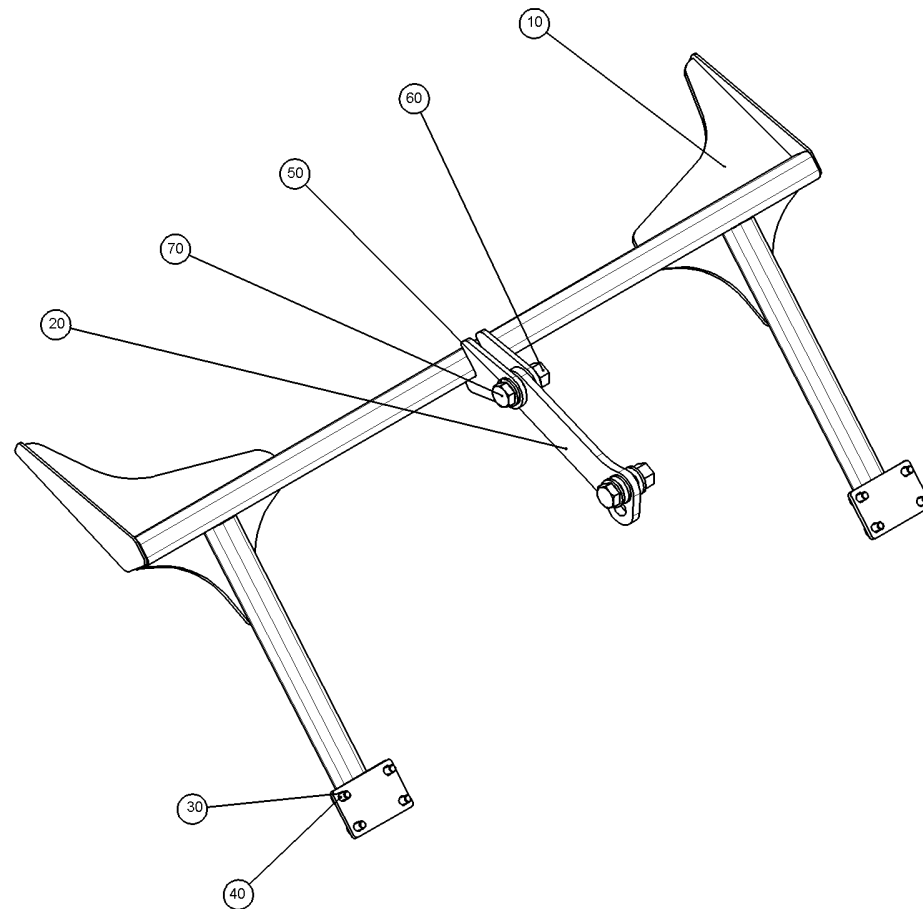









DRUECKEVORRICHTUNG KLAPPENS. KOMPLETT - PUSH-BAR ON FLAP SIDE
 PUSH-BAR ON FLAP SIDE - 470.07.00.00.00/A

470.07.00.00.00/A

Stücklistennummer / Piece Number / Liste de Pièces / Homep



Pos.		Bestell-Nr. Stock Number Numéro de Commande Номер товара	Menge Amount Quantité Количество	Beschreibung	Description	Description	Описание
10		470.07.01.00.00/00	1,000	DRUECKEVORRICHTUNG GESCHWEISST	DRUECKEVORRICHTUNG GESCHWEISST	DRUECKEVORRICHTUNG GESCHWEISST	
20		740.07.00.00.01/00	1,000	ANBINDUNG DRUECKEVORRICHTUNG	PUSH BAR CONECTION	PUSH BAR CONECTION	
30		05.01.10	8,000	SCHEIBE ISO 7090-10-200HV	WASHER B10,5 DIN 125 GALV.	WASHER B10,5 DIN 125 GALV.	
40		01.10.10020	8,000	SKT-SCHRAUBE M10X20 8.8	SCREW M10X20 DIN 933	SCREW M10X20 DIN 933	
50		05.08.21	8,000	SCHEIBE B21	DISC B21 DIN134	DISC B21 DIN134	
60		03.02.20	2,000	SKT-MUTTER M20 8, SELBSTSICH.	NUT M20 DIN980V SELF- LOCKING	NUT M20 DIN980V SELF- LOCKING	
70		01.10.20065	2,000	SKT-SCHRAUBE M20X65 8.8	SCREW M20X65 DIN 933	SCREW M20X65 DIN 933	

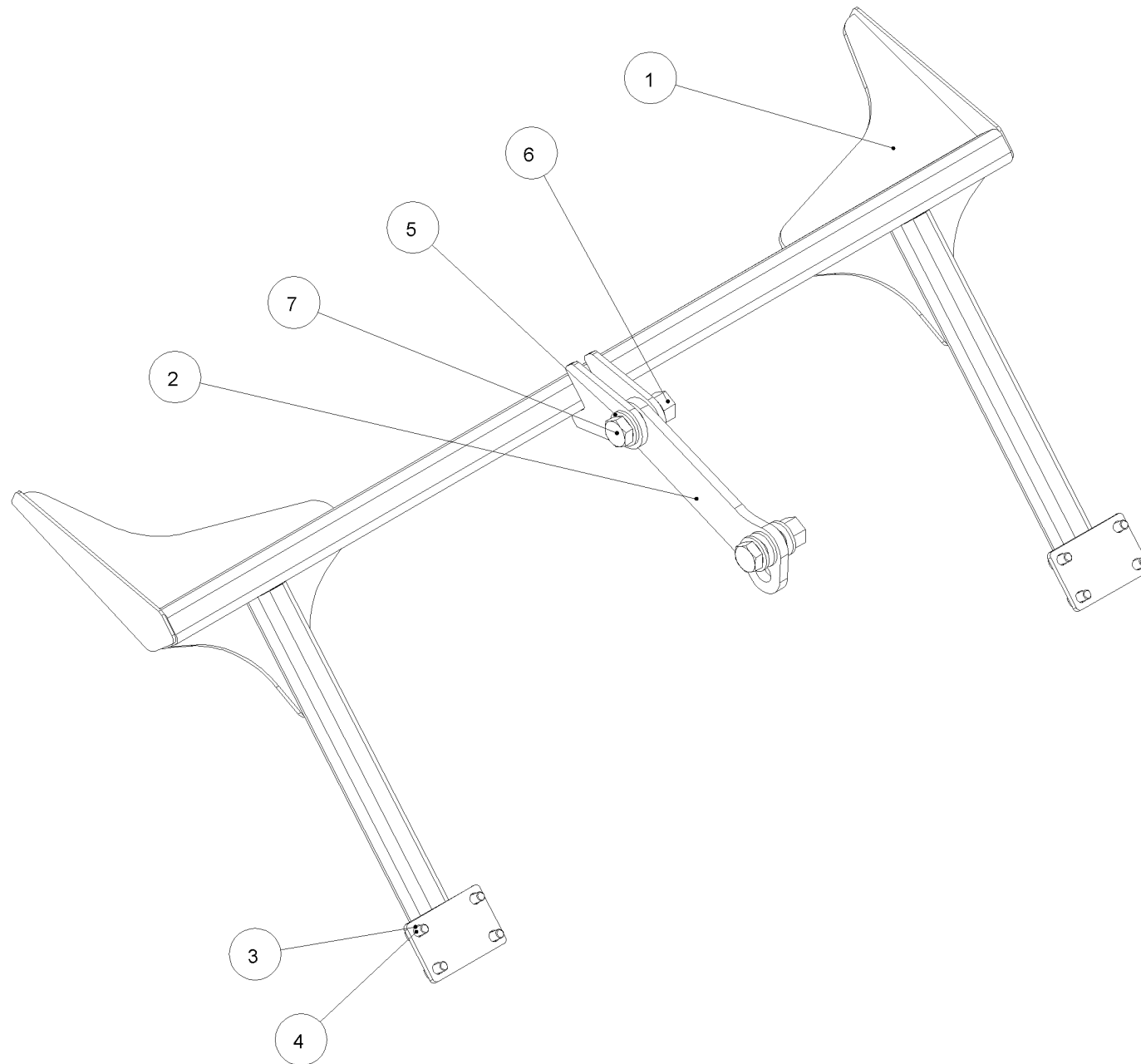









DRUECKEVORRICHTUNG KLAPPENS. KOMPLETT - PUSH-BAR ON FLAP SIDE
 PUSH-BAR ON FLAP SIDE - 470.07.00.00.00/A

470.07.00.00.00/A

Stücklistennummer / Piece Number / Liste de Pièces / Homep



Pos.		Bestell-Nr. Stock Number Numéro de Commande Номер товара	Menge Amount Quantité Количество	Beschreibung	Description	Description	Описание
10		470.07.01.00.00/00	1,000	DRUECKEVORRICHTUNG GESCHWEISST	DRUECKEVORRICHTUNG GESCHWEISST	DRUECKEVORRICHTUNG GESCHWEISST	
20		740.07.00.00.01/00	1,000	ANBINDUNG DRUECKEVORRICHTUNG	PUSH BAR CONECTION	PUSH BAR CONECTION	
30		05.01.10	8,000	SCHEIBE ISO 7090-10-200HV	WASHER B10,5 DIN 125 GALV.	WASHER B10,5 DIN 125 GALV.	
40		01.10.10020	8,000	SKT-SCHRAUBE M10X20 8.8	SCREW M10X20 DIN 933	SCREW M10X20 DIN 933	
50		05.08.21	8,000	SCHEIBE B21	DISC B21 DIN134	DISC B21 DIN134	
60		03.02.20	2,000	SKT-MUTTER M20 8, SELBSTSICH.	NUT M20 DIN980V SELF- LOCKING	NUT M20 DIN980V SELF- LOCKING	
70		01.10.20065	2,000	SKT-SCHRAUBE M20X65 8.8	SCREW M20X65 DIN 933	SCREW M20X65 DIN 933	

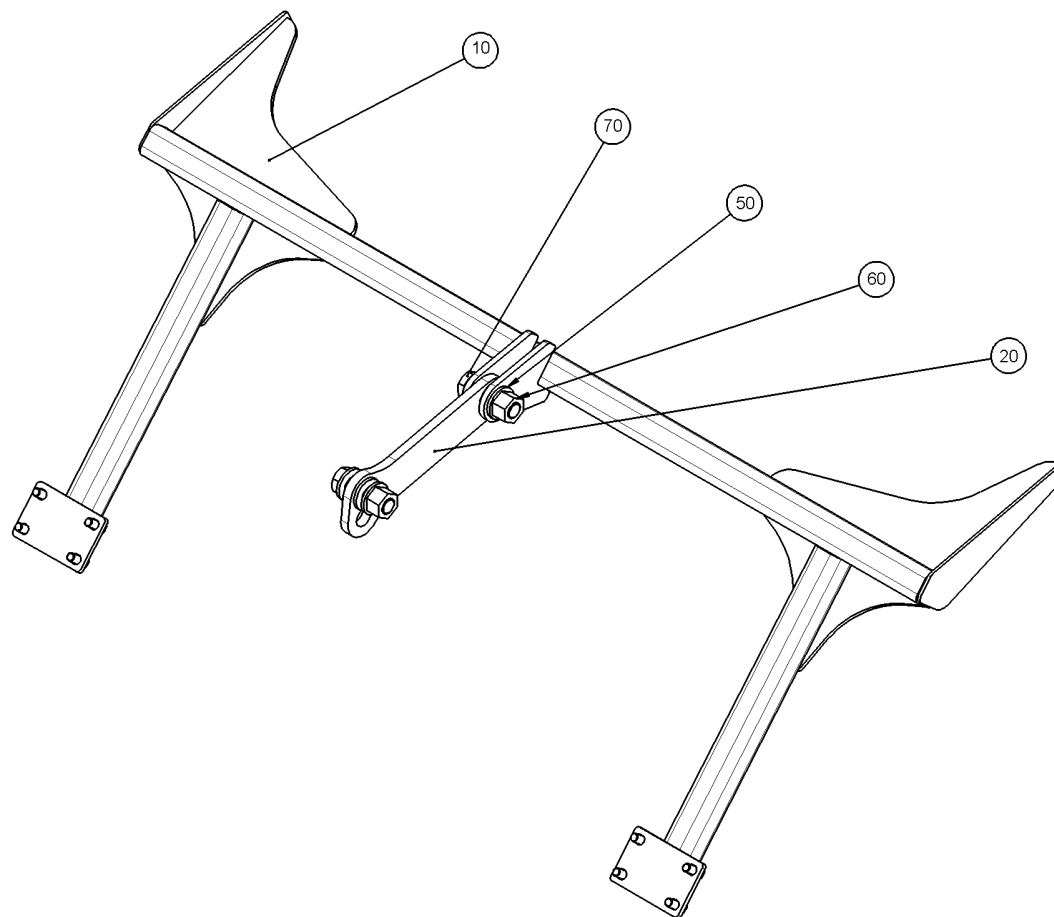
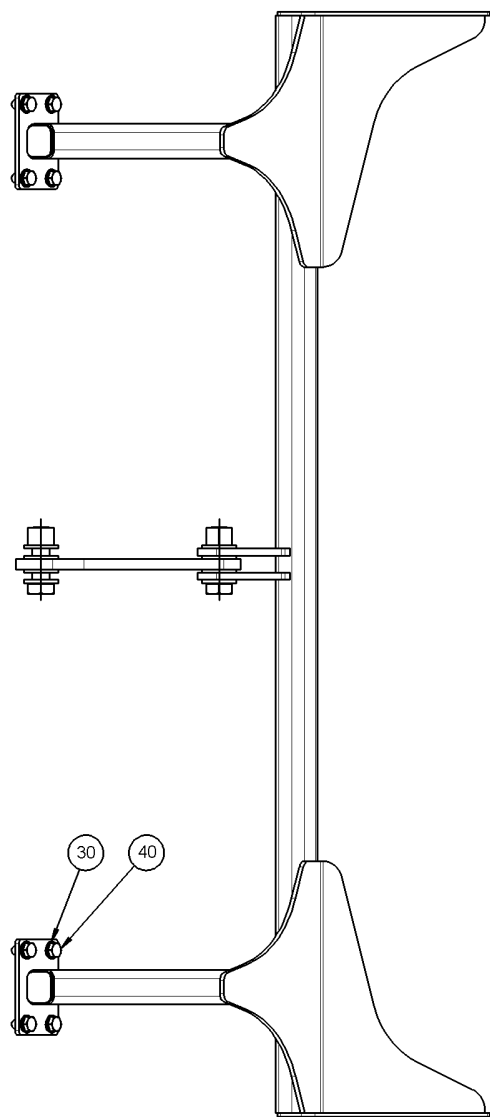









DRUECKEVORRICHTUNG KETTENSEITIG KOMPLETT - PUSH-BAR ON CHAIN GUARD SIDE
 PUSH-BAR ON CHAIN GUARD SIDE - 470.07.00.01.00/00

470.07.00.01.00/00

Stücklistennummer / Piece Number / Liste de Pièces / Homep



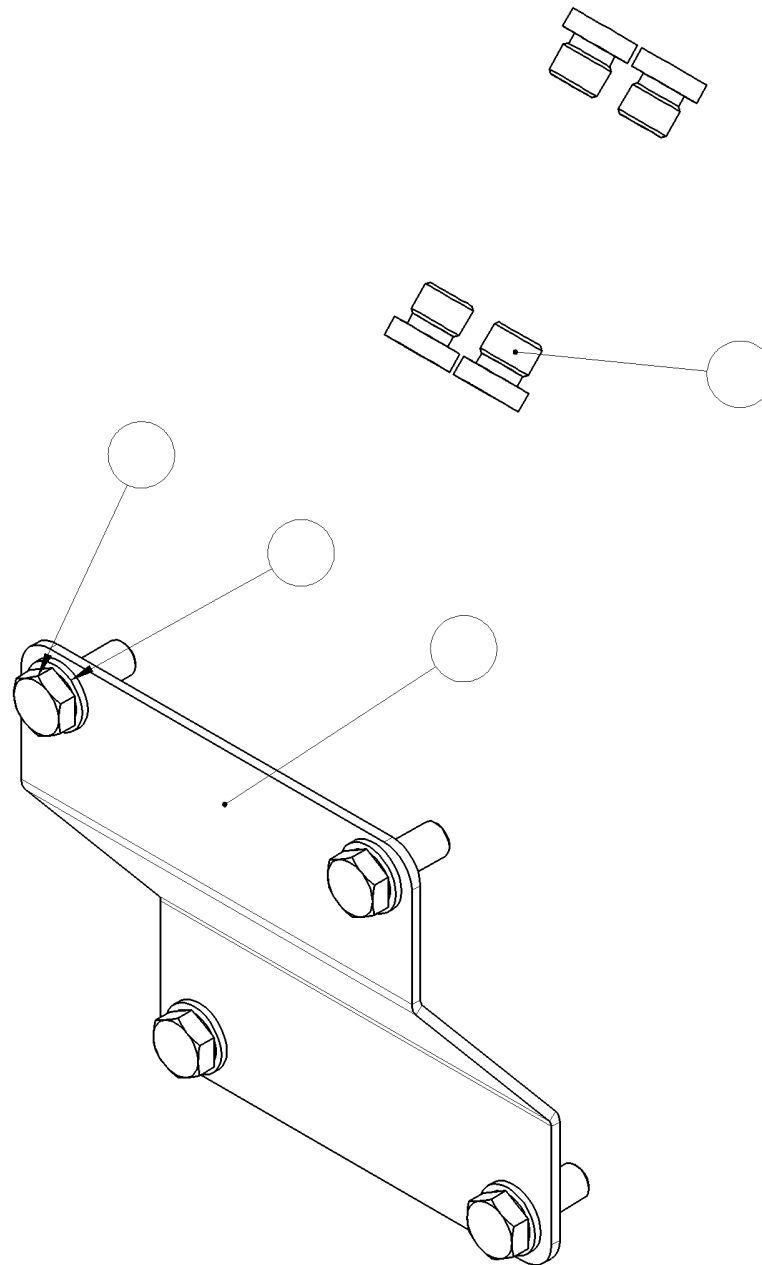

Pos.		Bestell-Nr. Stock Number Numéro de Commande Номер товара	Menge Amount Quantité Количество	Beschreibung	Description	Description	Описание
10		470.07.01.00.00/00	1,000	DRUECKEVORRICHTUNG GESCHWEISST	DRUECKEVORRICHTUNG GESCHWEISST	DRUECKEVORRICHTUNG GESCHWEISST	
20		740.07.00.00.01/00	1,000	ANBINDUNG DRUECKEVORRICHTUNG	PUSH BAR CONECTION	PUSH BAR CONECTION	
30		05.01.10	8,000	SCHEIBE ISO 7090-10-200HV	WASHER B10,5 DIN 125 GALV.	WASHER B10,5 DIN 125 GALV.	
40		01.10.10020	8,000	SKT-SCHRAUBE M10X20 8.8	SCREW M10X20 DIN 933	SCREW M10X20 DIN 933	
50		05.08.21	8,000	SCHEIBE B21	DISC B21 DIN134	DISC B21 DIN134	
60		03.02.20	2,000	SKT-MUTTER M20 8, SELBSTSICH.	NUT M20 DIN980V SELF- LOCKING	NUT M20 DIN980V SELF- LOCKING	
70		01.10.20065	2,000	SKT-SCHRAUBE M20X65 8.8	SCREW M20X65 DIN 933	SCREW M20X65 DIN 933	



DECKEL WENN OHNE Klappe - DECKEL WENN OHNE Klappe
 DECKEL WENN OHNE Klappe - 470.10.03.00.00/00

470.10.03.00.00/00
 Stücklistennummer / Piece Number / Liste de Pièces / Номер



Pos.		Bestell-Nr. Stock Number Numéro de Commande Номер товара	Menge Amount Quantité Количество	Beschreibung	Description	Description	Описание
10		470.10.03.00.01/00	1,000	BLECH	BLECH	BLECH	
20		20.VS14.1.5/00	4,000	VERSCHLUSSSCHRAUBE M14X1,5 PN400, I-SW6	LOCK SCREW M14X1,5	LOCK SCREW M14X1,5	
30		05.01.10	4,000	SCHEIBE ISO 7090-10-200HV	WASHER B10,5 DIN 125 GALV.	WASHER B10,5 DIN 125 GALV.	
40		01.10.10025	4,000	SKT-SCHRAUBE M10X25 8.8	SCREW M10X25 DIN 933	SCREW M10X25 DIN 933	

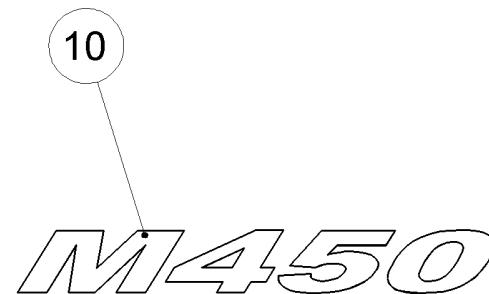
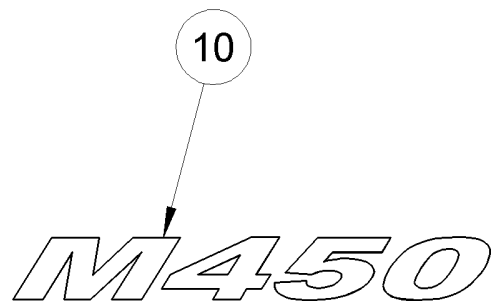

•
•
•
•

Pos.	Bestell-Nr. Stock Number Numéro de Commande Номер товара	Menge Amount Quantité Количество	Beschreibung	Description	Description	Описание
10	<i>M450</i> 85.01.109/00	2,000	AUFKLEBER M450	AUFKLEBER M450	AUFKLEBER M450	
20	41233326/03	1,000	PRODUKTGRAFIK- MULCHGERAET	PRODUCT GRAPHICS-MULCHER	GRAPHIQUE DU PRODUIT- BROYEUR	
30	 85.01.33/A	1,000	AUFKLEBER D50 PRUEFPLAKETTE GRUEN	LABEL	LABEL	

Pos.	Bestell-Nr. Stock Number Numéro de Commande Номер товара	Menge Amount Quantité Количество	Beschreibung	Description	Description	Описание
1	 85.01.138/01	1,000	AUFKLEBER- VERDREHSICHERUNG	STICKER-ANTI ROTATION PROTECTION	AUTOCOLLANT-PROTECTION ANTIROTATION	
2	 85.01.148/01	1,000	AUFKLEBER- VERDREHSICHERUNG	STICKER-ANTI ROTATION PROTECTION	AUTOCOLLANT-PROTECTION ANTIROTATION	
3	 85.01.21/00	1,000	GEFAHRENAUFKLEBER 1000 U/ MIN	DANGER STICKER 1000 U/MIN	DANGER STICKER 1000 U/MIN	
4	 85.01.13/00	1,000	GEFAHRENAUFKLEBER ROTIERENDES WERKZEUG	DANGER STICKER ROTATING TOOLS	DANGER STICKER ROTATING TOOLS	
5	 85.01.28/00	1,000	GEFAHRENAUFKLEBER SCHLUESSEL	DANGER STICKER KEY	DANGER STICKER KEY	
6	 85.01.17/00	2,000	GEFAHRENAUFKLEBER STEINFLUG	DANGER STICKER FLYING STONES	DANGER STICKER FLYING STONES	
7	 85.01.22/00	1,000	GEFAHRENAUFKLEBER BETRIEBSANLEITUNG	DANGER STICKER OPERATING INSTR	DANGER STICKER OPERATING INSTR	
8	 85.01.27/00	1,000	GEFAHRENAUFKLEBER MASCHINE AUS	DANGER STICKER MACHINE OFF	DANGER STICKER MACHINE OFF	
9	85.01.20/00	1,000	GEFAHRENAUFKLEBER 1300 U/ MIN	DANGER LABEL	DANGER LABEL	

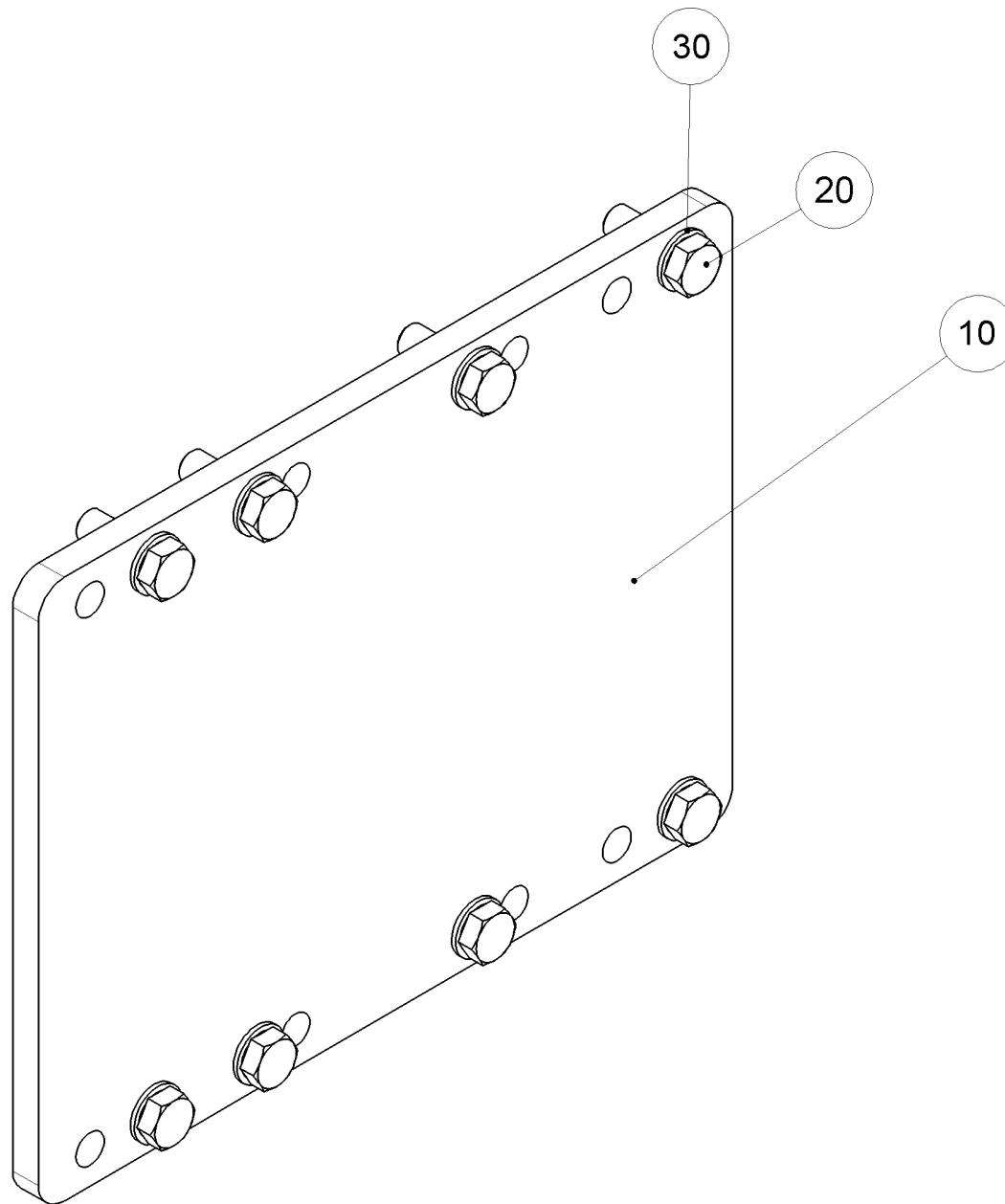





ADAPTERPLATTE GESCHRAUBT - INTERFACE
INTERFACE - 470.32.01.00.00/00

470.32.01.00.00/00
Stücklistennummer / Piece Number / Liste de Pièces / Номер



Pos.		Bestell-Nr. Stock Number Numéro de Commande Номер товара	Menge Amount Quantité Количество	Beschreibung	Description	Description	Описание
10		470.32.01.00.01/01	1,000	ADAPTER-PLATTE	ADAPTOR-PLATE	ADAPTATEUR-PLAQUE	
20		01.10.20055	8,000	SKT-SCHRAUBE M20X55 8.8	SCREW M20X55 DIN 933	SCREW M20X55 DIN 933	
30		05.01.21	8,000	SCHEIBE ISO 7090-21-200HV	WASHER B21 DIN 125 GALVANIZED	WASHER B21 DIN 125 GALVANIZED	

	PRINOTH GmbH D-88634 Herdwangen Im Branden 15
Maschinenbezeichnung:	<input type="text"/>
Maschinentyp:	<input type="text"/>
Seriennummer:	<input type="text"/>
Artikelnummer:	<input type="text"/>
Gesamtgewicht:	<input type="text"/>
Baujahr:	<input type="text"/>
 Made in Germany	www.prinoth.com   



1

2









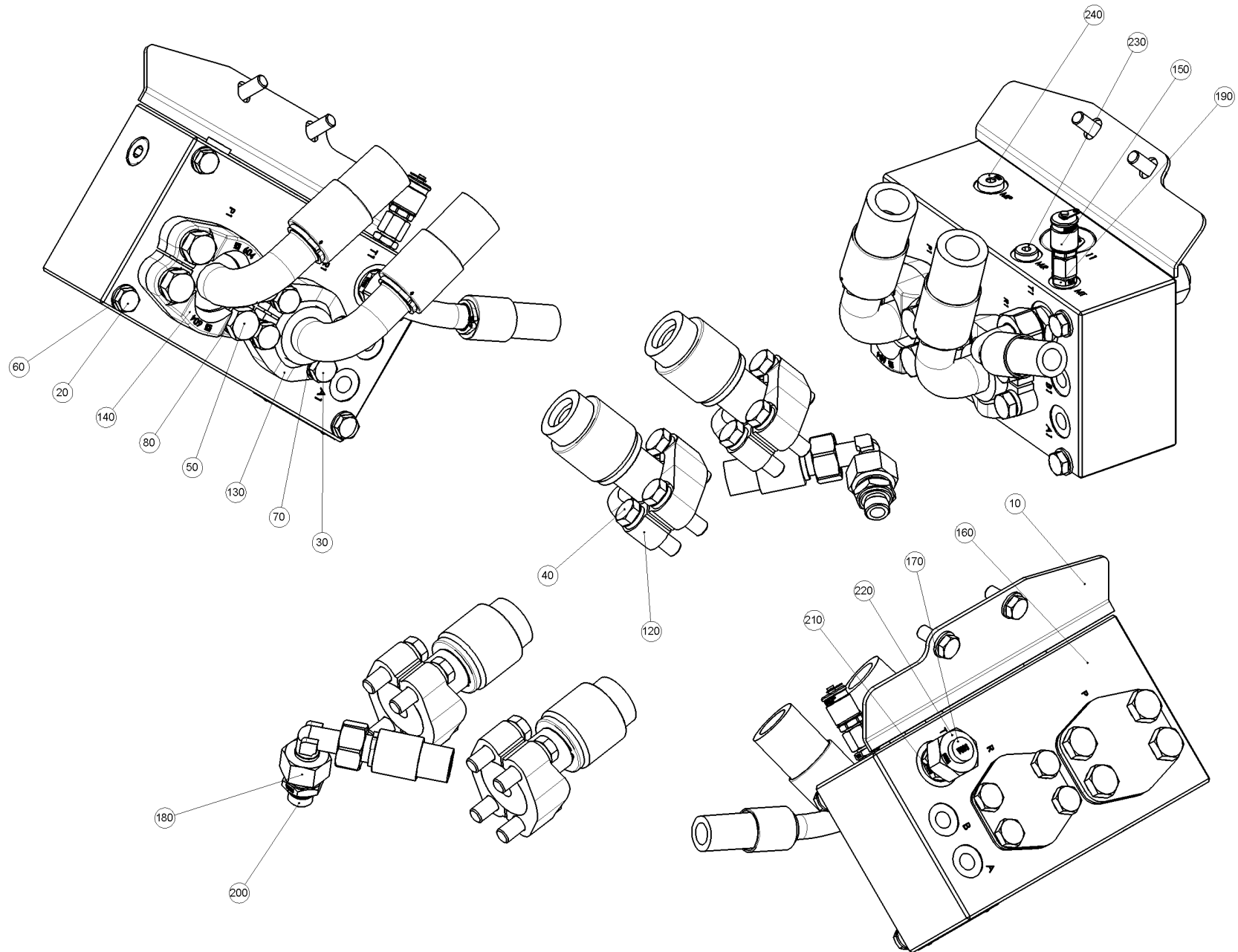



TYPENSCHILD + NIETEN - TYPENSCHILD + NIETEN
TYPENSCHILD + NIETEN - 551.01.00.90.00/00

551.01.00.90.00/00
Stücklistennummer / Piece Number / Liste de Pièces / Номер





Pos.		Bestell-Nr. Stock Number Numéro de Commande Номер товара	Menge Amount Quantité Количество	Beschreibung	Description	Description	Описание
10		85.003.001/04	1,000	TYPENSCHILD-CE KENNZEICHNUNG	IDENTIFICATION PLATE-CE MARKING	PLAQUE SIGNALETIQUE- MARQUAGE CE	
20		84.110.03.12/00	4,000	BLINDNIETE 3,2X12 KLEMMB. 7-9,FLACHK.	BLIND RIVET	BLIND RIVET	

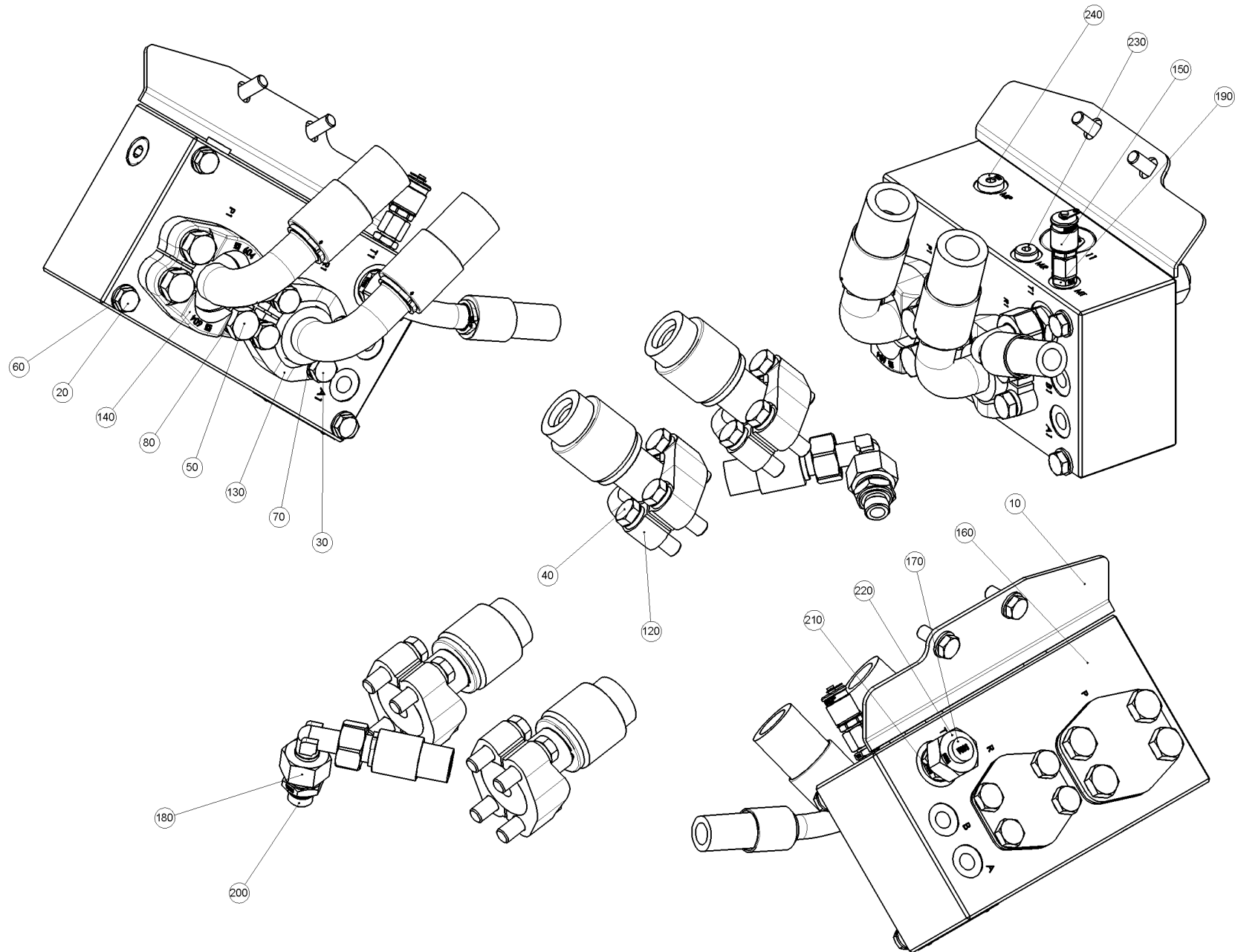

Pos.		Bestell-Nr. Stock Number Numéro de Commande Номер товара	Menge Amount Quantité Количество	Beschreibung	Description	Description	Описание
10		470.01.20.00.00/00	1,000	DECKEL ANSCHLUSSBLOCK	DECKEL ANSCHLUSSBLOCK	DECKEL ANSCHLUSSBLOCK	
20		01.10.10020	4,000	SKT-SCHRAUBE M10X20 8.8	SCREW M10X20 DIN 933	SCREW M10X20 DIN 933	
40		01.10.12045.C.V	8,000	SKT-SCHRAUBE M12X45 10.9	SCREW M12X45	SCREW M12X45	
50		01.10.14050.C	4,000	SKT-SCHRAUBE M14X50 10.9 VERGUETET	SKT-SCHRAUBE M14X50 10.9 VERGUETET	SKT-SCHRAUBE M14X50 10.9 VERGUETET	
60		05.01.10	4,000	SCHEIBE ISO 7090-10-200HV	WASHER B10,5 DIN 125 GALV.	WASHER B10,5 DIN 125 GALV.	
70		07.02.12	12,0- 00	NORD-LOCK-SCHEIBE FUER M12	NORD-LOCK-DISC FOR M12	NORD-LOCK-DISC FOR M12	
80		07.02.14	4,000	NORD-LOCK-SCHEIBE FUER M14	NORD-LOCK-DISC FOR M14	NORD-LOCK-DISC FOR M14	
90		20.02.00576/00	1,000	HYDRAULIKSCHLAUCH	HYDRAULIC HOSE	BOYAU HYDRAULIQUE	
100		20.02.00578/00	1,000	HYDRAULIKSCHLAUCH	HYDRAULIC HOSE	BOYAU HYDRAULIQUE	
110		20.02.14.18.0800.B/00	1,000	HYDRAULIKSCHLAUCH	HYDRAULIC HOSE	BOYAU HYDRAULIQUE	
120		20.29.001/00	2,000	SAE-HALBFLANSCH 1 6000 PSI	SAE-HALF FLANGE 1"	SAE-HALF FLANGE 1"	



Pos.		Bestell-Nr. Stock Number Numéro de Commande Номер товара	Menge Amount Quantité Количество	Beschreibung	Description	Description	Описание
130		20.29.002/00	1,000	SAE-HALBFLANSCH 1 1/4 3000 PSI M12	SAE-HALF FLANGE 1 1/4"	SAE-HALF FLANGE 1 1/4"	
140		20.29.005/A	1,000	SAE-HALBFLANSCH 1 1/4 6000 PSI	SAE-HALBFLANSCH 1 1/4 6000 PSI	SAE-HALBFLANSCH 1 1/4 6000 PSI	
150		20.41.001/00	1,000	PRUEFANSCHLUSS MINIMESS 8L SMK 20	FITTING MEASUREMENT 8L/ SMK20	FITTING MEASUREMENT 8L/ SMK20	
160		20.60.045/A	1,000	ANSCHLUSSBLOCK	ANSCHLUSSBLOCK	ANSCHLUSSBLOCK	
170		20.BUZ18L/00	1,000	VERSCHLUSSTOPFEN 18L PN400 SW32	FITTING FOR MEASURE 18L C/ NUT	FITTING FOR MEASURE 18L C/ NUT	
180		20.EWV18L/00	1,000	EINSTELLBARE-VERSCHR. EW 18L PN400	HYDR. FITTING EWV 18L	HYDR. FITTING EWV 18L	
190		20.GEV08L.M12-1.5/00	1,000	GER-EINSCHR-VERSCHR. 8L	MALE STUD COUPLING 08L M12-1.5	MALE STUD COUPLING 08L M12-1.5	
200		20.GEV18L.M18-1.5/00	1,000	GER-EINSCHR-VERSCHR. 18L	STRAIGHT TUBE FITT. 18L18X1,5	STRAIGHT TUBE FITT. 18L18X1,5	
210		20.GEV18L.M22-1.5/00	2,000	GER-EINSCHR-VERSCHR. 18L	STRAIGHT SCREW FIT. 18L 22X1,5	STRAIGHT SCREW FIT. 18L 22X1,5	
220		20.UEM18L/00	1,000	UEBERWURFMUTTER 18L M26X1,5 PN400, SW32	UNION NUT 18L M26-1.5	UNION NUT 18L M26-1.5	
230		20.VS12.1.5/00	1,000	VERSCHLUSSSCHRAUBE M12X1,5 PN400, I-SW6	LOCK SCREW M12X1,5	LOCK SCREW M12X1,5	

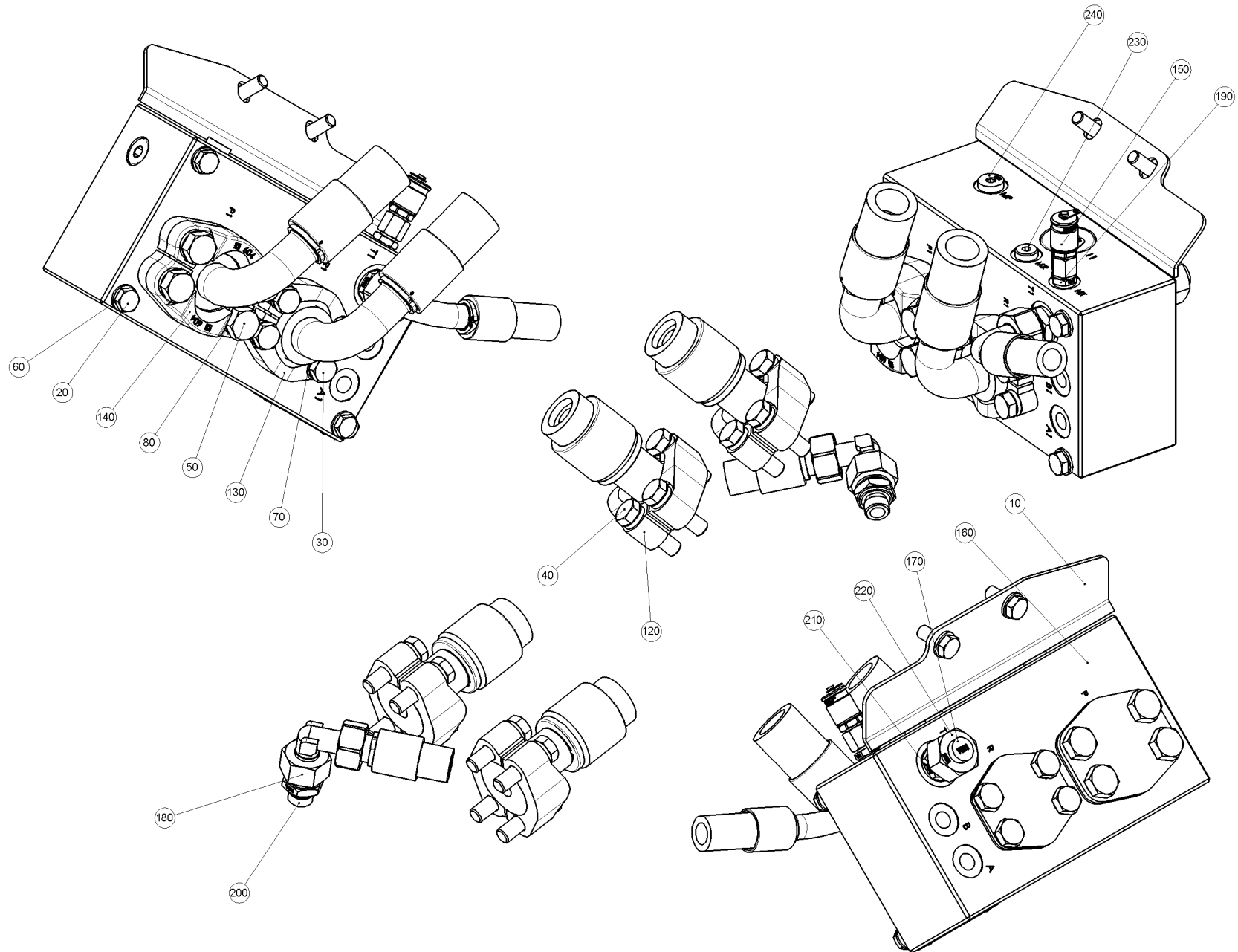

Pos.	Bestell-Nr. Stock Number Numéro de Commande Номер товара	Menge Amount Quantité Количество	Beschreibung	Description	Description	Описание
------	---	---	--------------	-------------	-------------	----------

240	 20.VS14.1.5/00	1,000	VERSCHLUSSSCHRAUBE M14X1,5 PN400, I-SW6	LOCK SCREW M14X1,5	LOCK SCREW M14X1,5	
-----	--	-------	--	--------------------	--------------------	--

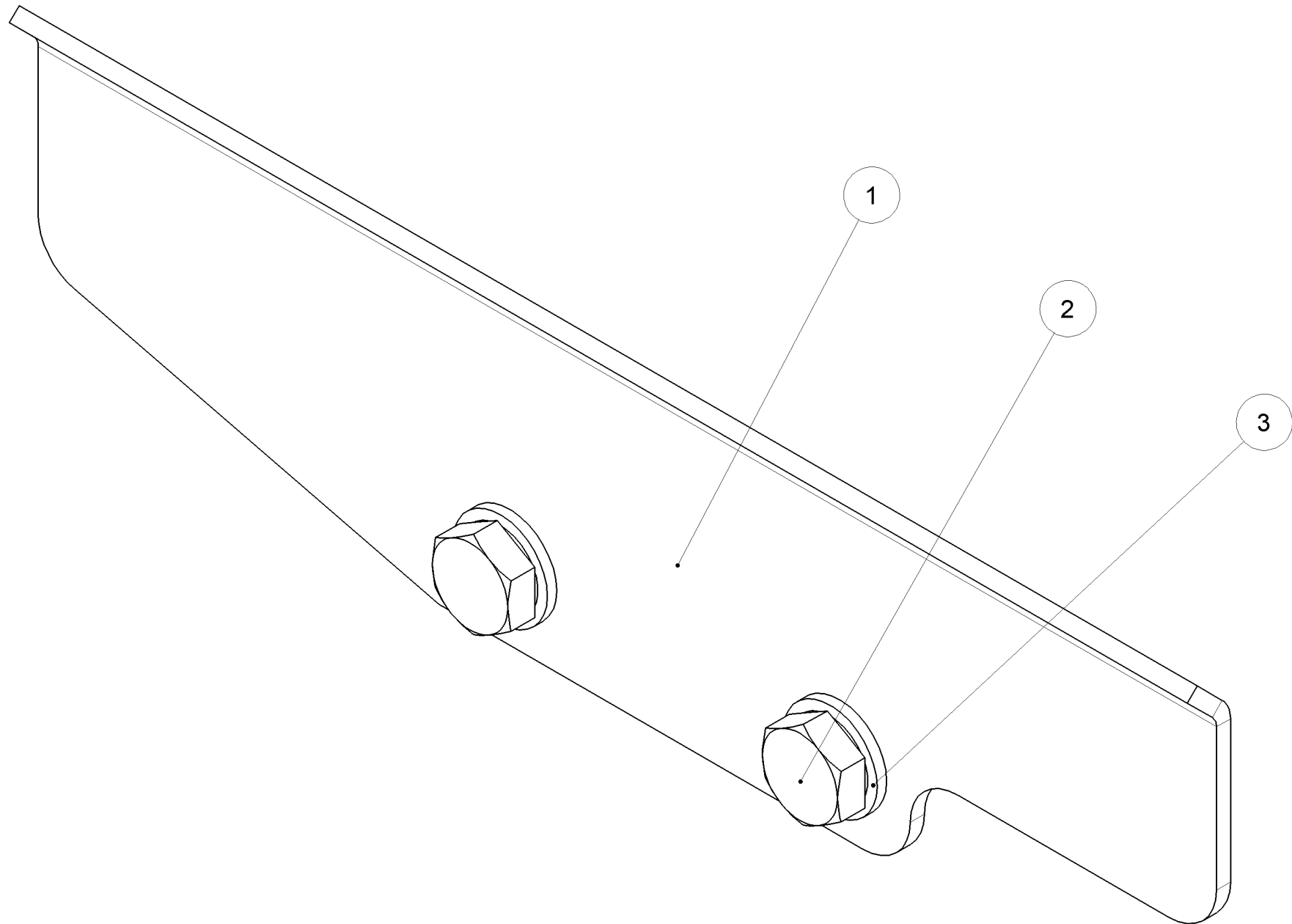

DECKEL ANSCHLUSSBLOCK - DECKEL ANSCHLUSSBLOCK
 DECKEL ANSCHLUSSBLOCK - 470.01.20.00.00/00

470.01.20.00.00/00
 Stücklistennummer / Piece Number / Liste de Pièces / Номер





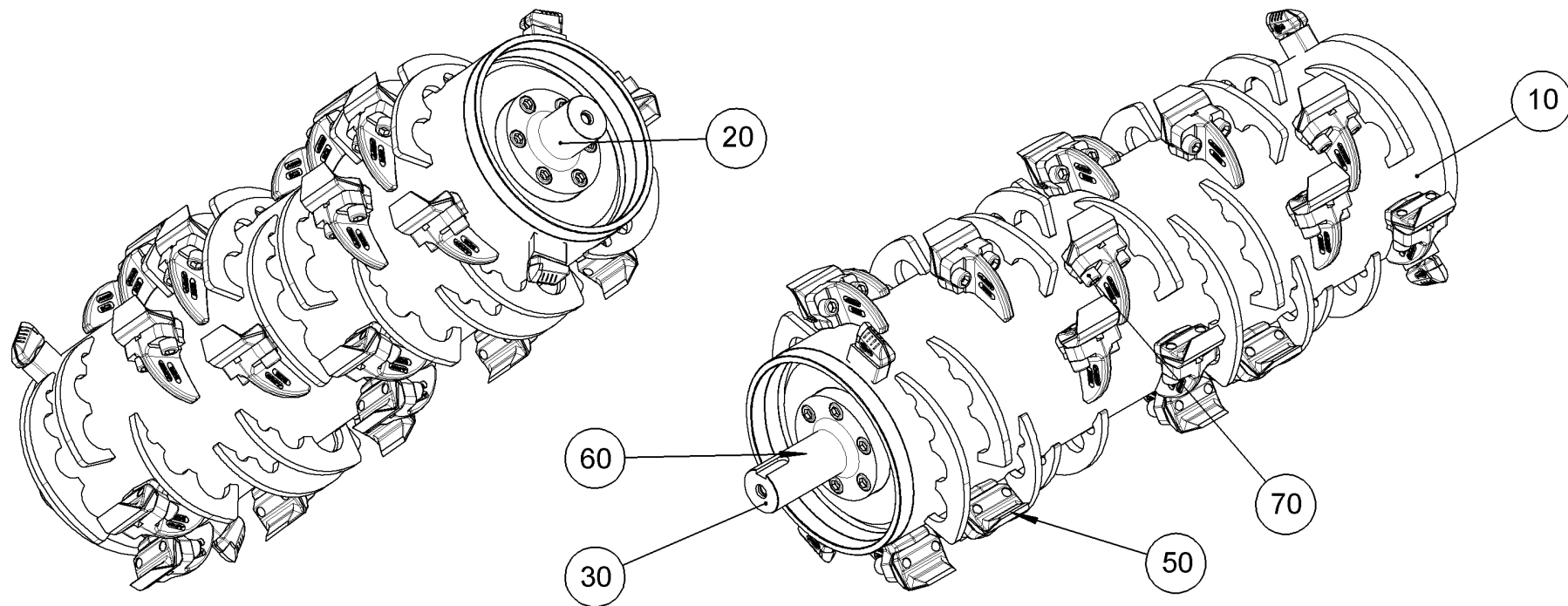



Pos.		Bestell-Nr. Stock Number Numéro de Commande Номер товара	Menge Amount Quantité Количество	Beschreibung	Description	Description	Описание
10		470.01.20.00.01/00	1,000	DECKEL ANSCHLUSSBLOCK	DECKEL ANSCHLUSSBLOCK	DECKEL ANSCHLUSSBLOCK	
20		01.10.10025	2,000	SKT-SCHRAUBE M10X25 8.8	SCREW M10X25 DIN 933	SCREW M10X25 DIN 933	
30		05.01.10	2,000	SCHEIBE ISO 7090-10-200HV	WASHER B10,5 DIN 125 GALV.	WASHER B10,5 DIN 125 GALV.	



ROTOR D450 1100 24XBCS - ROTOR D450 1100 24XBCS
 ROTOR D450 1100 24XBCS - 857.03.00.67.00/B

857.03.00.67.00/B
 Stücklistennummer / Piece Number / Liste de Pièces / Номер





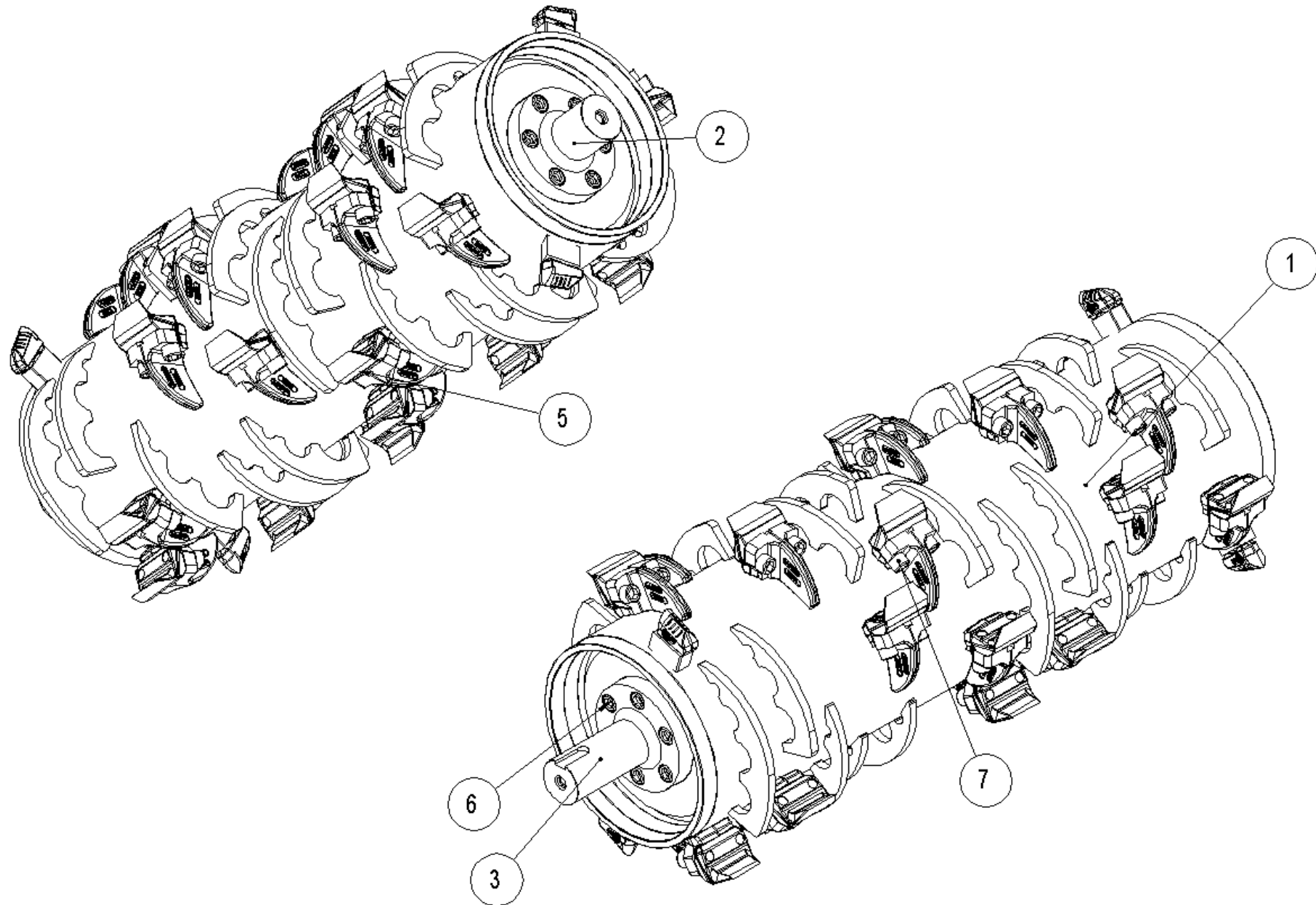



Pos.		Bestell-Nr. Stock Number Numéro de Commande Номер товара	Menge Amount Quantité Количество	Beschreibung	Description	Description	Описание
10		857.03.01.67.00/03	1,000	<u>ROTOR-GESCHWEISST</u>	ROTOR-WELDED	ROTOR-SOUDE	
20		740.03.00.00.01/01	1,000	<u>ROTORSTUMMEL KURZ</u>	ROTOR SHOFT	ROTOR SHOFT	
30		754.03.00.00.01/I	1,000	ROTORWELLENSTUMMEL D65	ROTOR SHAFT STUB FM500	ROTOR SHAFT STUB FM500	
50		01.21.16050.C	12,0- 00	ZYLINDERSCHRAUBE M16X50	SCREW M16X50 DIN6912	SCREW M16X50 DIN6912	
60		01.20.16040.C	48,0- 00	ZYLINDERSCHRAUBE M16X40 10.9 VERGUETET	CYL. HEAD SCREW M16X40 DIN 912	CYL. HEAD SCREW M16X40 DIN 912	
100		46.BCS02/00	24,0- 00	WERKZEUG BCS02	TOOL BCS02	OUTIL BCS02	



ROTOR D450 1100 24XBCS - ROTOR D450 1100 24XBCS
 ROTOR D450 1100 24XBCS - 857.03.00.67.00/B

857.03.00.67.00/B
 Stücklistennummer / Piece Number / Liste de Pièces / Номер



Pos.		Bestell-Nr. Stock Number Numéro de Commande Номер товара	Menge Amount Quantité Количество	Beschreibung	Description	Description	Описание
10		857.03.01.67.00/03	1,000	ROTOR-GESCHWEISST	ROTOR-WELDED	ROTOR-SOUDE	
20		740.03.00.00.01/01	1,000	ROTORSTUMMEL KURZ	ROTOR SHOFT	ROTOR SHOFT	
30		754.03.00.00.01/I	1,000	ROTORWELLENSTUMMEL D65	ROTOR SHAFT STUB FM500	ROTOR SHAFT STUB FM500	
50		01.21.16050.C	12,0- 00	ZYLINDERSCHRAUBE M16X50	SCREW M16X50 DIN6912	SCREW M16X50 DIN6912	
60		01.20.16040.C	48,0- 00	ZYLINDERSCHRAUBE M16X40 10.9 VERGUETET	CYL. HEAD SCREW M16X40 DIN 912	CYL. HEAD SCREW M16X40 DIN 912	
100		46.BCS02/00	24,0- 00	WERKZEUG BCS02	TOOL BCS02	OUTIL BCS02	

ROTOR-GESCHWEISST - ROTOR-WELDED
ROTOR-SOUDE - 857.03.01.67.00/03



857.03.01.67.00/03
Stücklistennummer / Piece Number / Liste de Pièces / Homep



ROTOR-GESCHWEISST - ROTOR-WELDED
 ROTOR-SOUDE - 857.03.01.67.00/03

857.03.01.67.00/03
 Stücklistennummer / Piece Number / Liste de Pièces / Номер



Pos.		Bestell-Nr. Stock Number Numéro de Commande Номер товара	Menge Amount Quantité Количество	Beschreibung	Description	Description	Описание
5		857.03.03.28.02/00	4,000	VERSCHLEISSSCHUTZ	WEAR PROTECTION	WEAR PROTECTION	
6		46.BCS01/01	24,0-00	WERKZEUG-HALTER BCS01	TOOL-SUPPORT BCS01	OUTIL-SUPPORT BCS01	

ROTORSTUMMEL KURZ - ROTOR SHOFT
ROTOR SHOFT - 740.03.00.00.01/01

740.03.00.00.01/01
Stücklistennummer / Piece Number / Liste de Pièces / Homep



ROTORSTUMMEL KURZ - ROTOR SHOFT
ROTOR SHOFT - 740.03.00.00.01/01







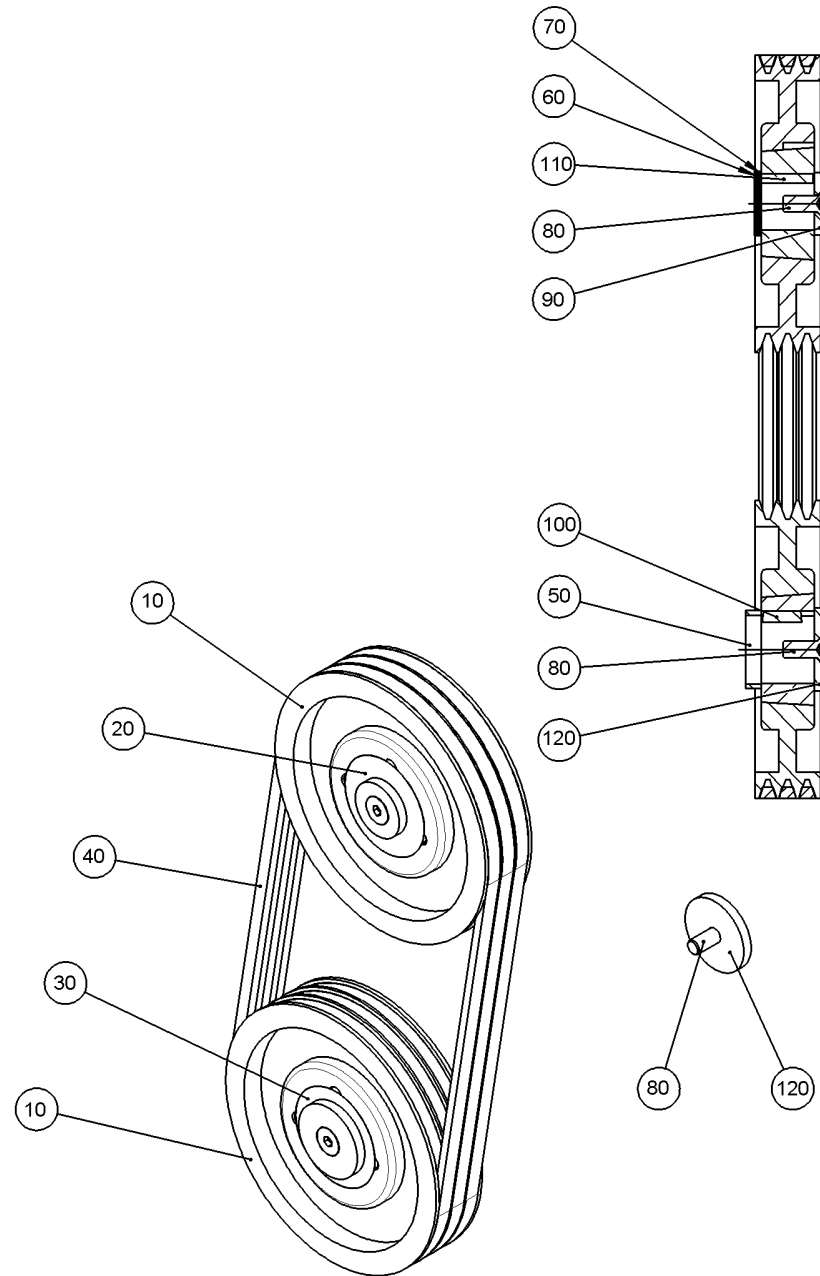

740.03.00.00.01/01
Stücklistennummer / Piece Number / Liste de Pièces / Номер



Pos.	Bestell-Nr. Stock Number Numéro de Commande Номер товара	Menge Amount Quantité Количество	Beschreibung	Description	Description	Описание
------	---	---	--------------	-------------	-------------	----------

1	 740.03.00.00.01/01	1,000	ROTORWELLENSTUMMEL D65	ROTOR SHAFT STUB FM500	ROTOR SHAFT STUB FM500	
---	--	-------	------------------------	------------------------	------------------------	--



Pos.		Bestell-Nr. Stock Number Numéro de Commande Номер товара	Menge Amount Quantité Количество	Beschreibung	Description	Description	Описание
10		48.01.280.3/00	2,000	KEILRIEMENSCHLEIBE SPB 280X3 TL 3020 KM	V-BELT PULLEY SPB 280X3	V-BELT PULLEY SPB 280X3	
20		49.50.3020/00	1,000	<u>TAPERLOCK 3020 D50</u>	TAPERLOCK-BUSHING D 50 /3020	TAPERLOCK-BUSHING D 50 /3020	
30		49.65.3020/00	1,000	<u>TAPERLOCK 3020 D65</u>	TAPERLOCK-BUSHING D 65 /3020	TAPERLOCK-BUSHING D 65 /3020	
40		450.02.03.10.00/00	1,000	<u>KEILRIEMENSATZ KEILRIEMEN B17 1700 LW</u>	POWERBELT SET	POWERBELT SET	
50		451.02.04.02.01/00	1,000	DISTANZRING D75X4,5X15	SPACER RING	SPACER RING	
60		100275	2,000	PASSSCHEIBE 50X62X2	ADJUSTING WASHER	ADJUSTING WASHER	
70		18.050.062.1	3,000	PASSSCHEIBE 50X62X1 GEOELT	SPACER	SPACER	
80		01.30.16040.C.V	3,000	SENKSCHRAUBE M16X40 10.9	COUNTERSUNK HEAD SCREW M16X40	COUNTERSUNK HEAD SCREW M16X40	
90		05.10.060.17.0.J1	1,000	SCHEIBE 60XD17X10 GESENKT	WASHER 60XD17X10	WASHER 60XD17X10	
100		09.18.11.40	1,000	PASSFEDER 18X11X40 FORM A	FITTED KEY 18X11X40 DIN6885	FITTED KEY 18X11X40 DIN6885	
110		09.14.09.50	1,000	PASSFEDER 14X9X50 FORM A	SPRING 14 X 9 X 50 DIN6885	SPRING 14 X 9 X 50 DIN6885	

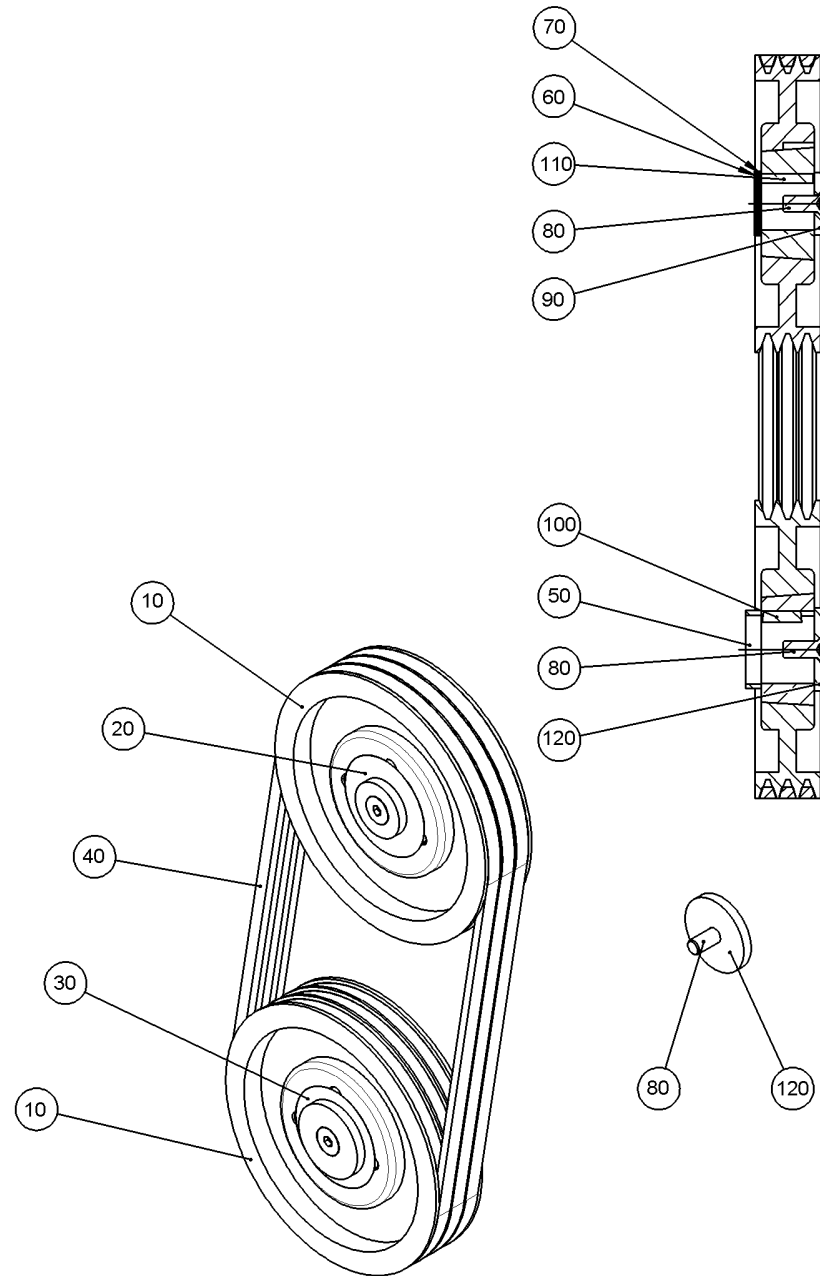

RIEMENUEBERSETZUNG I=1,0 - RIEMENUEBERSETZUNG I=1,0
RIEMENUEBERSETZUNG I=1,0 - 470.02.04.01.00/00

470.02.04.01.00/00
Stücklistennummer / Piece Number / Liste de Pièces / Номер



Pos.	Bestell-Nr. Stock Number Numéro de Commande Номер товара	Menge Amount Quantité Количество	Beschreibung	Description	Description	Описание
120	 05.10.080.16.5.J1	2,000	SCHEIBE 80XD16,5X10 GESENKT	WASHER 80 X 16,5 D, 10 THICK	WASHER 80 X 16,5 D, 10 THICK	

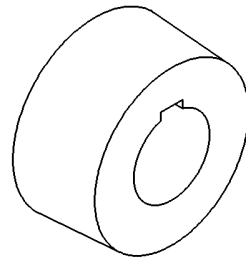

TAPERLOCK 3020 D50 - TAPERLOCK-BUSHING D 50 /3020
TAPERLOCK-BUSHING D 50 /3020 - 49.50.3020/00

49.50.3020/00

Stücklistennummer / Piece Number / Liste de Pièces / Номер



Pos.	Bestell-Nr. Stock Number Numéro de Commande Номер товара	Menge Amount Quantité Количество	Beschreibung	Description	Description	Описание
------	---	---	--------------	-------------	-------------	----------

10	49.1.3020	2,000	INBUSSCHRAUBE	SOCKET SCREW	SOCKET SCREW	
----	-----------	-------	---------------	--------------	--------------	--

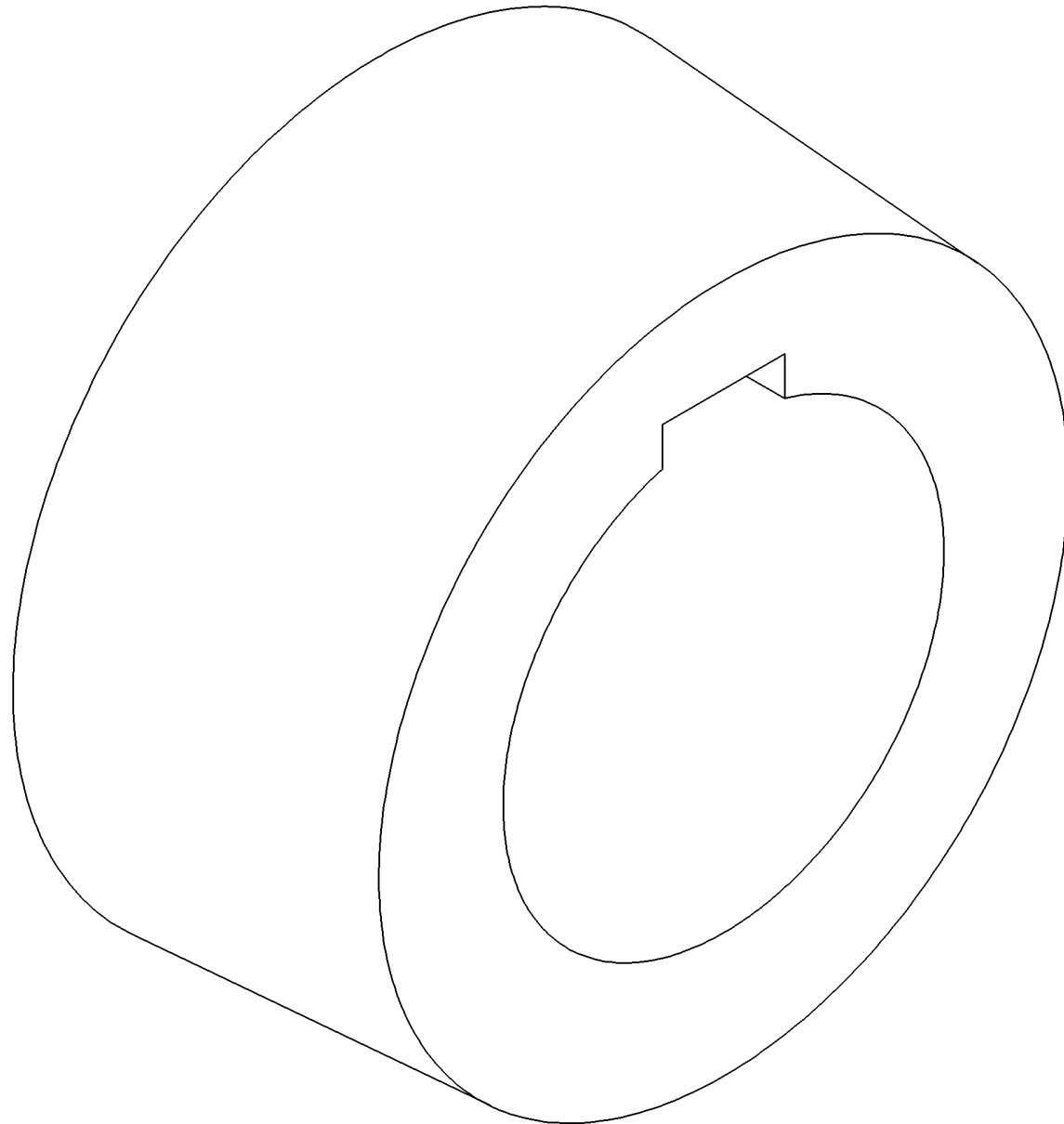

TAPERLOCK 3020 D65 - TAPERLOCK-BUSHING D 65 /3020
TAPERLOCK-BUSHING D 65 /3020 - 49.65.3020/00

49.65.3020/00

Stücklistennummer / Piece Number / Liste de Pièces / Номер



Pos.	Bestell-Nr. Stock Number Numéro de Commande Номер товара	Menge Amount Quantité Количество	Beschreibung	Description	Description	Описание
------	---	---	--------------	-------------	-------------	----------

10	49.1.3020	2,000	INBUSSCHRAUBE	SOCKET SCREW	SOCKET SCREW	
----	-----------	-------	---------------	--------------	--------------	--

KEILRIEMENSATZ KEILRIEMEN B17 1700 LW - POWERBELT SET
POWERBELT SET - 450.02.03.10.00/00









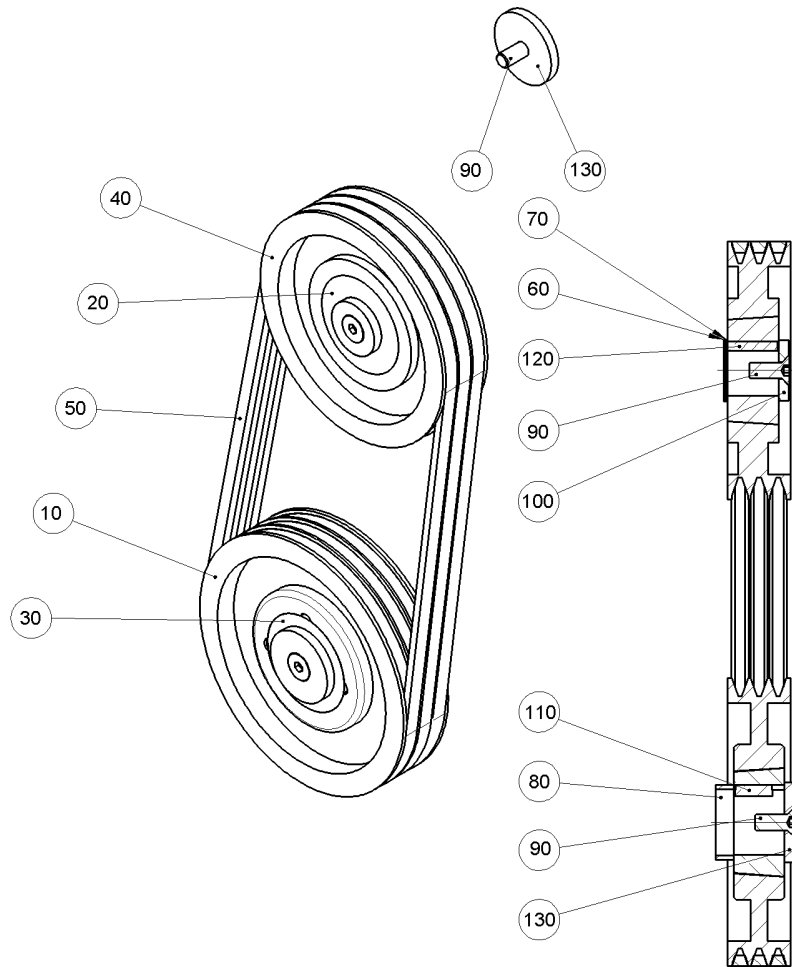



450.02.03.10.00/00
Stücklistennummer / Piece Number / Liste de Pièces / Номер







Pos.	Bestell-Nr. Stock Number Numéro de Commande Номер товара	Menge Amount Quantité Количество	Beschreibung	Description	Description	Описание
------	---	---	--------------	-------------	-------------	----------

10	 50.1.1740.B.X	3,000	KEILRIEMEN B17 1700 LW	POWERBELT REINFORCED	POWERBELT REINFORCED	
----	---	-------	------------------------	----------------------	----------------------	--

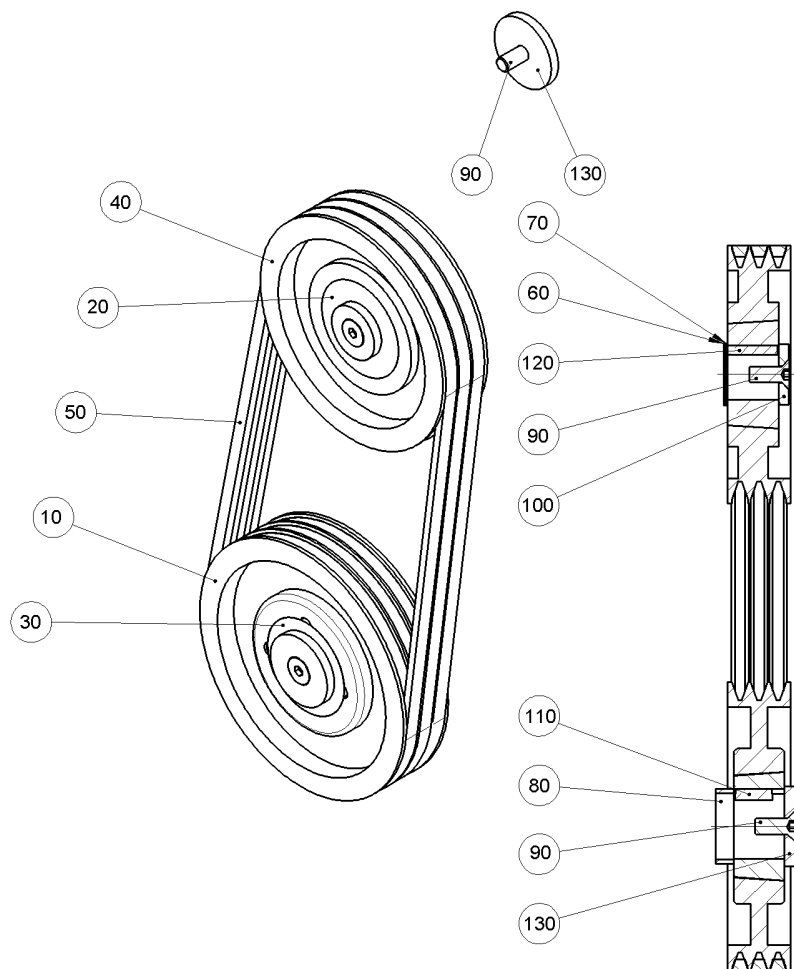

Pos.		Bestell-Nr. Stock Number Numéro de Commande Номер товара	Menge Amount Quantité Количество	Beschreibung	Description	Description	Описание
10		48.01.280.3/00	1,000	KEILRIEMENSCHLEIBE SPB 280X3 TL 3020 KM	V-BELT PULLEY SPB 280X3	V-BELT PULLEY SPB 280X3	
20		49.50.3020/00	1,000	<u>TAPERLOCK 3020 D50</u>	TAPERLOCK-BUSHING D 50 /3020	TAPERLOCK-BUSHING D 50 /3020	
30		49.65.3020/00	1,000	<u>TAPERLOCK 3020 D65</u>	TAPERLOCK-BUSHING D 65 /3020	TAPERLOCK-BUSHING D 65 /3020	
40		48.01.250.3/00	1,000	KEILRIEMENSCHLEIBE SPB 250X3 TL 3020 K0	V-BELT PULLEY 250X3	V-BELT PULLEY 250X3	
50		450.02.03.10.00/00	1,000	<u>KEILRIEMENSATZ KEILRIEMEN B17 1700 LW</u>	POWERBELT SET	POWERBELT SET	
60		100275	1,000	PASSSCHEIBE 50X62X2	ADJUSTING WASHER	ADJUSTING WASHER	
70		18.050.062.1	2,000	PASSSCHEIBE 50X62X1 GEOELT	SPACER	SPACER	
80		796.6.2.66/B	1,000	DISTANZRING D75X4,5X18	DISTANCE RING	DISTANCE RING	
90		01.30.16040.C.V	3,000	SENKSCHRAUBE M16X40 10.9	COUNTERSUNK HEAD SCREW M16X40	COUNTERSUNK HEAD SCREW M16X40	
100		05.10.060.17.0.J1	1,000	SCHEIBE 60XD17X10 GESENKT	WASHER 60XD17X10	WASHER 60XD17X10	
110		09.18.11.40	1,000	PASSFEDER 18X11X40 FORM A	FITTED KEY 18X11X40 DIN6885	FITTED KEY 18X11X40 DIN6885	



Pos.		Bestell-Nr. Stock Number Numéro de Commande Номер товара	Menge Amount Quantité Количество	Beschreibung	Description	Description	Описание
120		09.14.09.50	1,000	PASSFEDER 14X9X50 FORM A	SPRING 14 X 9 X 50 DIN6885	SPRING 14 X 9 X 50 DIN6885	
130		05.10.080.16.5.J1	2,000	SCHEIBE 80XD16,5X10 GESENKT	WASHER 80 X 16,5 D, 10 THICK	WASHER 80 X 16,5 D, 10 THICK	

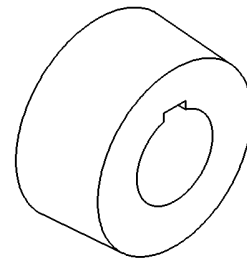

TAPERLOCK 3020 D50 - TAPERLOCK-BUSHING D 50 /3020
TAPERLOCK-BUSHING D 50 /3020 - 49.50.3020/00

49.50.3020/00

Stücklistennummer / Piece Number / Liste de Pièces / Номер



Pos.	Bestell-Nr. Stock Number Numéro de Commande Номер товара	Menge Amount Quantité Количество	Beschreibung	Description	Description	Описание
------	---	---	--------------	-------------	-------------	----------

10	49.1.3020	2,000	INBUSSCHRAUBE	SOCKET SCREW	SOCKET SCREW	
----	-----------	-------	---------------	--------------	--------------	--

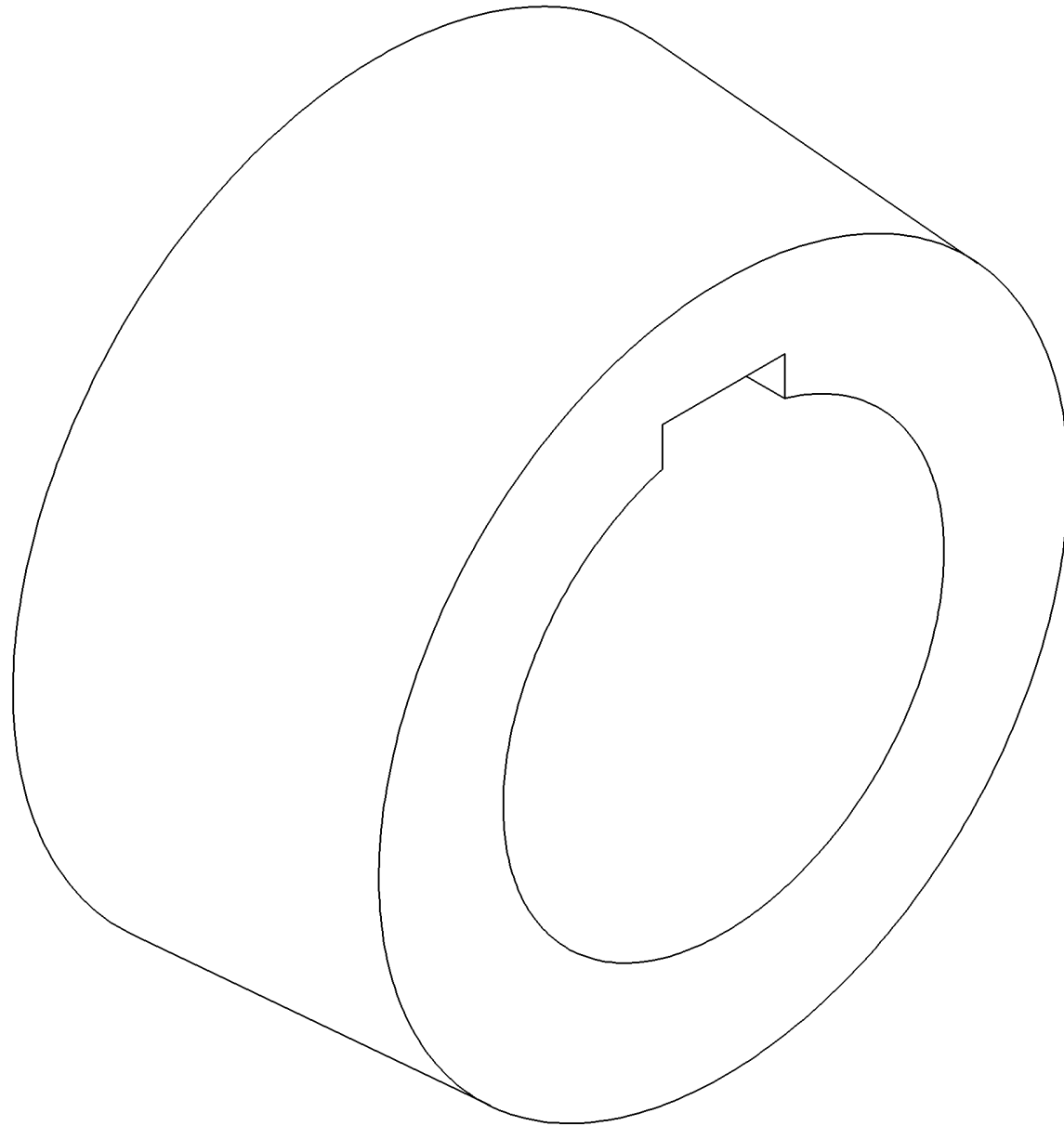

TAPERLOCK 3020 D65 - TAPERLOCK-BUSHING D 65 /3020
TAPERLOCK-BUSHING D 65 /3020 - 49.65.3020/00

49.65.3020/00

Stücklistennummer / Piece Number / Liste de Pièces / Номер



Pos.	Bestell-Nr. Stock Number Numéro de Commande Номер товара	Menge Amount Quantité Количество	Beschreibung	Description	Description	Описание
------	---	---	--------------	-------------	-------------	----------

10	49.1.3020	2,000	INBUSSCHRAUBE	SOCKET SCREW	SOCKET SCREW	
----	-----------	-------	---------------	--------------	--------------	--

KEILRIEMENSATZ KEILRIEMEN B17 1700 LW - POWERBELT SET
POWERBELT SET - 450.02.03.10.00/00

450.02.03.10.00/00
Stücklistennummer / Piece Number / Liste de Pièces / Номер



Pos.	Bestell-Nr. Stock Number Numéro de Commande Номер товара	Menge Amount Quantité Количество	Beschreibung	Description	Description	Описание
------	---	---	--------------	-------------	-------------	----------

10	 50.1.1740.B.X	3,000	KEILRIEMEN B17 1700 LW	POWERBELT REINFORCED	POWERBELT REINFORCED	
----	---	-------	------------------------	----------------------	----------------------	--

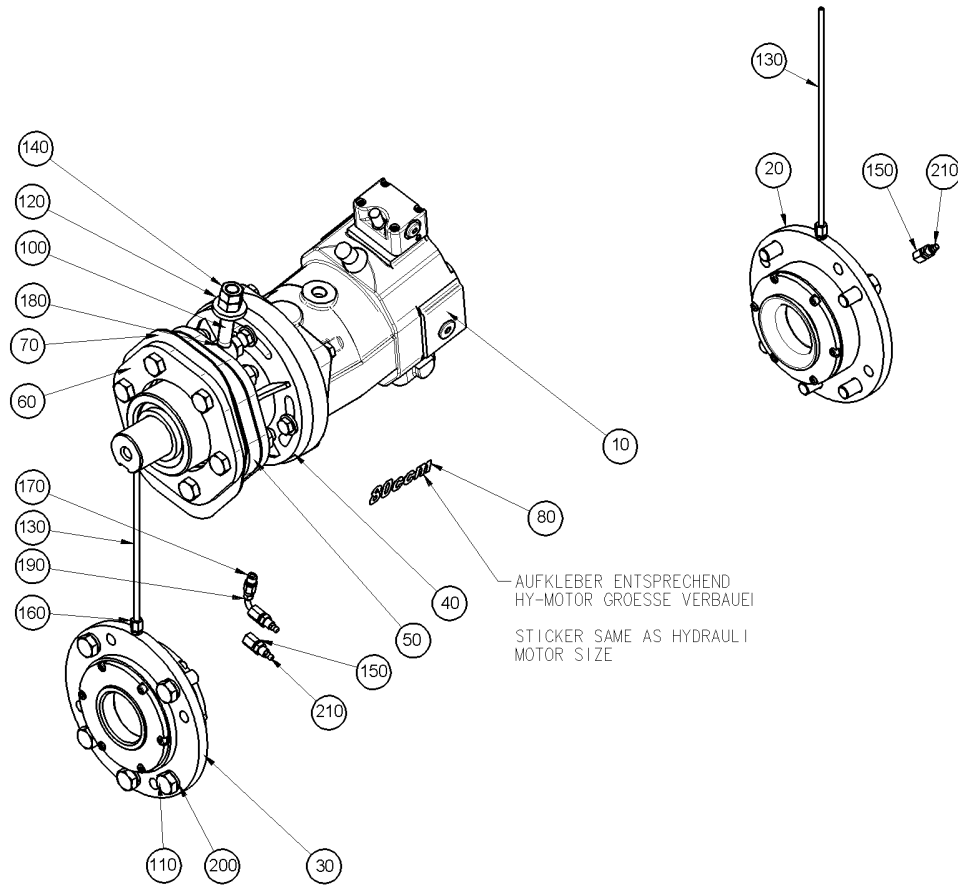

ANTRIEB HYDRAULISCH - HYDRAULIC DRIVE
HYDRAULIC DRIVE - 470.02.00.00.00/01

470.02.00.00.00/01
Stücklistennummer / Piece Number / Liste de Pièces / Homep



Pos.		Bestell-Nr. Stock Number Numéro de Commande Номер товара	Menge Amount Quantité Количество	Beschreibung	Description	Description	Описание
1		740.02.12.00.00/00	1,000	<u>HYDR.-MOTOR A6VM80</u>	HYDRAULIC MOTOR A6VM80	HYDRAULIC MOTOR A6VM80	
2		013.04.5.00/02	1,000	<u>LOSLAGER D65X120</u>	LOOSE BEARING D65X120	LOOSE BEARING D65X120	
3		013.03.5.00/02	1,000	<u>FESTLAGER D65X120</u>	FIXED BEARING D65X120	FIXED BEARING D65X120	
4		551.02.05.02.00/A	1,000	<u>LAGERGLOCKE 4-LOCH, LK 180, DIN 5480</u>	BEARING UNIT	BEARING UNIT	
5		450.02.00.01.02/A	1,000	DISTANZPLATTE	SPACER DISC	SPACER DISC	
6		450.02.02.01.00/00	1,000	<u>FLANSCH</u>	FLANGE	FLANGE	
7		450.02.00.01.01/00	1,000	ABDECKBLECH	METALL SPACER FOR BEARING UNIT	METALL SPACER FOR BEARING UNIT	
8		41375566/00	1,000	AUFKLEBER SET- HYDRAULIKMOTOR	STICKER KIT-HYDRAULIC MOTOR	AUTOCOLLANT KIT-MOTEUR HYDRAULIQUE	
9		799.1.02.42	1,000	<u>HOCHDRUCKSCHL. F.FETT 850</u>	GREASE LINE 850 MM LONG	GREASE LINE 850 MM LONG	
10		01.60.16100	1,000	AUGENSCHRAUBE M16X100 4.6, FORM LB	EYE SCREW M16X100 DIN444	EYE SCREW M16X100 DIN444	
11		01.10.16040	11,0- 00	SKT-SCHRAUBE M16X40 8.8	HEX. SCREW M16X40 DIN933	HEX. SCREW M16X40 DIN933	

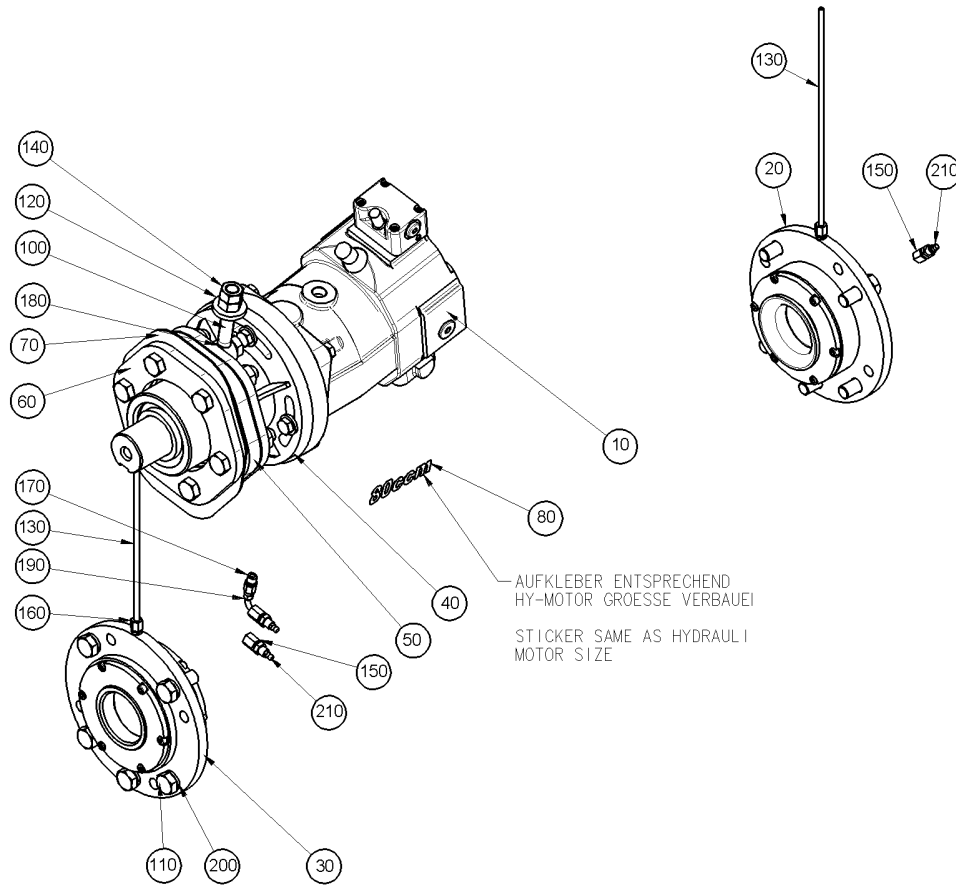

ANTRIEB HYDRAULISCH - HYDRAULIC DRIVE
HYDRAULIC DRIVE - 470.02.00.00.00/01

470.02.00.00.00/01
Stücklistennummer / Piece Number / Liste de Pièces / Homep





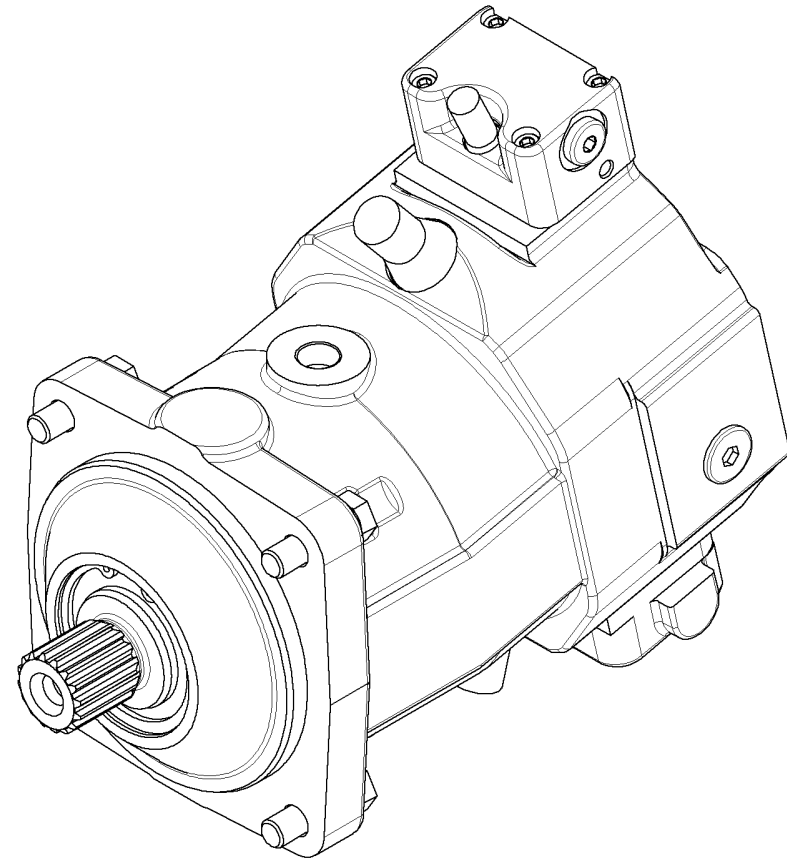
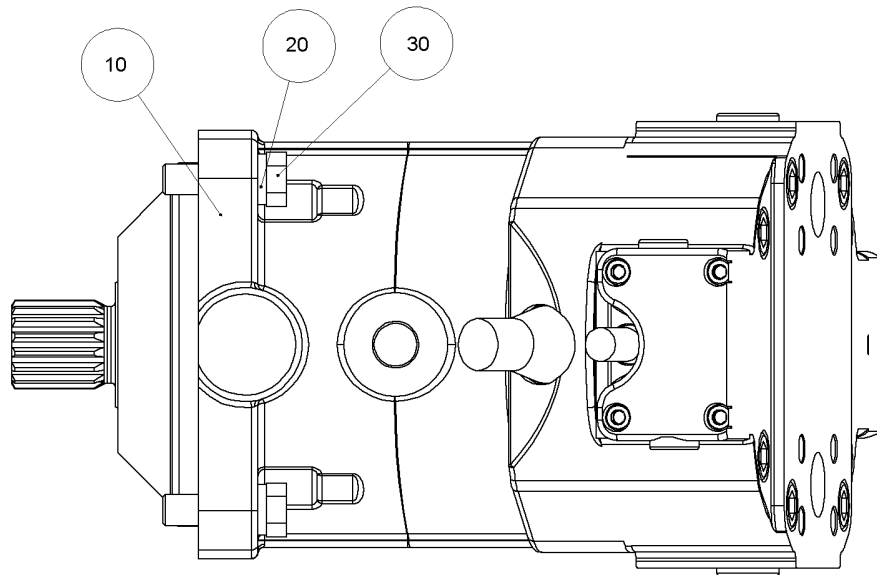

Pos.		Bestell-Nr. Stock Number Numéro de Commande Номер товара	Menge Amount Quantité Количество	Beschreibung	Description	Description	Описание
12		05.04.17	1,000	SCHEIBE B17	WASHER B17 DIN 7349 GALVANIZED	WASHER B17 DIN 7349 GALVANIZED	
13		62.0.010.01.0320/00	2,000	SANCO-KUPFERROHR 6X1 L320, WEICH	SANCO-COPPER PIPE 6X1	SANCO-COPPER PIPE 6X1	
14		03.01.16	8,000	SKT-MUTTER M16 8	NUT M16 DIN 934	NUT M16 DIN 934	
15		100302	3,000	GER-EINSCHR-VERSCHR. 6L M10X1	STRAIGHT SCREW FITTING 6L M10	STRAIGHT SCREW FITTING 6L M10	
16		20.GEV06LL.M10-1/00	3,000	GER-EINSCHR-VERSCHR. 6LL M10X1	STRAIGHT SCREW FITTING 6LL M10	STRAIGHT SCREW FITTING 6LL M10	
17		24.D.002/00	2,000	SCHRAUBHUELSE M7X075, 28 LG	SCREWHUSK F HIGH PRESSURE HOSE	SCREWHUSK F HIGH PRESSURE HOSE	
18		05.01.17	1,000	SCHEIBE ISO 7090-17-200HV	WASHER B17 DIN 125 GALVANIZED	WASHER B17 DIN 125 GALVANIZED	
19		24.D.6-45.1/00	2,000	ROHRSTUTZEN D6X45,1 90G	PIPE NOZZLE BENT 90	PIPE NOZZLE BENT 90	
20		07.02.16	17,0- 00	NORD-LOCK-SCHEIBE FUER M16	NORD-LOCK-DISC FOR M16	NORD-LOCK-DISC FOR M16	
21		24.A.06.100	3,000	SCHMIERNIPPEL M6X1 GERADE, STAHL	GREASE NIPPLE M6X1	GREASE NIPPLE M6X1	



HYDR.-MOTOR A6VM80 - HYDRAULIC MOTOR A6VM80
 HYDRAULIC MOTOR A6VM80 - 740.02.12.00.00/00

740.02.12.00.00/00
 Stücklistennummer / Piece Number / Liste de Pièces / Номер



Pos.		Bestell-Nr. Stock Number Numéro de Commande Номер товара	Menge Amount Quantité Количество	Beschreibung	Description	Description	Описание
10		20.80.136/00	1,000	<u>AXKO-VERSTELLMOTOR 80CCM</u>	AXIAL PISTON MOTOR 80CC	AXIAL PISTON MOTOR 80CC	
20		07.02.12	4,000	NORD-LOCK-SCHEIBE FUER M12	NORD-LOCK-DISC FOR M12	NORD-LOCK-DISC FOR M12	
30		01.10.12040	4,000	SKT-SCHRAUBE M12X40 8.8	SCREW M12X40 DIN 933	SCREW M12X40 DIN 933	

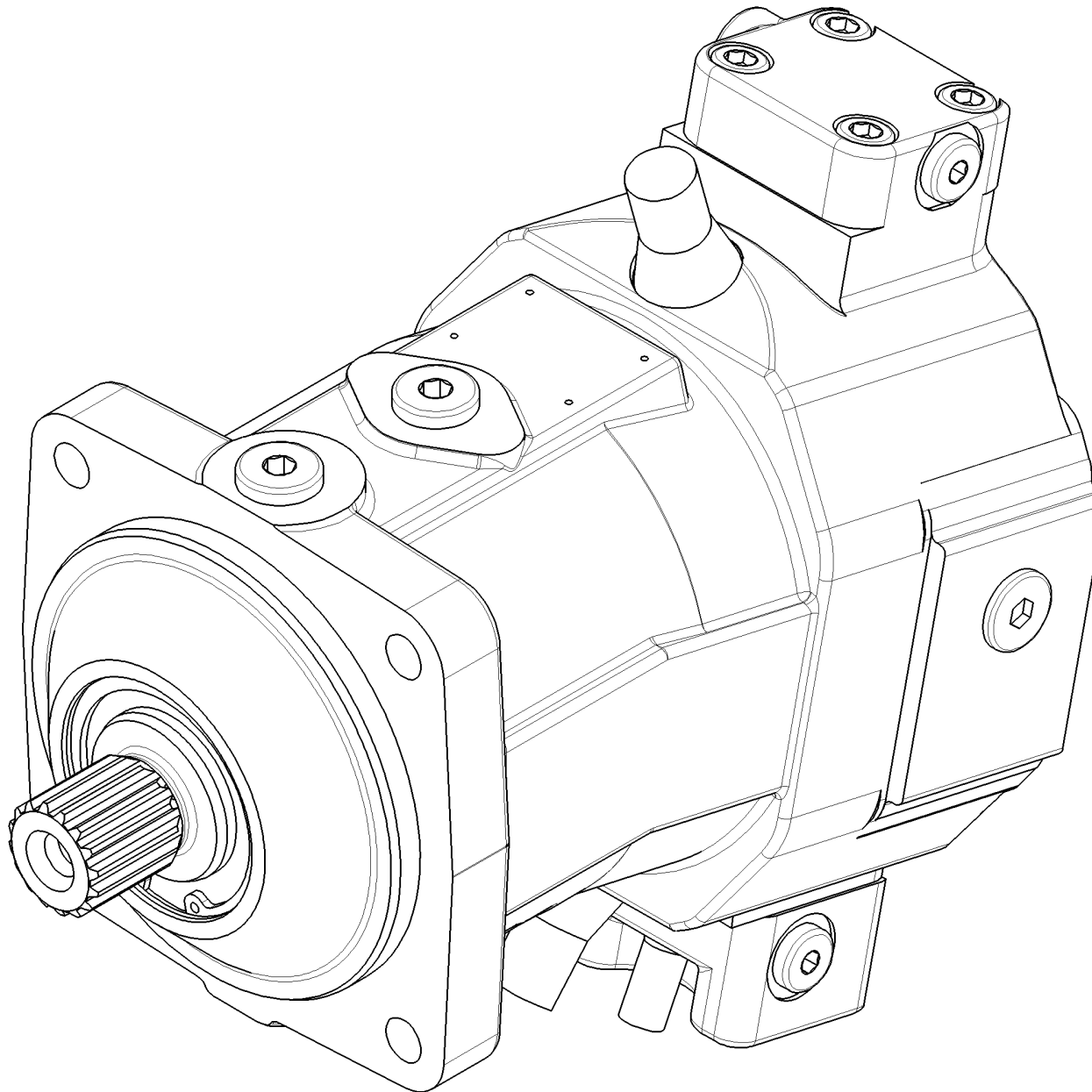

AXKO-VERSTELLMOTOR 80CCM - AXIAL PISTON MOTOR 80CC
AXIAL PISTON MOTOR 80CC - 20.80.136/00

20.80.136/00
Stücklistennummer / Piece Number / Liste de Pièces / Номер



Pos.	Bestell-Nr. Stock Number Numéro de Commande Номер товара	Menge Amount Quantité Количество	Beschreibung	Description	Description	Описание
------	---	---	--------------	-------------	-------------	----------

10	20.80.030.03	1,000	WELLENDICHTRING 50X72X7,5	ROTARY SHAFT SEAL	ROTARY SHAFT SEAL	
----	--------------	-------	---------------------------	-------------------	-------------------	--

LOSLAGER D65X120 - LOOSE BEARING D65X120
LOOSE BEARING D65X120 - 013.04.5.00/02







013.04.5.00/02
Stücklistennummer / Piece Number / Liste de Pièces / Homep



LOSLAGER D65X120 - LOOSE BEARING D65X120
 LOOSE BEARING D65X120 - 013.04.5.00/02

013.04.5.00/02
 Stücklistennummer / Piece Number / Liste de Pièces / Homep





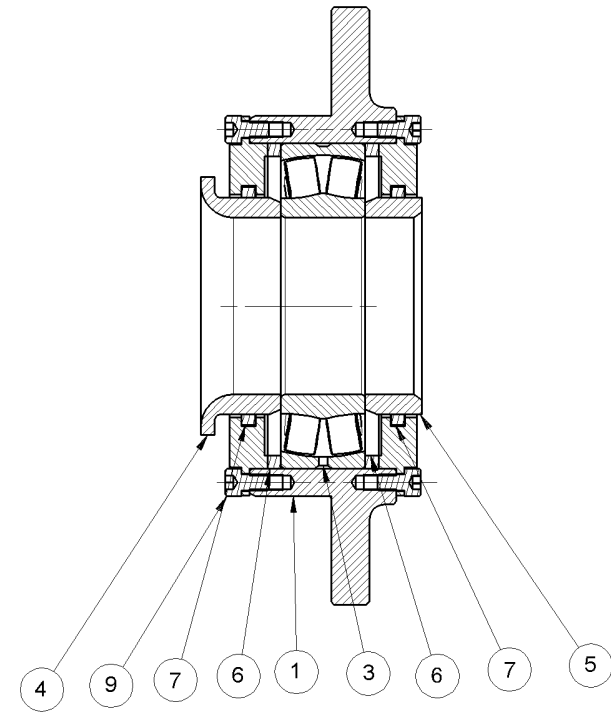
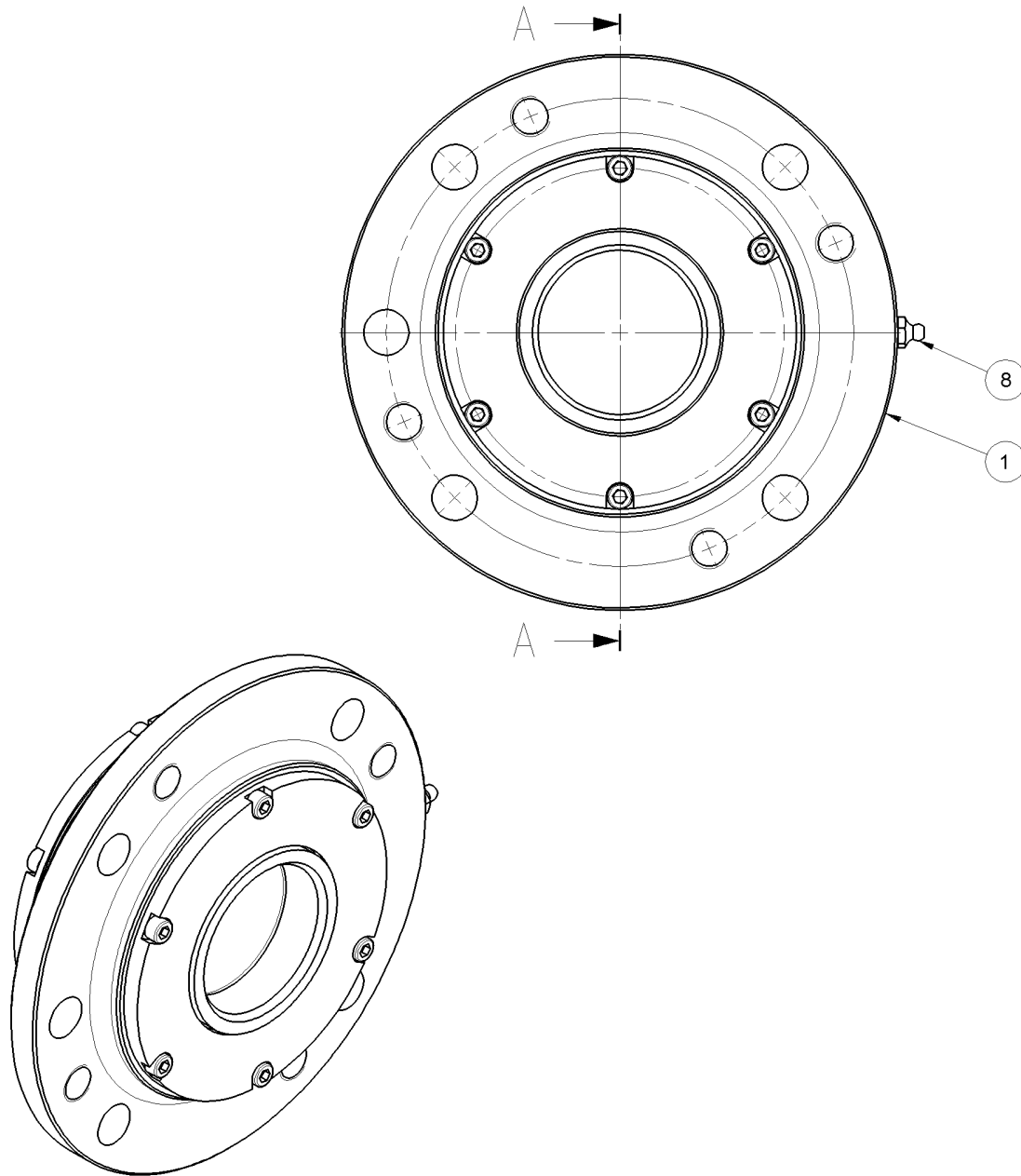

Pos.	Bestell-Nr. Stock Number Numéro de Commande Номер товара	Menge Amount Quantité Количество	Beschreibung	Description	Description	Описание
1	41402345/02	1,000	LAGERGEHAEUSE	BEARING HOUSING	CAGE DE ROULEMENT	
2	 013.04.2.00/B	2,000	ABDICHRING 139,6X81X14	SEAL RING BEARING LOOSE END	SEAL RING BEARING LOOSE END	
3	 01.20.06010	12,0-00	ZYLINDERSCHRAUBE M6X10 8.8	CYL. HEAD SCREW M6X10 DIN 912	CYL. HEAD SCREW M6X10 DIN 912	
4	 013.01.0.04/00	1,000	DISTANZRING D80X65X21	DISTANCE RING /SPACER 65/80X21	DISTANCE RING /SPACER 65/80X21	
5	 013.01.2.06/A	1,000	DISTANZRING D95X65X29,5	DISTANCE RING	DISTANCE RING	
6	 13.A.0002/00	1,000	PENDELKUGELLAGER	SELF ALIGNING BALL BEARING	ROULEMENT A ROTULE SUR BILLE	
7	 14.05.ISKD080/00	2,000	LAMELLENRING 3,5X1,65 D80	LAMELLA RING	LAMELLA RING	
8	 24.A.10.100	1,000	SCHMIERNIPPEL M10X1 GERADE, STAHL	LUBRICATING NIPPLE M10X1	LUBRICATING NIPPLE M10X1	



FESTLAGER D65X120 - FIXED BEARING D65X120
 FIXED BEARING D65X120 - 013.03.5.00/02

013.03.5.00/02
 Stücklistennummer / Piece Number / Liste de Pièces / Номер



Pos.	Bestell-Nr. Stock Number Numéro de Commande Номер товара	Menge Amount Quantité Количество	Beschreibung	Description	Description	Описание
1	41402345/02	1,000	LAGERGEHAEUSE	BEARING HOUSING	CAGE DE ROULEMENT	
2	 013.04.2.00/B	2,000	ABDICHRING 139,6X81X14	SEAL RING BEARING LOOSE END	SEAL RING BEARING LOOSE END	
3	 13.A.0002/00	1,000	PENDELKUGELLAGER	SELF ALIGNING BALL BEARING	ROULEMENT A ROTULE SUR BILLE	
4	 013.01.2.06/A	1,000	DISTANZRING D95X65X29,5	DISTANCE RING	DISTANCE RING	
5	 013.01.0.04/00	1,000	DISTANZRING D80X65X21	DISTANCE RING /SPACER 65/80X21	DISTANCE RING /SPACER 65/80X21	
6	 14.03.007/00	2,000	FESTRING FRB120X5	FIXED RING FRB120X5	FIXED RING FRB120X5	
7	 14.05.ISKD080/00	2,000	LAMELLENRING 3,5X1,65 D80	LAMELLA RING	LAMELLA RING	
8	 24.A.10.100	1,000	SCHMIERNIPPEL M10X1 GERADE, STAHL	LUBRICATING NIPPLE M10X1	LUBRICATING NIPPLE M10X1	
9	 01.20.06010	12,0-00	ZYLINDERSCHRAUBE M6X10 8.8	CYL. HEAD SCREW M6X10 DIN 912	CYL. HEAD SCREW M6X10 DIN 912	

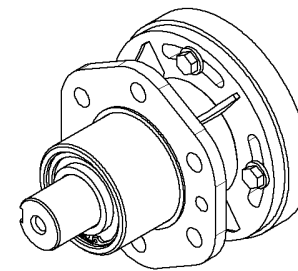
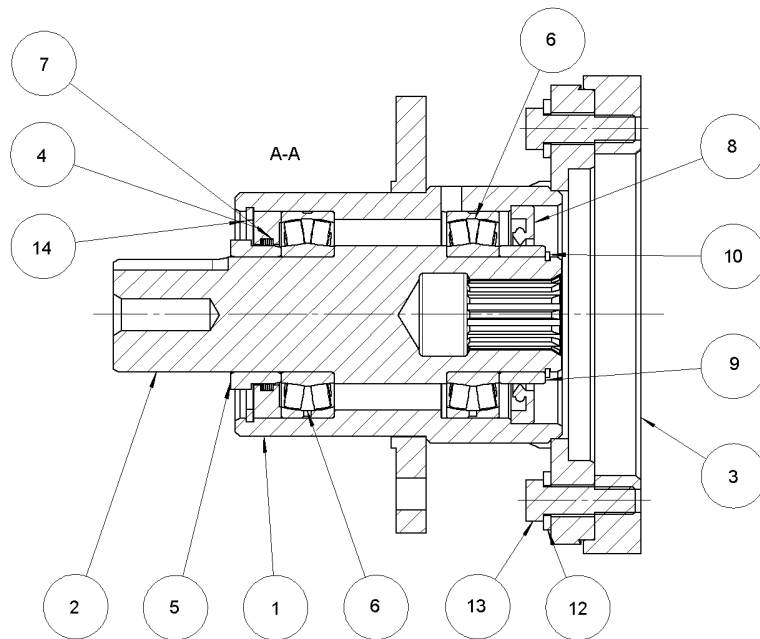
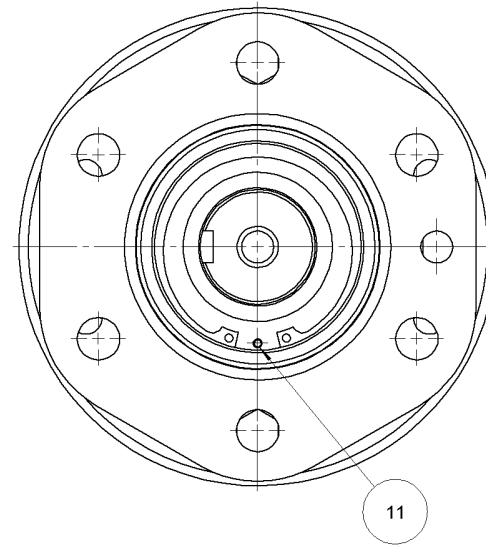
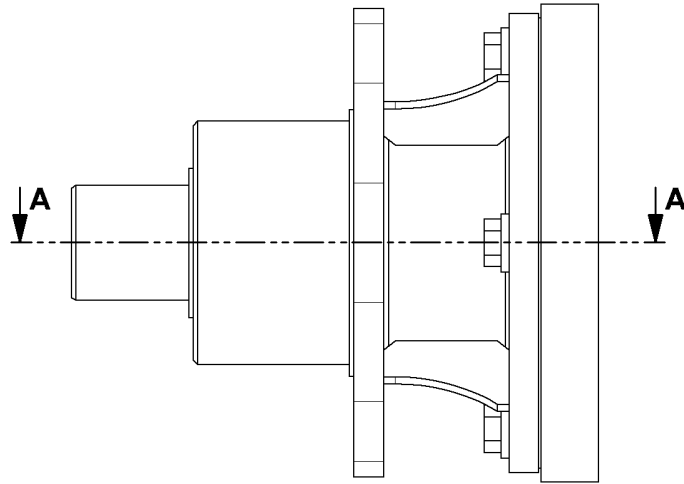

LAGERGLOCKE 4-LOCH, LK 180, DIN 5480 - BEARING UNIT
BEARING UNIT - 551.02.05.02.00/A

551.02.05.02.00/A
Stücklistennummer / Piece Number / Liste de Pièces / Номер



Pos.		Bestell-Nr. Stock Number Numéro de Commande Номер товара	Menge Amount Quantité Количество	Beschreibung	Description	Description	Описание
10		551.02.05.22.00/03	1,000	LAGERGLOCKE-GESCHWEISST	BEARING BELL-WELDED	CLOCHE DE PALIER-SOUDE	
20		551.02.05.02.01/A	1,000	VERTEILERWELLE INNENVERZÄHNUNG DIN 5480	SHAFT	SHAFT	
30		740.02.03.00.02/A	1,000	ADAPTERSCHEIBE	ADAPTERSCHEIBE	ADAPTERSCHEIBE	
40		991.05.04.00.01/00	1,000	ABDICHRING	SEALING RING	SEALING RING	
50		991.05.04.00.02/00	1,000	DISTANZRING	DISTANCE RING	DISTANCE RING	
60		13.A.0001/00	2,000	PENDELKUGELLAGER	SELF ALIGNING BALL BEARING	ROULEMENT A ROTULE SUR BILLE	
70		14.05.ISKD060/00	1,000	LAMELLENRING 2,8X1,65 D60	LAMELLA RING	LAMELLA RING	
80		19.02.21.010	1,000	SIMMERRING 60X95X10 BASL, NBR70	SIMMERRING 60X95X10 BASL, NBR70	SIMMERRING 60X95X10 BASL, NBR70	
90		14.0006.02/00	1,000	INNENRING IR50X60X20	INNENRING IR50X60X20	INNENRING IR50X60X20	
100		16.01.A050	1,000	SICHERUNGSRING A50X2,0	RETAINING RING A50 ! CAREFULL!	RETAINING RING A50 ! CAREFULL!	
110		25.01.010.04	1,000	SPANNSTIFT 4X10 STAHL	DOWEL PIN 4X10 DIN 1481	DOWEL PIN 4X10 DIN 1481	

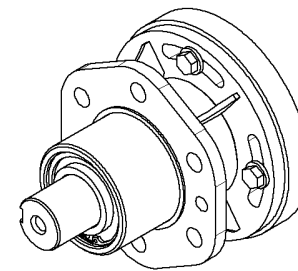
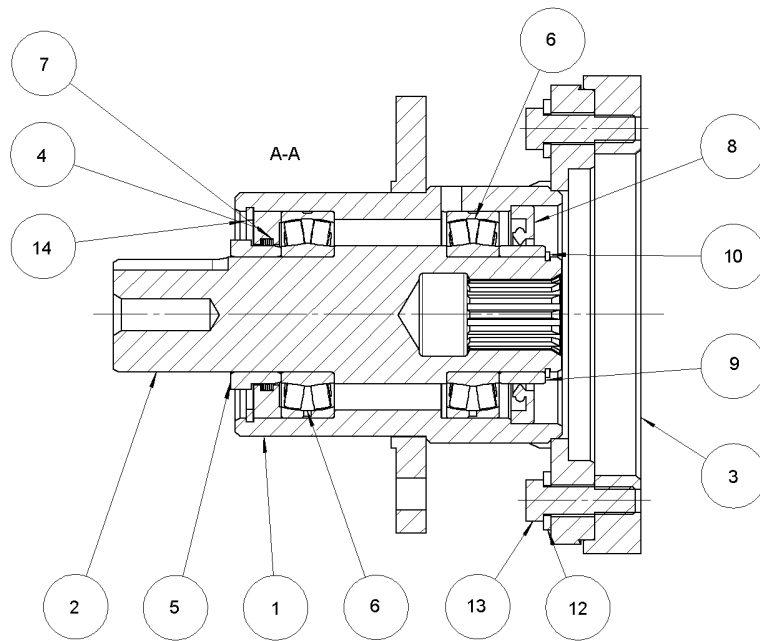
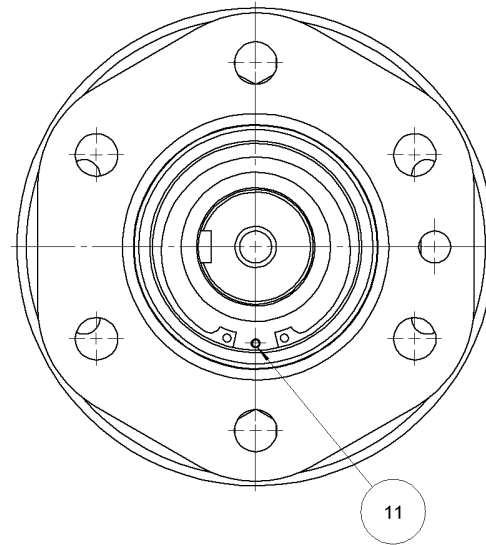
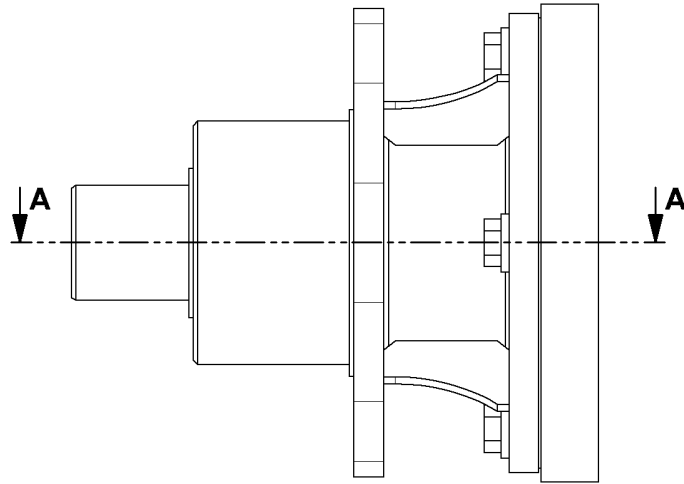



BOM:560.00.00.00.00 MAT: 551.02.05.02.00 DRW/551.02.05.02.00/DE/A 10005427 2020-07-16

LAGERGLOCKE 4-LOCH, LK 180, DIN 5480 - BEARING UNIT
 BEARING UNIT - 551.02.05.02.00/A

551.02.05.02.00/A
 Stücklistennummer / Piece Number / Liste de Pièces / Номер



Pos.	Bestell-Nr. Stock Number Numéro de Commande Номер товара	Menge Amount Quantité Количество	Beschreibung	Description	Description	Описание
120	 07.03.12	4,000	NORD-LOCK-SCHEIBE FUER M12	NORD-LOCK WASHER M12	NORD-LOCK WASHER M12	
130	 01.10.12040	4,000	SKT-SCHRAUBE M12X40 8.8	SCREW M12X40 DIN 933	SCREW M12X40 DIN 933	
140	 16.01.J090	1,000	SICHERUNGSRING J90X3,0	RETAINING RING J90 ! CAREFULL!!	RETAINING RING J90 ! CAREFULL!!	

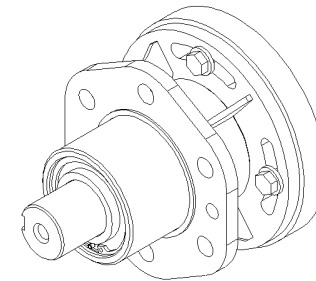
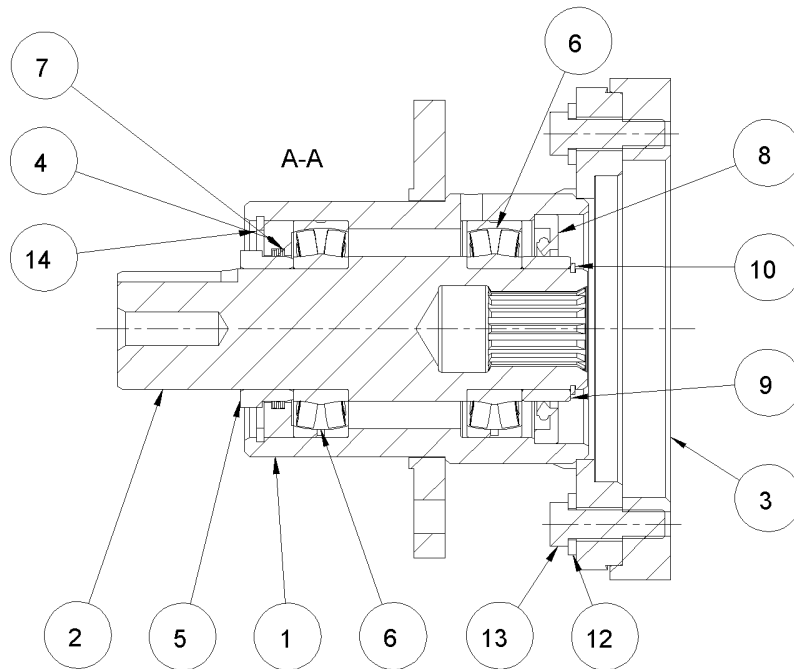
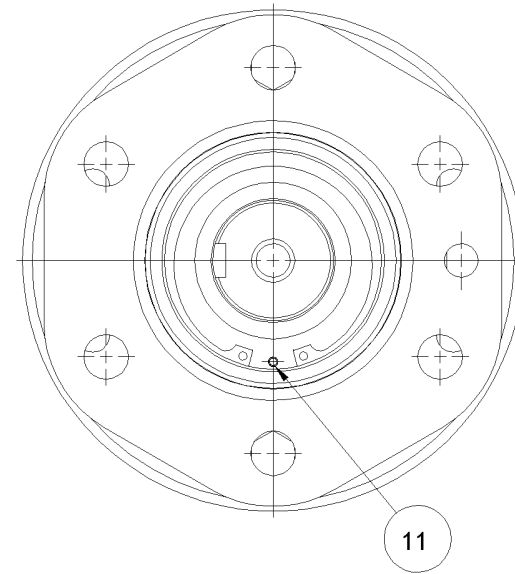
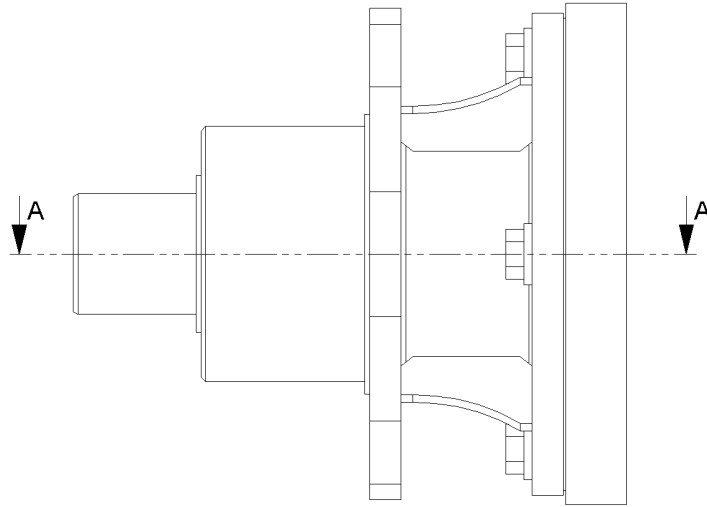

LAGERGLOCKE 4-LOCH, LK 180, DIN 5480 - BEARING UNIT
BEARING UNIT - 551.02.05.02.00/A

551.02.05.02.00/A
Stücklistennummer / Piece Number / Liste de Pièces / Номер



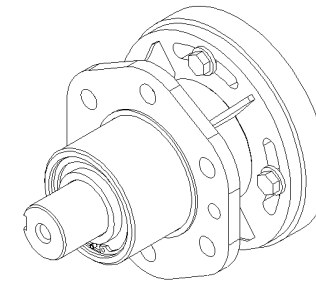
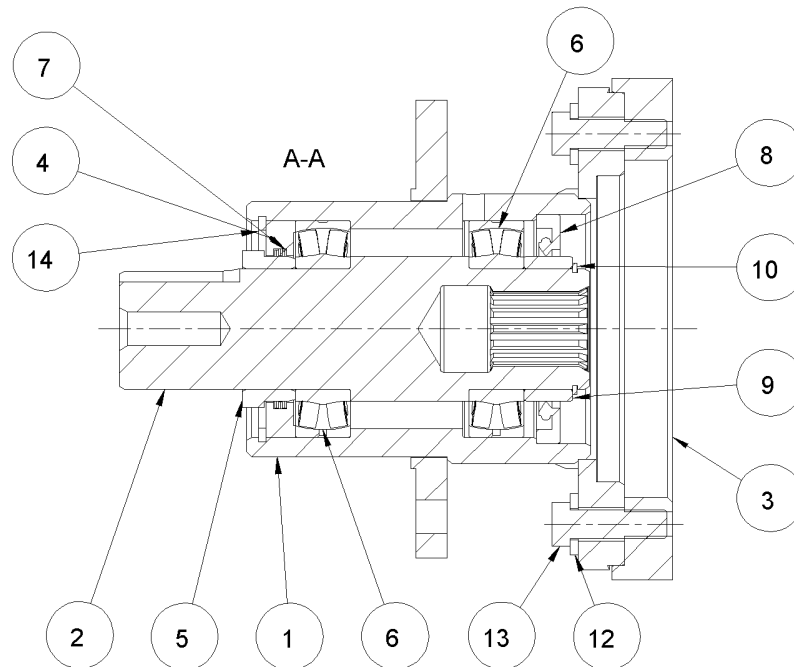
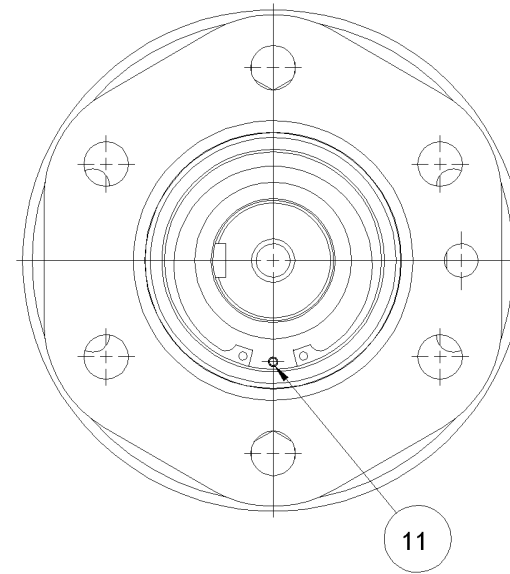
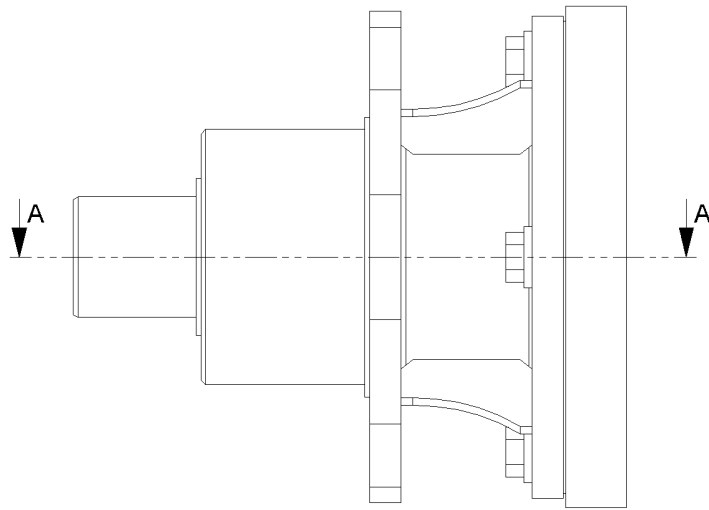

Pos.		Bestell-Nr. Stock Number Numéro de Commande Номер товара	Menge Amount Quantité Количество	Beschreibung	Description	Description	Описание
10		551.02.05.22.00/03	1,000	LAGERGLOCKE-GESCHWEISST	BEARING BELL-WELDED	CLOCHE DE PALIER-SOUDE	
20		551.02.05.02.01/A	1,000	VERTEILERWELLE INNENVERZÄHNUNG DIN 5480	SHAFT	SHAFT	
30		740.02.03.00.02/A	1,000	ADAPTERSCHEIBE	ADAPTERSCHEIBE	ADAPTERSCHEIBE	
40		991.05.04.00.01/00	1,000	ABDICHRING	SEALING RING	SEALING RING	
50		991.05.04.00.02/00	1,000	DISTANZRING	DISTANCE RING	DISTANCE RING	
60		13.A.0001/00	2,000	PENDELKUGELLAGER	SELF ALIGNING BALL BEARING	ROULEMENT A ROTULE SUR BILLE	
70		14.05.ISKD060/00	1,000	LAMELLENRING 2,8X1,65 D60	LAMELLA RING	LAMELLA RING	
80		19.02.21.010	1,000	SIMMERRING 60X95X10 BASL, NBR70	SIMMERRING 60X95X10 BASL, NBR70	SIMMERRING 60X95X10 BASL, NBR70	
90		14.0006.02/00	1,000	INNENRING IR50X60X20	INNENRING IR50X60X20	INNENRING IR50X60X20	
100		16.01.A050	1,000	SICHERUNGSRING A50X2,0	RETAINING RING A50 ! CAREFULL!	RETAINING RING A50 ! CAREFULL!	
110		25.01.010.04	1,000	SPANNSTIFT 4X10 STAHL	DOWEL PIN 4X10 DIN 1481	DOWEL PIN 4X10 DIN 1481	



LAGERGLOCKE 4-LOCH, LK 180, DIN 5480 - BEARING UNIT
 BEARING UNIT - 551.02.05.02.00/A

551.02.05.02.00/A
 Stücklistennummer / Piece Number / Liste de Pièces / Номер



Pos.	Bestell-Nr. Stock Number Numéro de Commande Номер товара	Menge Amount Quantité Количество	Beschreibung	Description	Description	Описание
120	 07.03.12	4,000	NORD-LOCK-SCHEIBE FUER M12	NORD-LOCK WASHER M12	NORD-LOCK WASHER M12	
130	 01.10.12040	4,000	SKT-SCHRAUBE M12X40 8.8	SCREW M12X40 DIN 933	SCREW M12X40 DIN 933	
140	 16.01.J090	1,000	SICHERUNGSRING J90X3,0	RETAINING RING J90 ! CAREFULL!!	RETAINING RING J90 ! CAREFULL!!	

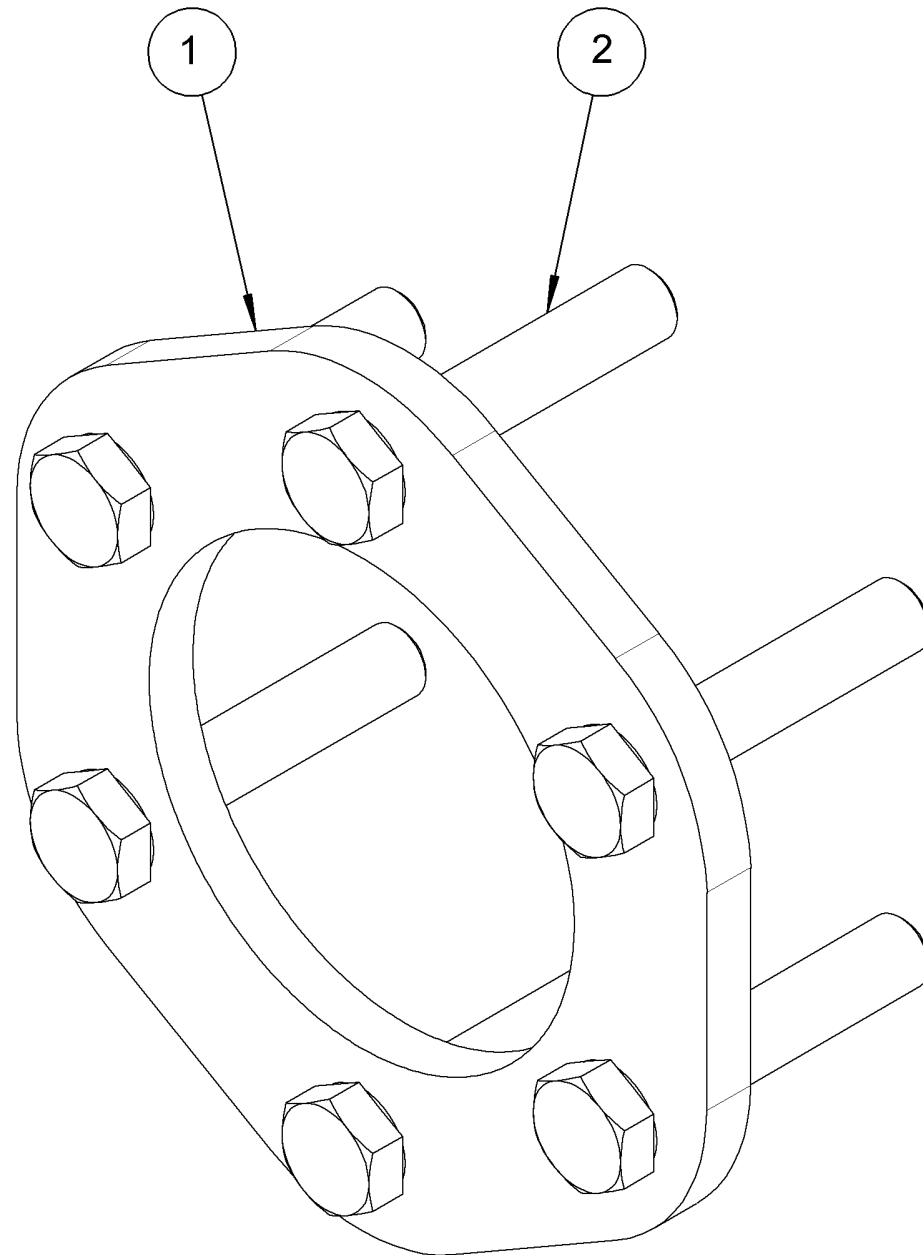

FLANSCH - FLANGE
FLANGE - 450.02.02.01.00/00

450.02.02.01.00/00
Stücklistennummer / Piece Number / Liste de Pièces / Номер



Pos.	Bestell-Nr. Stock Number Numéro de Commande Номер товара	Menge Amount Quantité Количество	Beschreibung	Description	Description	Описание
------	---	---	--------------	-------------	-------------	----------

20	 01.10.16080	6,000	SKT-SCHRAUBE M16X80 8.8	SCREW M16X80 DIN933	SCREW M16X80 DIN933	
----	---	-------	-------------------------	---------------------	---------------------	--

HOCHDRUCKSCHL. F.FETT 850 - GREASE LINE 850 MM LONG
GREASE LINE 850 MM LONG - 799.1.02.42

799.1.02.42

Stücklistennummer / Piece Number / Liste de Pièces / Homep



HOCHDRUCKSCHL. F.FETT 850 - GREASE LINE 850 MM LONG
GREASE LINE 850 MM LONG - 799.1.02.42

799.1.02.42

Stücklistennummer / Piece Number / Liste de Pièces / Номер



Pos.	Bestell-Nr. Stock Number Numéro de Commande Номер товара	Menge Amount Quantité Количество	Beschreibung	Description	Description	Описание
------	---	---	--------------	-------------	-------------	----------

10	24.D.001/00	0,850	HOCHDRUCKSCHLAUCH D4, D 8,6, GERADE	HIGH PRESSURE HOSE FOR GREASE	HIGH PRESSURE HOSE FOR GREASE	
----	-------------	-------	--	----------------------------------	----------------------------------	--

HOCHDRUCKSCHLAUCH D4, D 8,6, GERADE - HIGH PRESSURE HOSE FOR GREASE
HIGH PRESSURE HOSE FOR GREASE - 24.D.001/00

24.D.001/00
Stücklistennummer / Piece Number / Liste de Pièces / Homep

Pinoth[®]

HOCHDRUCKSCHLAUCH D4, D 8,6, GERADE - HIGH PRESSURE HOSE FOR GREASE
HIGH PRESSURE HOSE FOR GREASE - 24.D.001/00

24.D.001/00
Stücklistennummer / Piece Number / Liste de Pièces / Номер



Pos.	Bestell-Nr. Stock Number Numéro de Commande Номер товара	Menge Amount Quantité Количество	Beschreibung	Description	Description	Описание
------	---	---	--------------	-------------	-------------	----------

10	 24.D.002/00	1,000	SCHRAUBHUELSE M7X075, 28 LG	SCREWHUSK F HIGH PRESSURE HOSE	SCREWHUSK F HIGH PRESSURE HOSE	
----	---	-------	-----------------------------	--------------------------------	--------------------------------	--

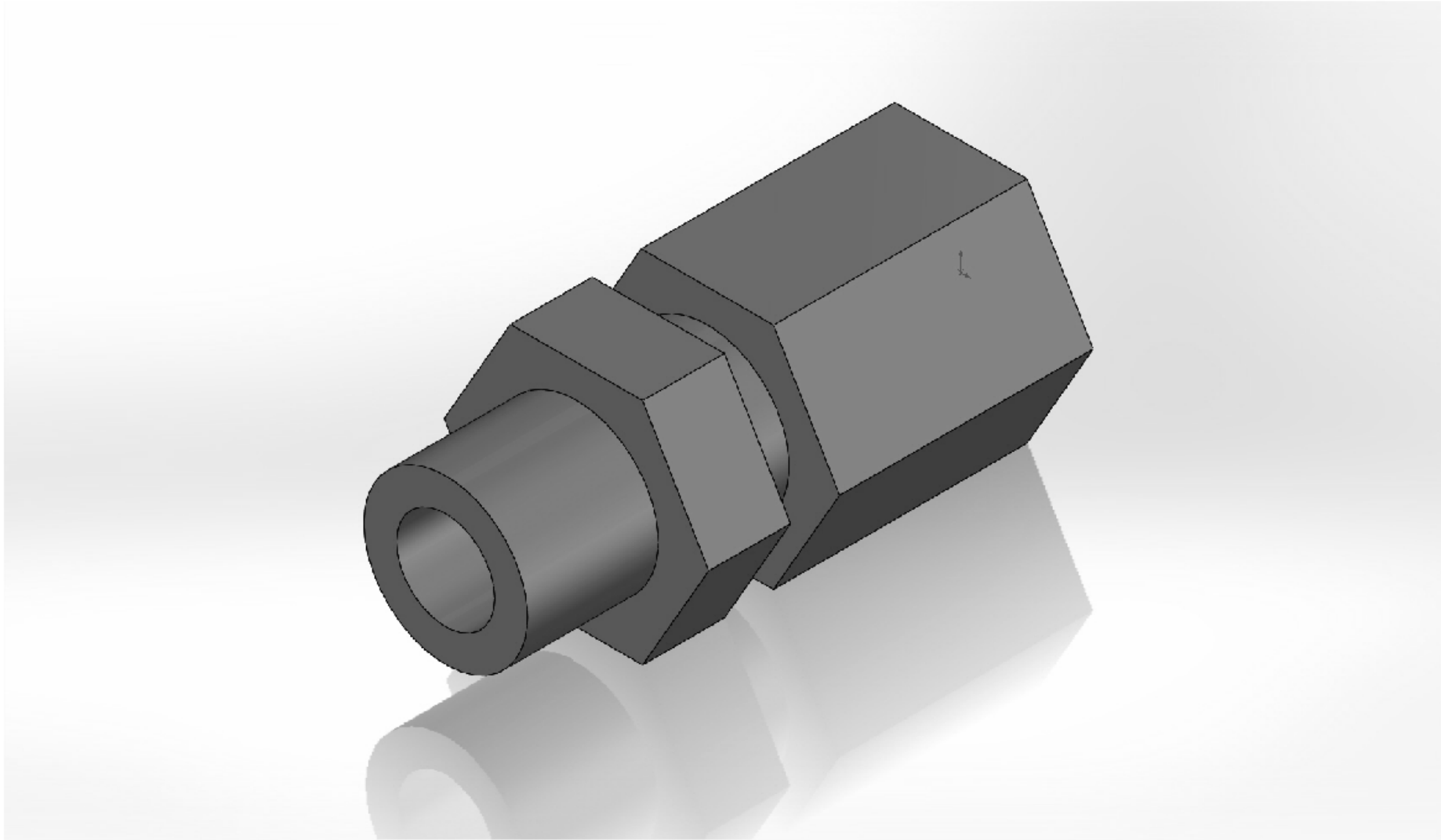

GER-EINSCHR-VERSCHR. 6L M10X1 - STRAIGHT SCREW FITTING 6L M10
STRAIGHT SCREW FITTING 6L M10 - 100302

100302

Stücklistennummer / Piece Number / Liste de Pièces / Номер



Pos.	Bestell-Nr. Stock Number Numéro de Commande Номер товара	Menge Amount Quantité Количество	Beschreibung	Description	Description	Описание
------	---	---	--------------	-------------	-------------	----------

10



20.GEV06L.M10-1/00

1,000

GER-EINSCHR-VERSCHR. 6L
M10X1

STRAIGHT SCREW FIT. 6L
M10X1,0



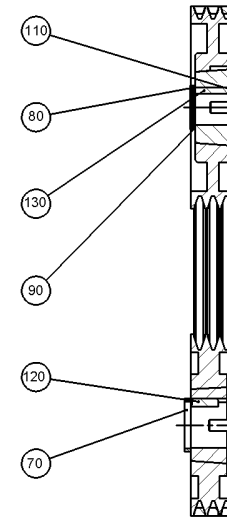
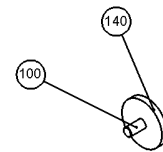
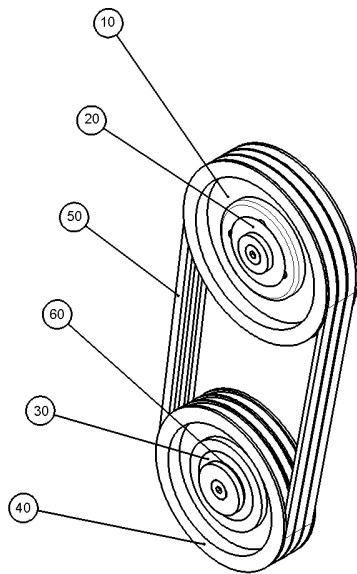









STRAIGHT SCREW FIT. 6L
M10X1,0



RIEMENUEBERSETZUNG I=0,89 - BELT RATIO I=0,89
 BELT RATIO I=0,89 - 470.02.04.00.00/A

470.02.04.00.00/A
 Stücklistennummer / Piece Number / Liste de Pièces / Homep



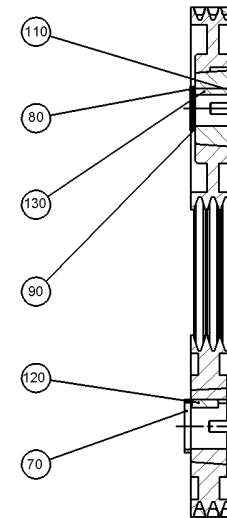
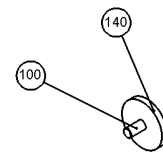
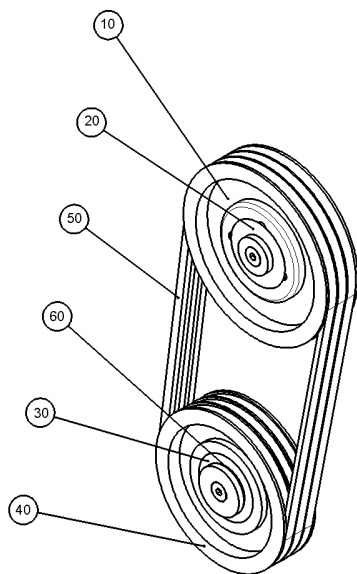

Pos.		Bestell-Nr. Stock Number Numéro de Commande Номер товара	Menge Amount Quantité Количество	Beschreibung	Description	Description	Описание
10		48.01.280.3/00	1,000	KEILRIEMENSCHLEIBE SPB 280X3 TL 3020 KM	V-BELT PULLEY SPB 280X3	V-BELT PULLEY SPB 280X3	
20		49.50.3020/00	1,000	<u>TAPERLOCK 3020 D50</u>	TAPERLOCK-BUSHING D 50 /3020	TAPERLOCK-BUSHING D 50 /3020	
30		49.65.3020/00	1,000	<u>TAPERLOCK 3020 D65</u>	TAPERLOCK-BUSHING D 65 /3020	TAPERLOCK-BUSHING D 65 /3020	
40		48.01.250.3/00	1,000	KEILRIEMENSCHLEIBE SPB 250X3 TL 3020 K0	V-BELT PULLEY 250X3	V-BELT PULLEY 250X3	
50		450.02.03.10.00/00	1,000	<u>KEILRIEMENSATZ KEILRIEMEN B17 1700 LW</u>	POWERBELT SET	POWERBELT SET	
60		754.20.5.02/A	1,000	<u>DISTANZRING D75X4,5X4</u>	DISTANCE RING	DISTANCE RING	
70		796.6.2.65/B	1,000	<u>DISTANZRING D75X4,5X9</u>	DISTANCE RING	DISTANCE RING	
80		100275	2,000	PASSSCHEIBE 50X62X2	ADJUSTING WASHER	ADJUSTING WASHER	
90		18.050.062.1	3,000	PASSSCHEIBE 50X62X1 GEOELT	SPACER	SPACER	
100		01.30.16040.C.V	3,000	SENKSCHEIBE M16X40 10.9	COUNTERSUNK HEAD SCREW M16X40	COUNTERSUNK HEAD SCREW M16X40	
110		05.10.060.17.0.J1	1,000	SCHEIBE 60XD17X10 GESENKT	WASHER 60XD17X10	WASHER 60XD17X10	



RIEMENUEBERSETZUNG I=0,89 - BELT RATIO I=0,89
BELT RATIO I=0,89 - 470.02.04.00.00/A

470.02.04.00.00/A
Stücklistennummer / Piece Number / Liste de Pièces / Номер



Pos.		Bestell-Nr. Stock Number Numéro de Commande Номер товара	Menge Amount Quantité Количество	Beschreibung	Description	Description	Описание
120		09.18.11.40	1,000	PASSFEDER 18X11X40 FORM A	FITTED KEY 18X11X40 DIN6885	FITTED KEY 18X11X40 DIN6885	
130		09.14.09.50	1,000	PASSFEDER 14X9X50 FORM A	SPRING 14 X 9 X 50 DIN6885	SPRING 14 X 9 X 50 DIN6885	
140		05.10.080.16.5.J1	2,000	SCHEIBE 80XD16,5X10 GESENKT	WASHER 80 X 16,5 D, 10 THICK	WASHER 80 X 16,5 D, 10 THICK	

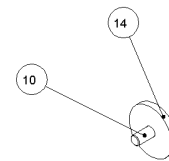
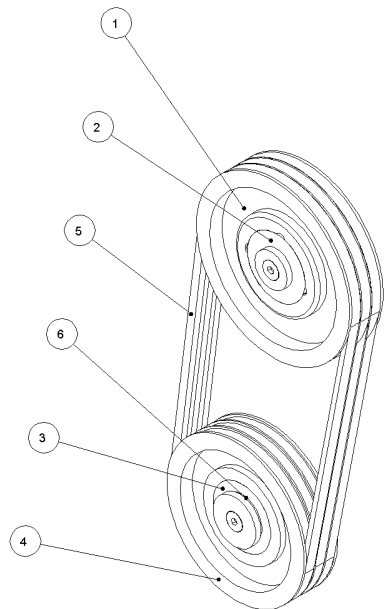
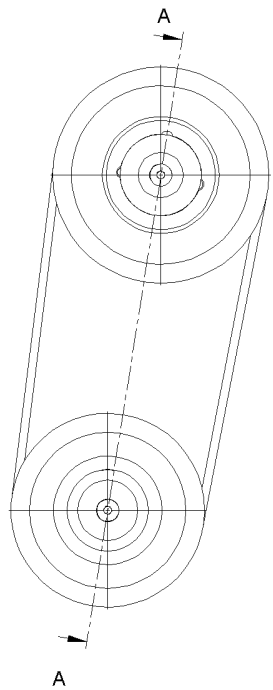



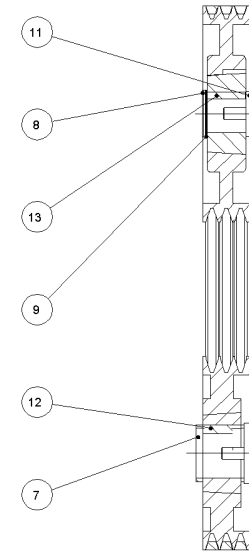









A-A



RIEMENUEBERSETZUNG I=0,89 - BELT RATIO I=0,89
 BELT RATIO I=0,89 - 470.02.04.00.00/A

470.02.04.00.00/A
 Stücklistennummer / Piece Number / Liste de Pièces / Homep



Pos.		Bestell-Nr. Stock Number Numéro de Commande Номер товара	Menge Amount Quantité Количество	Beschreibung	Description	Description	Описание
10		48.01.280.3/00	1,000	KEILRIEMENSCHLEIBE SPB 280X3 TL 3020 KM	V-BELT PULLEY SPB 280X3	V-BELT PULLEY SPB 280X3	
20		49.50.3020/00	1,000	<u>TAPERLOCK 3020 D50</u>	TAPERLOCK-BUSHING D 50 /3020	TAPERLOCK-BUSHING D 50 /3020	
30		49.65.3020/00	1,000	<u>TAPERLOCK 3020 D65</u>	TAPERLOCK-BUSHING D 65 /3020	TAPERLOCK-BUSHING D 65 /3020	
40		48.01.250.3/00	1,000	KEILRIEMENSCHLEIBE SPB 250X3 TL 3020 K0	V-BELT PULLEY 250X3	V-BELT PULLEY 250X3	
50		450.02.03.10.00/00	1,000	<u>KEILRIEMENSATZ KEILRIEMEN B17 1700 LW</u>	POWERBELT SET	POWERBELT SET	
60		754.20.5.02/A	1,000	<u>DISTANZRING D75X4,5X4</u>	DISTANCE RING	DISTANCE RING	
70		796.6.2.65/B	1,000	<u>DISTANZRING D75X4,5X9</u>	DISTANCE RING	DISTANCE RING	
80		100275	2,000	PASSSCHEIBE 50X62X2	ADJUSTING WASHER	ADJUSTING WASHER	
90		18.050.062.1	3,000	PASSSCHEIBE 50X62X1 GEOELT	SPACER	SPACER	
100		01.30.16040.C.V	3,000	SENKSCHRAUBE M16X40 10.9	COUNTERSUNK HEAD SCREW M16X40	COUNTERSUNK HEAD SCREW M16X40	
110		05.10.060.17.0.J1	1,000	SCHEIBE 60XD17X10 GESENKT	WASHER 60XD17X10	WASHER 60XD17X10	

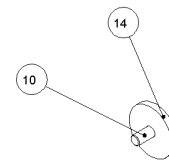
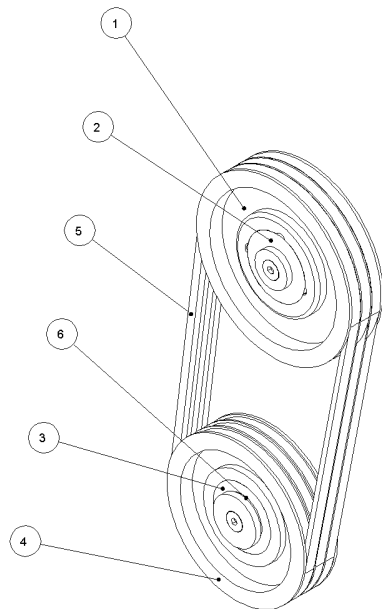
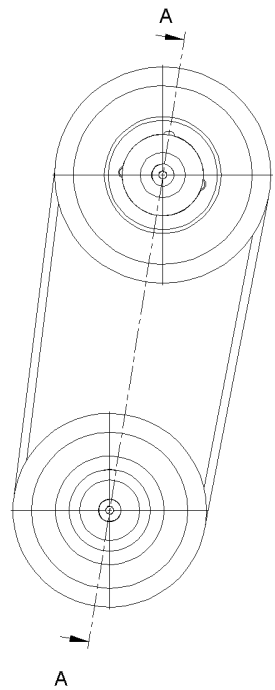

A-A

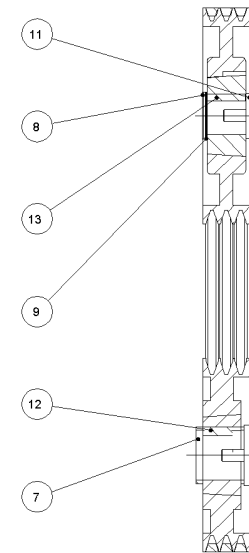

RIEMENUEBERSETZUNG I=0,89 - BELT RATIO I=0,89
BELT RATIO I=0,89 - 470.02.04.00.00/A

470.02.04.00.00/A
Stücklistennummer / Piece Number / Liste de Pièces / Номер



Pos.		Bestell-Nr. Stock Number Numéro de Commande Номер товара	Menge Amount Quantité Количество	Beschreibung	Description	Description	Описание
120		09.18.11.40	1,000	PASSFEDER 18X11X40 FORM A	FITTED KEY 18X11X40 DIN6885	FITTED KEY 18X11X40 DIN6885	
130		09.14.09.50	1,000	PASSFEDER 14X9X50 FORM A	SPRING 14 X 9 X 50 DIN6885	SPRING 14 X 9 X 50 DIN6885	
140		05.10.080.16.5.J1	2,000	SCHEIBE 80XD16,5X10 GESENKT	WASHER 80 X 16,5 D, 10 THICK	WASHER 80 X 16,5 D, 10 THICK	

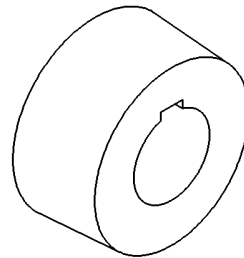

TAPERLOCK 3020 D50 - TAPERLOCK-BUSHING D 50 /3020
TAPERLOCK-BUSHING D 50 /3020 - 49.50.3020/00

49.50.3020/00

Stücklistennummer / Piece Number / Liste de Pièces / Номер



Pos.	Bestell-Nr. Stock Number Numéro de Commande Номер товара	Menge Amount Quantité Количество	Beschreibung	Description	Description	Описание
------	---	---	--------------	-------------	-------------	----------

10	49.1.3020	2,000	INBUSSCHRAUBE	SOCKET SCREW	SOCKET SCREW	
----	-----------	-------	---------------	--------------	--------------	--

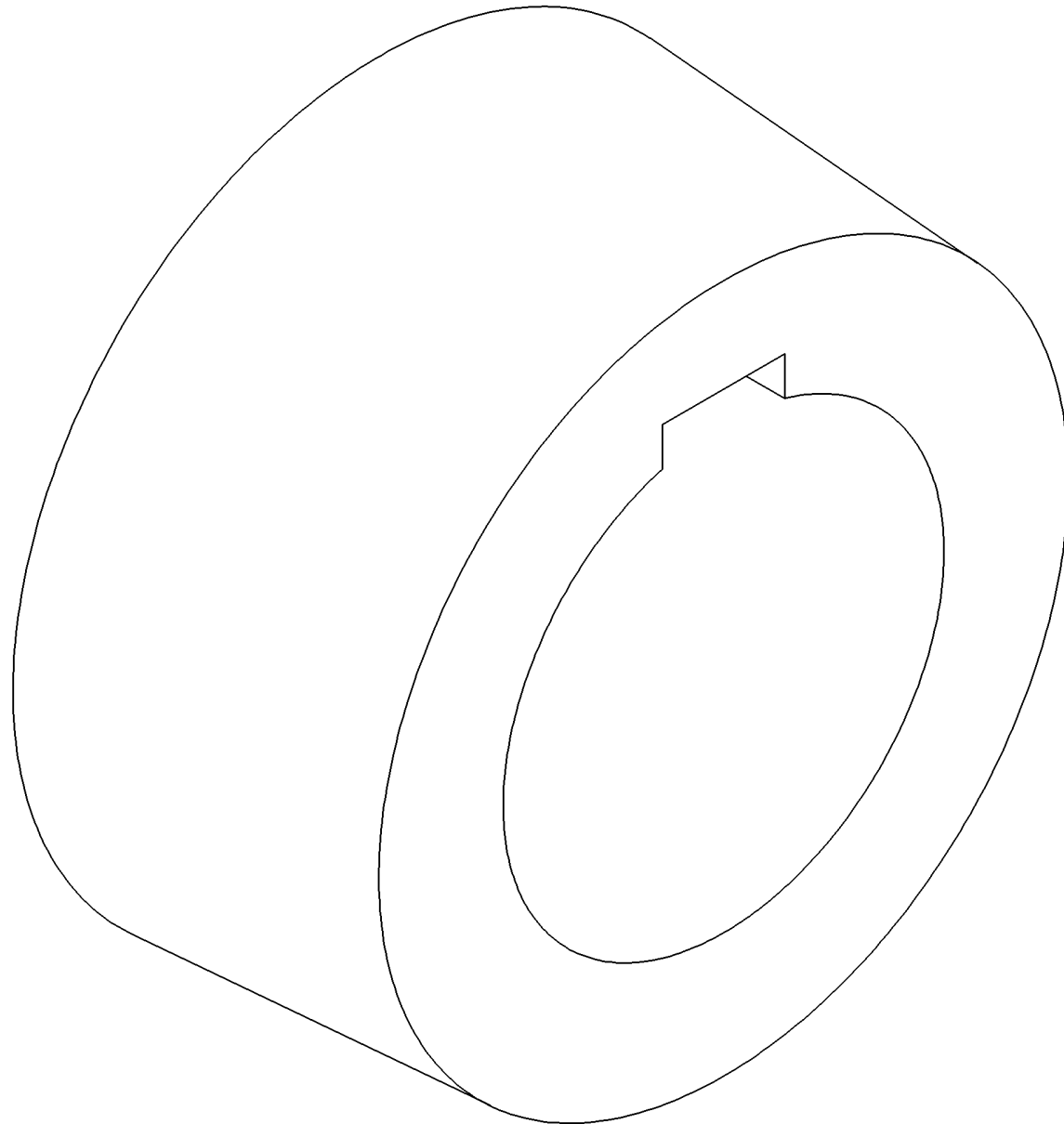

TAPERLOCK 3020 D65 - TAPERLOCK-BUSHING D 65 /3020
TAPERLOCK-BUSHING D 65 /3020 - 49.65.3020/00

49.65.3020/00

Stücklistennummer / Piece Number / Liste de Pièces / Номер



Pos.	Bestell-Nr. Stock Number Numéro de Commande Номер товара	Menge Amount Quantité Количество	Beschreibung	Description	Description	Описание
------	---	---	--------------	-------------	-------------	----------

10	49.1.3020	2,000	INBUSSCHRAUBE	SOCKET SCREW	SOCKET SCREW	
----	-----------	-------	---------------	--------------	--------------	--

KEILRIEMENSATZ KEILRIEMEN B17 1700 LW - POWERBELT SET
POWERBELT SET - 450.02.03.10.00/00

450.02.03.10.00/00
Stücklistennummer / Piece Number / Liste de Pièces / Номер



Pos.	Bestell-Nr. Stock Number Numéro de Commande Номер товара	Menge Amount Quantité Количество	Beschreibung	Description	Description	Описание
------	---	---	--------------	-------------	-------------	----------

10	 50.1.1740.B.X	3,000	KEILRIEMEN B17 1700 LW	POWERBELT REINFORCED	POWERBELT REINFORCED	
----	---	-------	------------------------	----------------------	----------------------	--

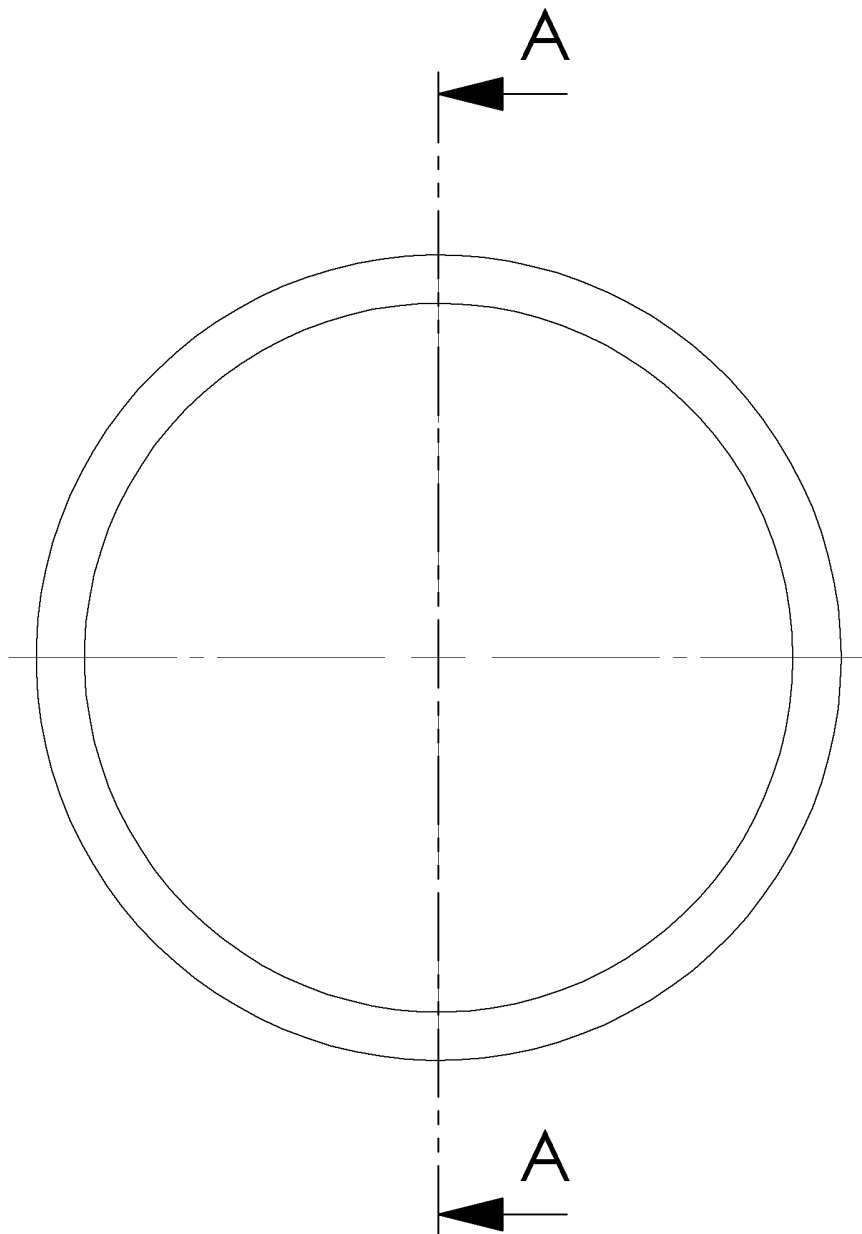

DISTANZRING D75X4,5X4 - DISTANCE RING
DISTANCE RING - 754.20.5.02/A

754.20.5.02/A
Stücklistennummer / Piece Number / Liste de Pièces / Номер



Pos.	Bestell-Nr. Stock Number Numéro de Commande Номер товара	Menge Amount Quantité Количество	Beschreibung	Description	Description	Описание
------	---	---	--------------	-------------	-------------	----------

10	 18.065.085.2	2,000	PASSSCHEIBE 65X85X2 GEOELT	ADJUSTING WASHER 65X85X2	ADJUSTING WASHER 65X85X2	
----	--	-------	----------------------------	--------------------------	--------------------------	--

DISTANZRING D75X4,5X4 - DISTANCE RING
DISTANCE RING - 754.20.5.02/A

754.20.5.02/A
Stücklistennummer / Piece Number / Liste de Pièces / Homep

Pinoth[®]

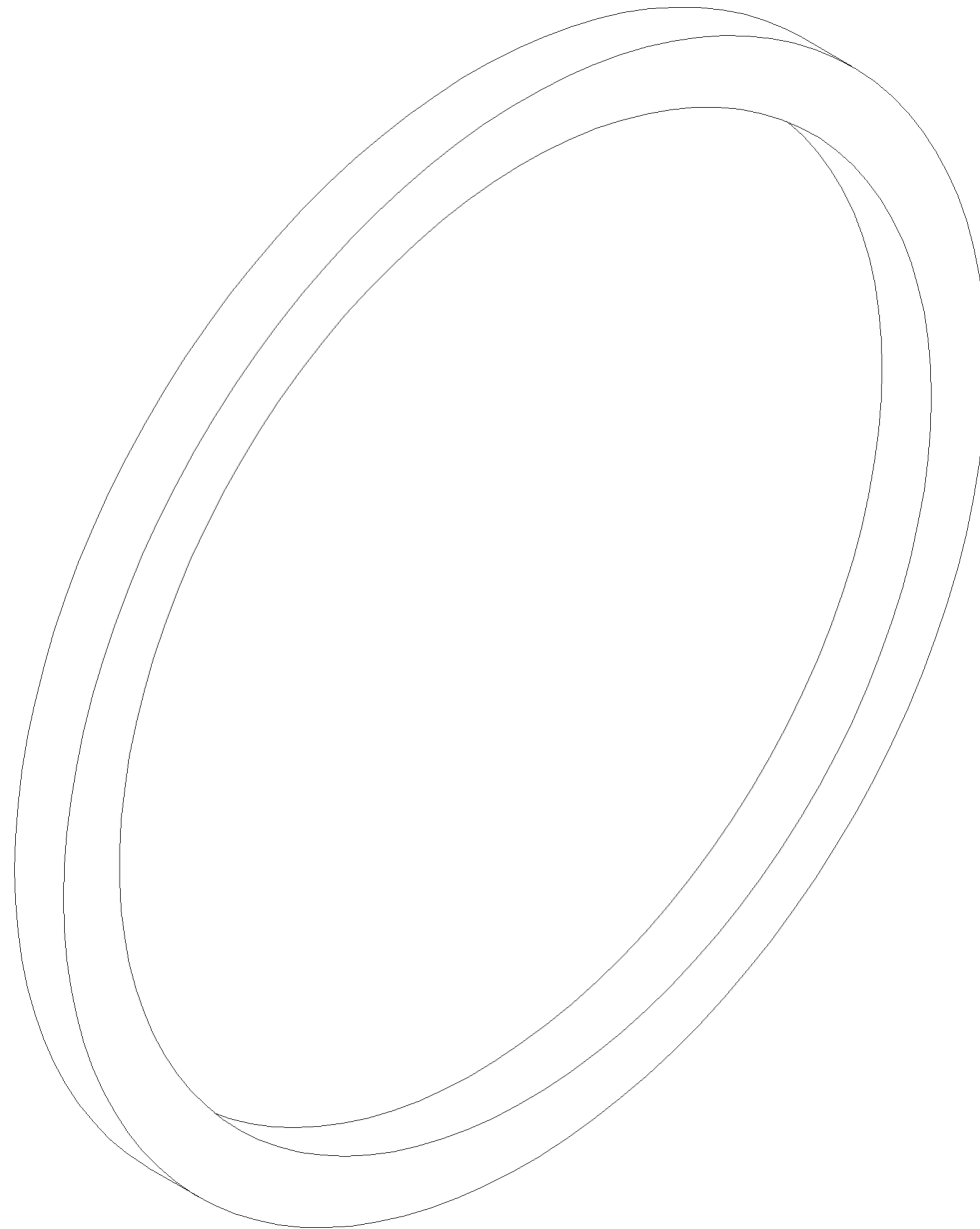

DISTANZRING D75X4,5X4 - DISTANCE RING
DISTANCE RING - 754.20.5.02/A

754.20.5.02/A
Stücklistennummer / Piece Number / Liste de Pièces / Номер



Pos.	Bestell-Nr. Stock Number Numéro de Commande Номер товара	Menge Amount Quantité Количество	Beschreibung	Description	Description	Описание
------	---	---	--------------	-------------	-------------	----------

10	 18.065.085.2	2,000	PASSSCHEIBE 65X85X2 GEOELT	ADJUSTING WASHER 65X85X2	ADJUSTING WASHER 65X85X2	
----	--	-------	----------------------------	--------------------------	--------------------------	--

DISTANZRING D75X4,5X9 - DISTANCE RING
DISTANCE RING - 796.6.2.65/B

796.6.2.65/B
Stücklistennummer / Piece Number / Liste de Pièces / Homep

Pinoth[®]

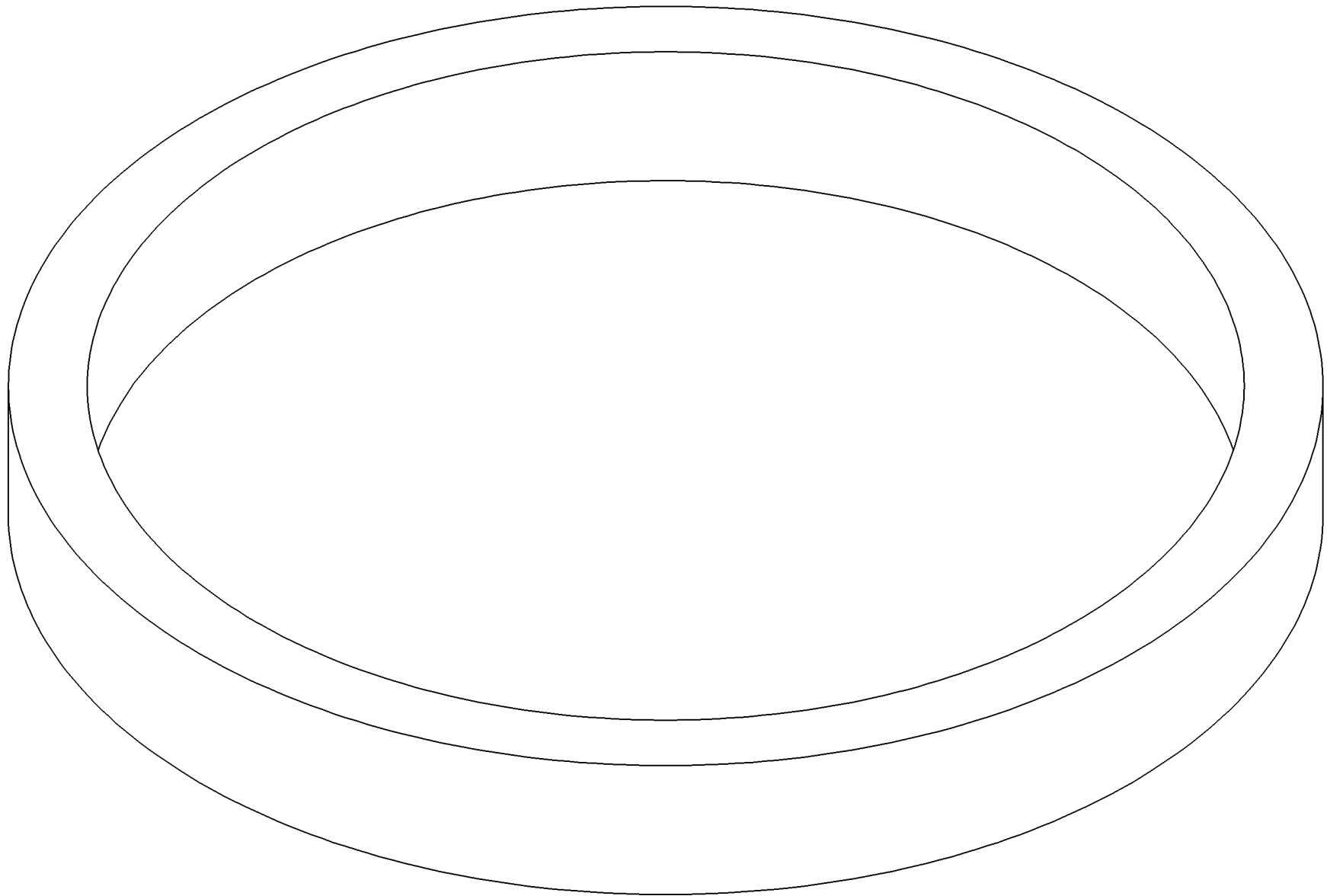

DISTANZRING D75X4,5X9 - DISTANCE RING
DISTANCE RING - 796.6.2.65/B

796.6.2.65/B
Stücklistennummer / Piece Number / Liste de Pièces / Номер



Pos.	Bestell-Nr. Stock Number Numéro de Commande Номер товара	Menge Amount Quantité Количество	Beschreibung	Description	Description	Описание
------	---	---	--------------	-------------	-------------	----------

20	 18.065.085.2	2,000	PASSSCHEIBE 65X85X2 GEOELT	ADJUSTING WASHER 65X85X2	ADJUSTING WASHER 65X85X2	
----	--	-------	----------------------------	--------------------------	--------------------------	--

DISTANZRING D75X4,5X9 - DISTANCE RING
DISTANCE RING - 796.6.2.65/B

796.6.2.65/B
Stücklistennummer / Piece Number / Liste de Pièces / Homep

Pinoth[®]

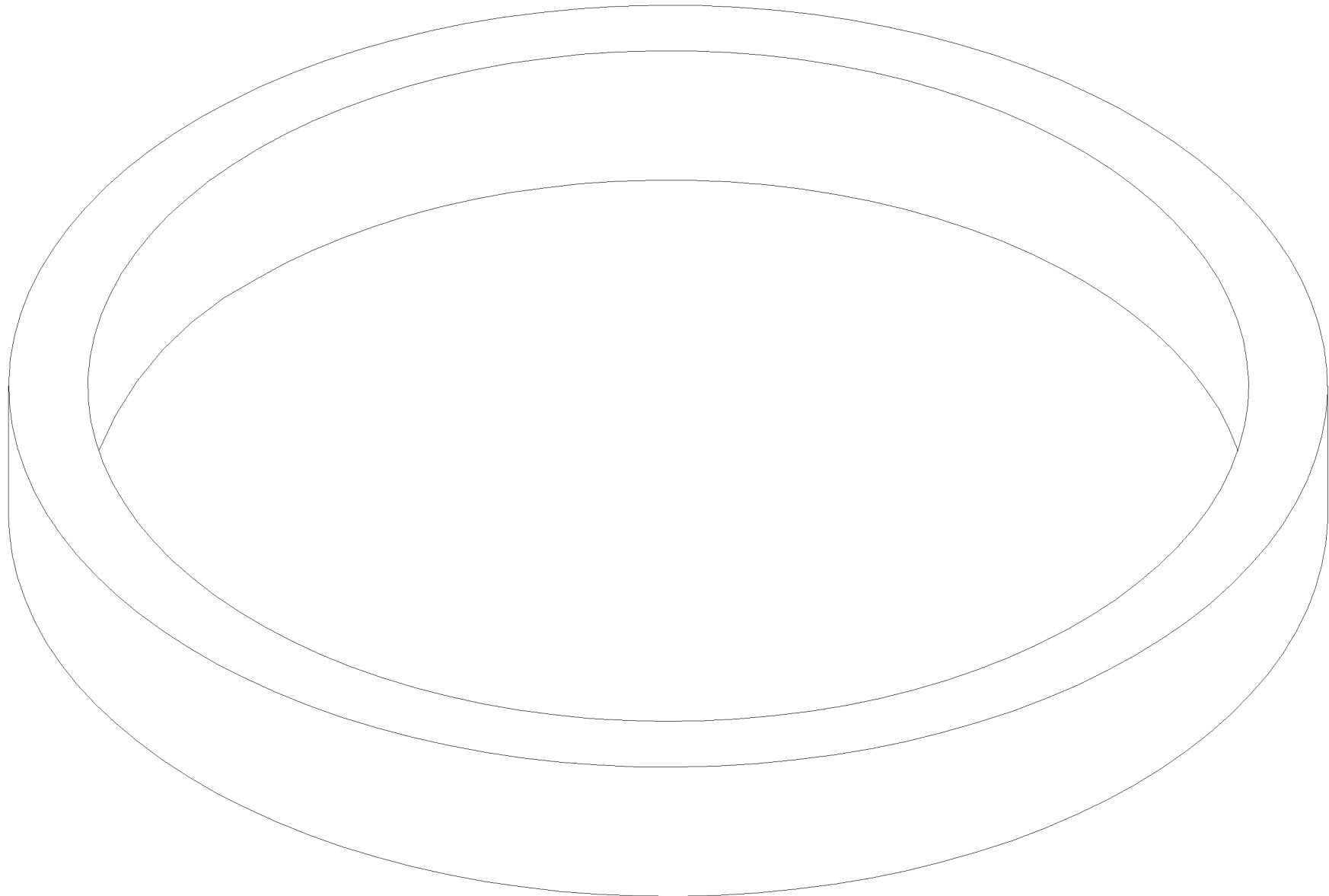

DISTANZRING D75X4,5X9 - DISTANCE RING
DISTANCE RING - 796.6.2.65/B

796.6.2.65/B
Stücklistennummer / Piece Number / Liste de Pièces / Номер



Pos.	Bestell-Nr. Stock Number Numéro de Commande Номер товара	Menge Amount Quantité Количество	Beschreibung	Description	Description	Описание
------	---	---	--------------	-------------	-------------	----------

20	 18.065.085.2	2,000	PASSSCHEIBE 65X85X2 GEOELT	ADJUSTING WASHER 65X85X2	ADJUSTING WASHER 65X85X2	
----	--	-------	----------------------------	--------------------------	--------------------------	--

GEHAEUSE M450E - 1100 GESCHRAUBT - GEHAEUSE M450E - 1100 GESCHRAUBT
GEHAEUSE M450E - 1100 GESCHRAUBT - 470.01.00.00.00/02

470.01.00.00.00/02

Stücklistennummer / Piece Number / Liste de Pièces / Homep



Pos.		Bestell-Nr. Stock Number Numéro de Commande Номер товара	Menge Amount Quantité Количество	Beschreibung	Description	Description	Описание
1		470.01.19.00.00/00	1,000	<u>KETTENVORHANG</u>	KETTENVORHANG	KETTENVORHANG	
2		41386156/00	1,000	<u>DECKEL-GESCHRAUBT M450</u>	COVER-SCREWED M450	COUVERCLE-VISSE M450	
3		470.01.12.00.00/00	1,000	<u>GEGENSCHNEIDEN</u>	GEGENSCHNEIDEN	GEGENSCHNEIDEN	
4		470.01.16.00.00/00	1,000	<u>DECKEL ROTORLAGER</u>	DECKEL ROTORLAGER	DECKEL ROTORLAGER	
5		470.01.17.00.00/00	1,000	<u>DECKEL SEITENABDECKUNG</u>	DECKEL SEITENABDECKUNG	DECKEL SEITENABDECKUNG	
6		470.01.18.00.00/00	1,000	<u>DECKEL VORNE</u>	DECKEL VORNE	DECKEL VORNE	
7		470.01.01.00.00/C	1,000	<u>GEHAEUSE M450E - 1100 GESCHWEISST</u>	GEHAEUSE M450E - 1100 GESCHWEISST	GEHAEUSE M450E - 1100 GESCHWEISST	
8		470.01.01.02.00/00	1,000	<u>ADAPTER VORNE</u>	ADAPTER VORNE	ADAPTER VORNE	
9		470.01.01.01.00/00	1,000	<u>ADAPTER HINTEN</u>	ADAPTER HINTEN	ADAPTER HINTEN	
11		453.01.03.00.00/00	1,000	ROTORSCHLITZABDECKUNG	ROTORSCHLITZABDECKUNG	ROTORSCHLITZABDECKUNG	
12		470.01.03.00.01/00	1,000	ROTORSCHLITZABDECKUNG	ROTORSCHLITZABDECKUNG	ROTORSCHLITZABDECKUNG	

GEHAEUSE M450E - 1100 GESCHRAUBT - GEHAEUSE M450E - 1100 GESCHRAUBT
GEHAEUSE M450E - 1100 GESCHRAUBT - 470.01.00.00.00/02

470.01.00.00.00/02

Stücklistennummer / Piece Number / Liste de Pièces / Homep



Pos.		Bestell-Nr. Stock Number Numéro de Commande Номер товара	Menge Amount Quantité Количество	Beschreibung	Description	Description	Описание
13		01.10.20055	4,000	SKT-SCHRAUBE M20X55 8.8	SCREW M20X55 DIN 933	SCREW M20X55 DIN 933	
14		01.10.20040	20,0-00	SKT-SCHRAUBE M20X40 8.8	SCREW M20X40 DIN 933	SCREW M20X40 DIN 933	
15		05.01.21	24,0-00	SCHEIBE ISO 7090-21-200HV	WASHER B21 DIN 125 GALVANIZED	WASHER B21 DIN 125 GALVANIZED	

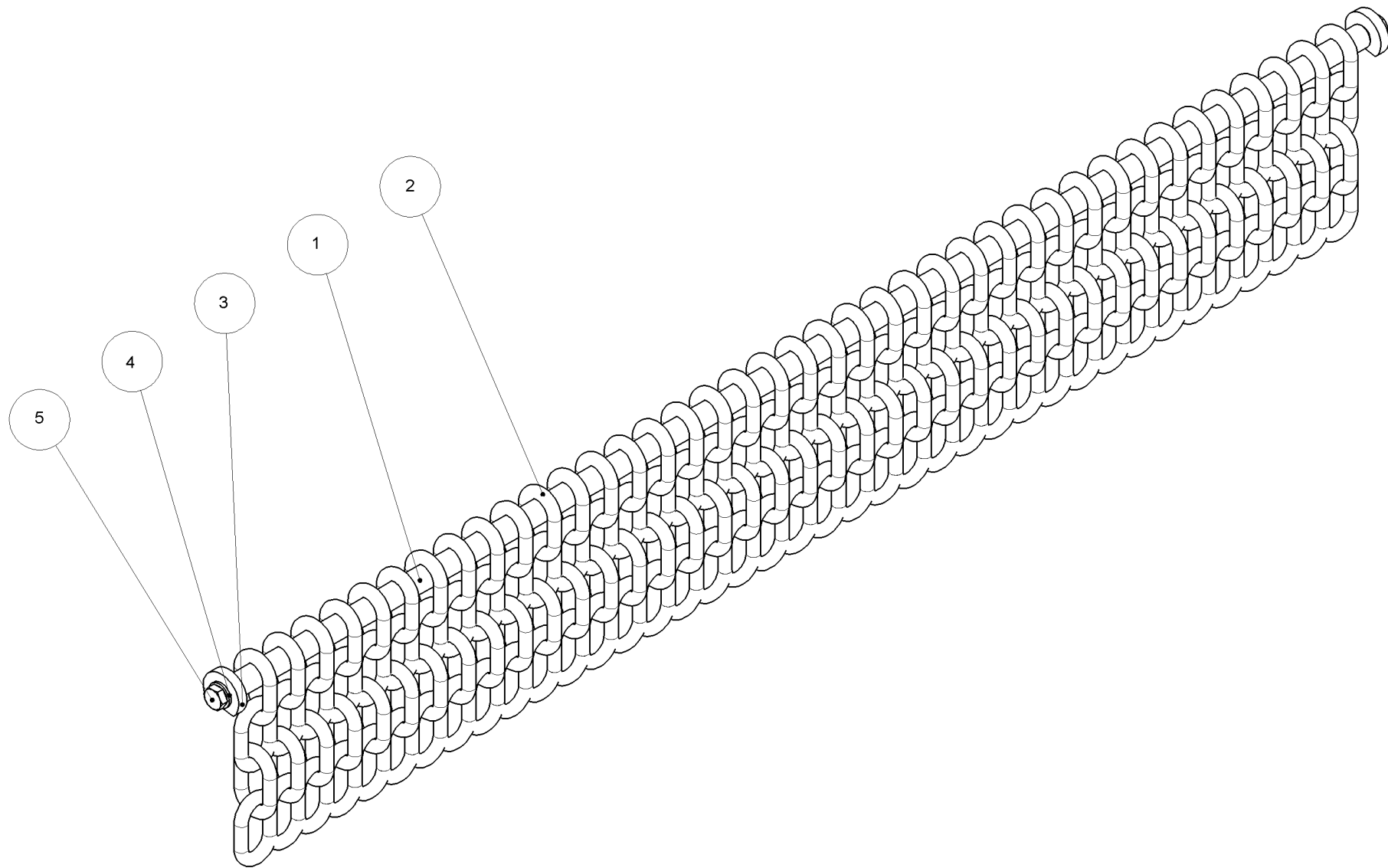

KETTENVORHANG - KETTENVORHANG
 KETTENVORHANG - 470.01.19.00.00/00

470.01.19.00.00/00
 Stücklistennummer / Piece Number / Liste de Pièces / Номер



Pos.		Bestell-Nr. Stock Number Numéro de Commande Номер товара	Menge Amount Quantité Количество	Beschreibung	Description	Description	Описание
10		740.01.19.00.01/00	1,000	STANGE KETTENVORHANG	STANGE KETTENVORHANG	STANGE KETTENVORHANG	
20		42.10.40.04/00	39,0- 00	RUNDSTAHLKETTE 10X40 4 GLI. FORM G	RUNDSTAHLKETTE 10X40 4 GLI. FORM G	RUNDSTAHLKETTE 10X40 4 GLI. FORM G	
30		470.01.19.00.01/00	2,000	SCHEIBE	SCHEIBE	SCHEIBE	
40		05.01.10	2,000	SCHEIBE ISO 7090-10-200HV	WASHER B10,5 DIN 125 GALV.	WASHER B10,5 DIN 125 GALV.	
50		01.10.10025	2,000	SKT-SCHRAUBE M10X25 8.8	SCREW M10X25 DIN 933	SCREW M10X25 DIN 933	

DECKEL-GESCHRAUBT M450 - COVER-SCREWED M450
COUVERCLE-VISSE M450 - 41386156/00

41386156/00







Stücklistennummer / Piece Number / Liste de Pièces / Homep



DECKEL-GESCHRAUBT M450 - COVER-SCREWED M450
 COUVERCLE-VISSE M450 - 41386156/00

41386156/00
 Stücklistennummer / Piece Number / Liste de Pièces / Номер



Pos.		Bestell-Nr. Stock Number Numéro de Commande Номер товара	Menge Amount Quantité Количество	Beschreibung	Description	Description	Описание
1		480.01.04.20.00/01	1,000	LOGO-GESCHWEISST	LOGO-WELDED	LOGO-SOUDE	
3		729.01.16.00.01/A	1,000	DECKEL	DECKEL	DECKEL	
4		01.10.10025	8,000	SKT-SCHRAUBE M10X25 8.8	SCREW M10X25 DIN 933	SCREW M10X25 DIN 933	
5		01.10.10020	2,000	SKT-SCHRAUBE M10X20 8.8	SCREW M10X20 DIN 933	SCREW M10X20 DIN 933	
6		01.40.06016.C.V	8,000	RUNDKOPFSCHRAUBE M6X16 10.9	FILLISTER HEAD SCREW M6X16 DIN	FILLISTER HEAD SCREW M6X16 DIN	
7		05.01.10	10,0- 00	SCHEIBE ISO 7090-10-200HV	WASHER B10,5 DIN 125 GALV.	WASHER B10,5 DIN 125 GALV.	

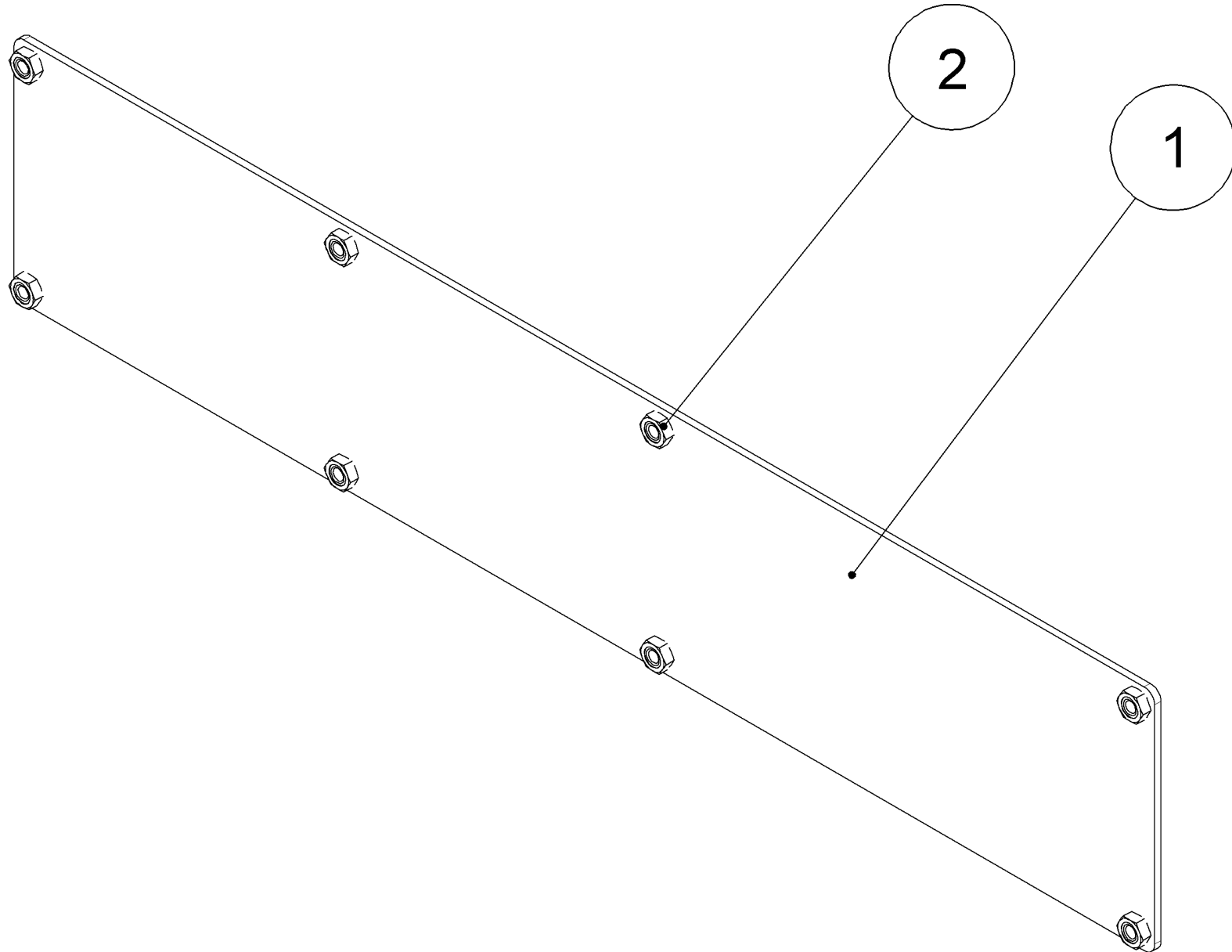

LOGO-GESCHWEISST - LOGO-WELDED
LOGO-SOUDE - 480.01.04.20.00/01

480.01.04.20.00/01
Stücklistennummer / Piece Number / Liste de Pièces / Номер



Pos.	Bestell-Nr. Stock Number Numéro de Commande Номер товара	Menge Amount Quantité Количество	Beschreibung	Description	Description	Описание
------	---	---	--------------	-------------	-------------	----------

10



480.01.04.20.01/01

1,000 BLECH-LOGO

SHEET METAL-LOGO

TOLE-LOGO

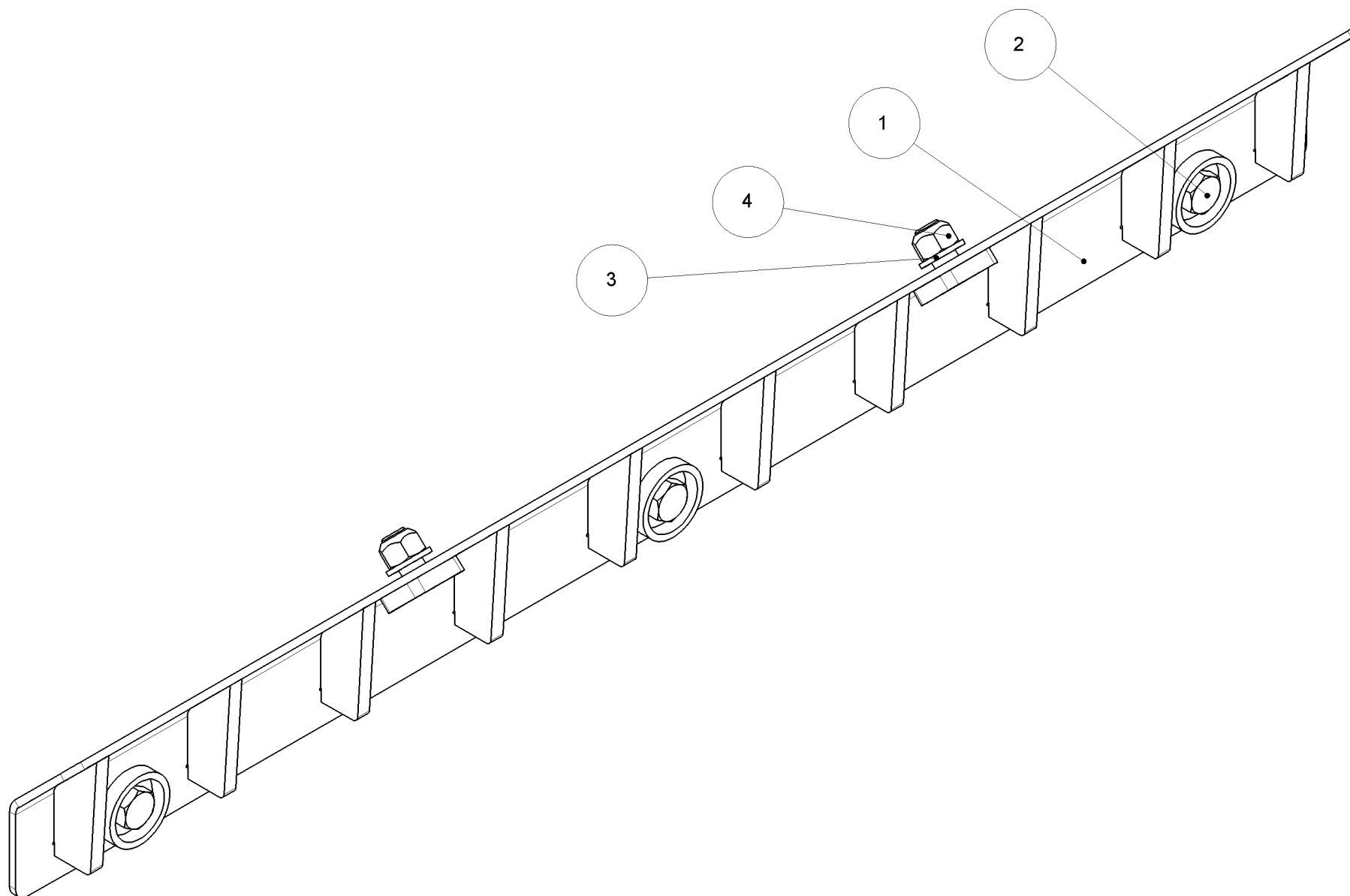

GEGENSCHNEIDEN - GEGENSCHNEIDEN
 GEGENSCHNEIDEN - 470.01.12.00.00/00

470.01.12.00.00/00
 Stücklistennummer / Piece Number / Liste de Pièces / Номер



Pos.		Bestell-Nr. Stock Number Numéro de Commande Номер товара	Menge Amount Quantité Количество	Beschreibung	Description	Description	Описание
10		470.01.10.00.00/00	1,000	GEGENSCHNEIDE GESCHWEISST	GEGENSCHNEIDE GESCHWEISST	GEGENSCHNEIDE GESCHWEISST	
20		01.10.16030	5,000	SKT-SCHRAUBE M16X30 8.8	SCREW M16X30 DIN 933	SCREW M16X30 DIN 933	
30		05.01.17	2,000	SCHEIBE ISO 7090-17-200HV	WASHER B17 DIN 125 GALVANIZED	WASHER B17 DIN 125 GALVANIZED	
40		03.02.16	2,000	SKT-MUTTER M16 8, SELBSTSICH.	NUT M16 DIN980V SELF- LOCKING	NUT M16 DIN980V SELF- LOCKING	

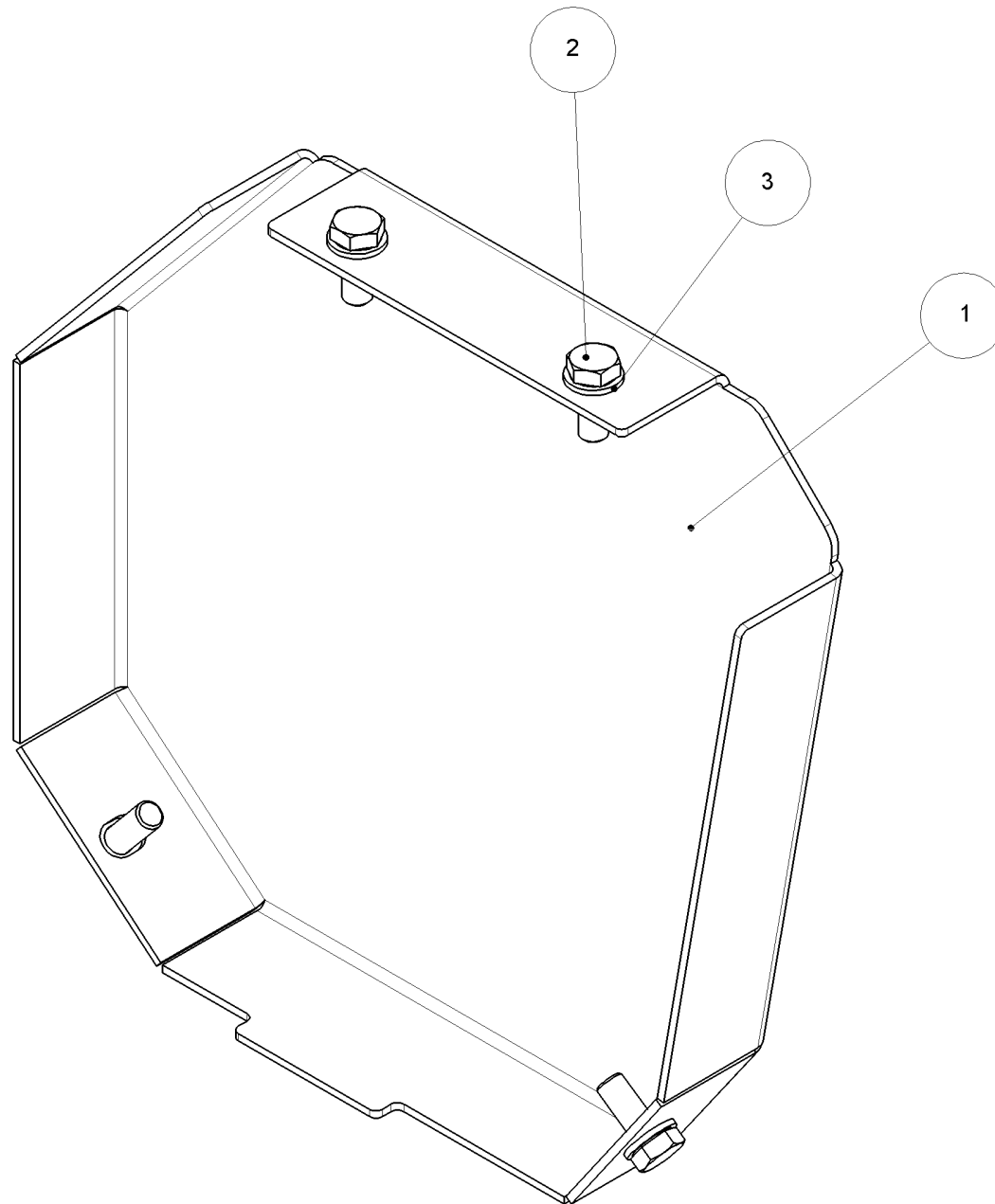

DECKEL ROTORLAGER - DECKEL ROTORLAGER
 DECKEL ROTORLAGER - 470.01.16.00.00/00

470.01.16.00.00/00
 Stücklistennummer / Piece Number / Liste de Pièces / Номер



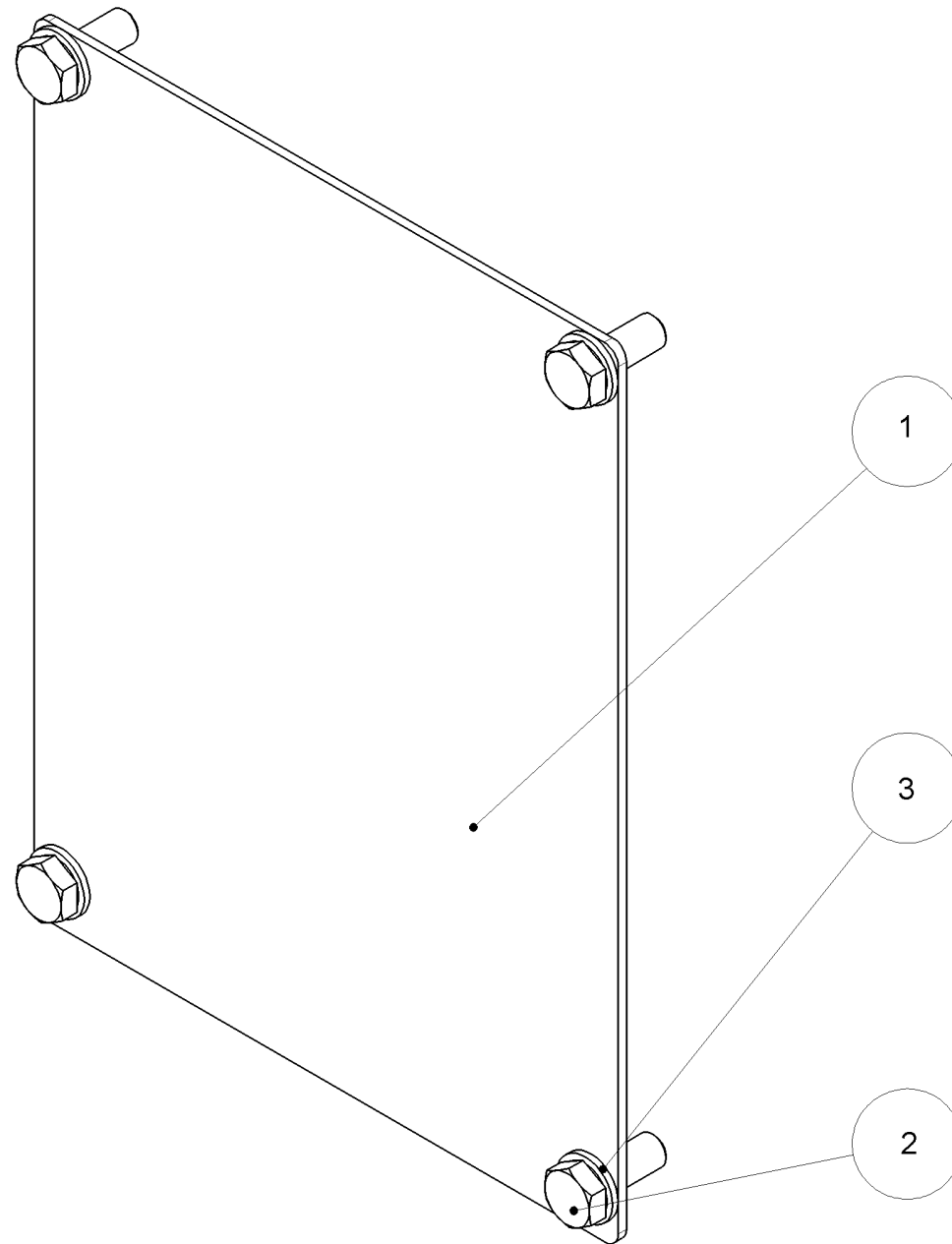

Pos.		Bestell-Nr. Stock Number Numéro de Commande Номер товара	Menge Amount Quantité Количество	Beschreibung	Description	Description	Описание
10		470.01.16.00.01/00	1,000	DECKEL	DECKEL	DECKEL	
20		01.10.10025	4,000	SKT-SCHRAUBE M10X25 8.8	SCREW M10X25 DIN 933	SCREW M10X25 DIN 933	
30		05.01.10	4,000	SCHEIBE ISO 7090-10-200HV	WASHER B10,5 DIN 125 GALV.	WASHER B10,5 DIN 125 GALV.	



DECKEL SEITENABDECKUNG - DECKEL SEITENABDECKUNG
 DECKEL SEITENABDECKUNG - 470.01.17.00.00/00

470.01.17.00.00/00
 Stücklistennummer / Piece Number / Liste de Pièces / Номер



Pos.	Bestell-Nr. Stock Number Numéro de Commande Номер товара	Menge Amount Quantité Количество	Beschreibung	Description	Description	Описание
10	 470.01.17.00.01/00	1,000	DECKEL	DECKEL	DECKEL	
20	 01.10.10025	4,000	SKT-SCHRAUBE M10X25 8.8	SCREW M10X25 DIN 933	SCREW M10X25 DIN 933	
30	 05.01.10	4,000	SCHEIBE ISO 7090-10-200HV	WASHER B10,5 DIN 125 GALV.	WASHER B10,5 DIN 125 GALV.	

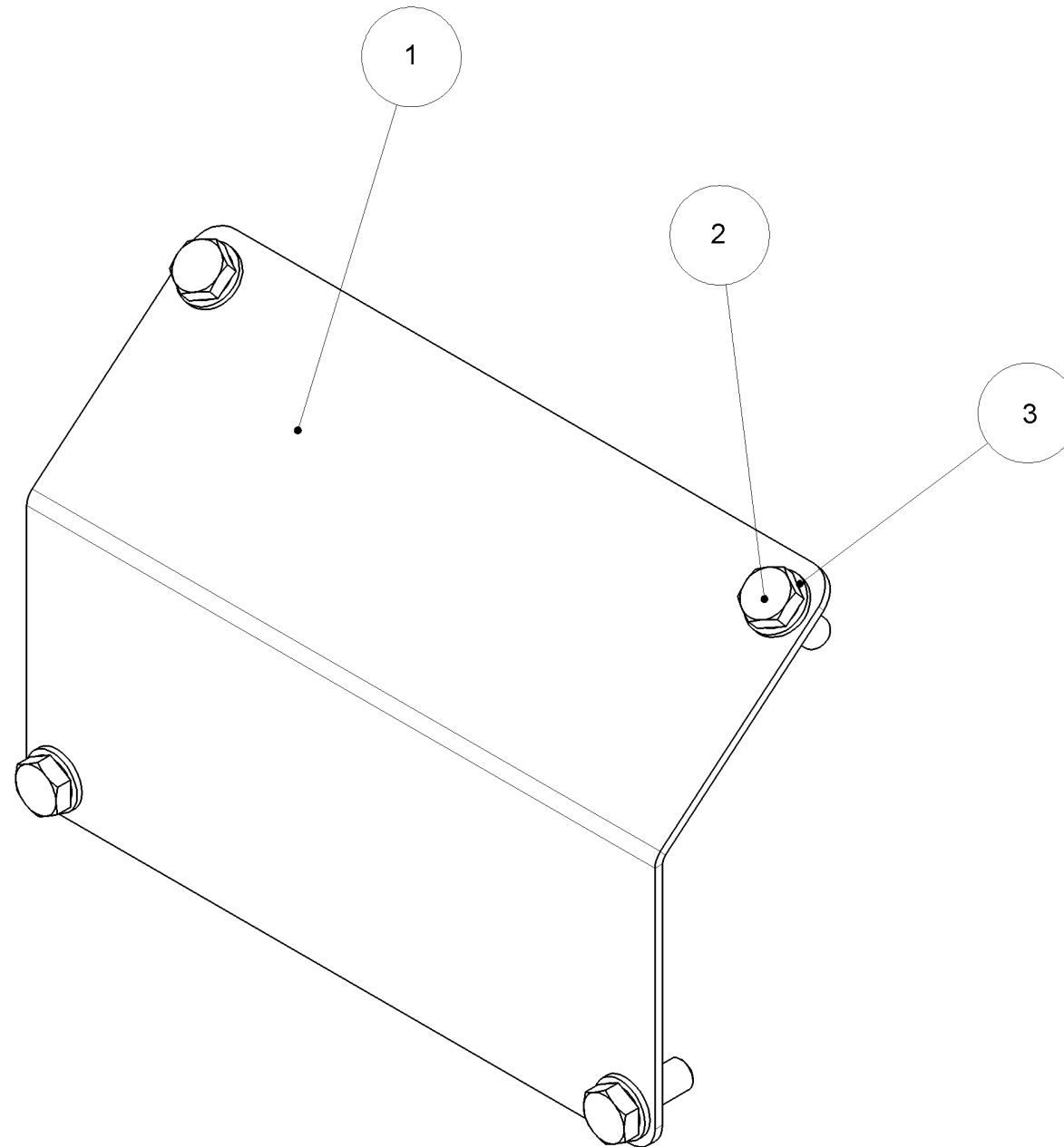





DECKEL VORNE - DECKEL VORNE
DECKEL VORNE - 470.01.18.00.00/00

470.01.18.00.00/00
Stücklistennummer / Piece Number / Liste de Pièces / Номер

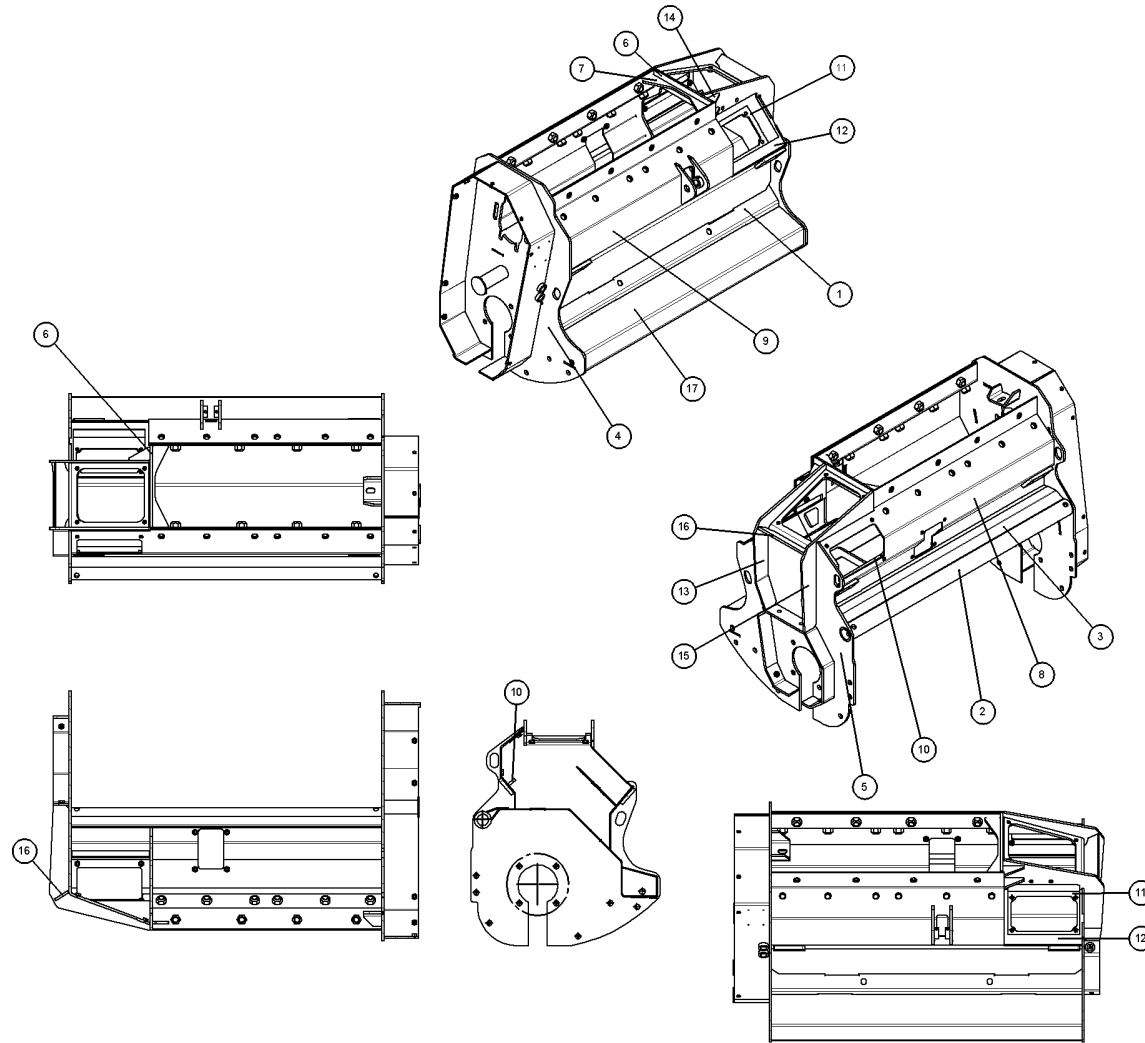

Pos.		Bestell-Nr. Stock Number Numéro de Commande Номер товара	Menge Amount Quantité Количество	Beschreibung	Description	Description	Описание
10		470.01.18.00.01/00	1,000	DECKEL VORNE	DECKEL VORNE	DECKEL VORNE	
20		01.10.10025	4,000	SKT-SCHRAUBE M10X25 8.8	SCREW M10X25 DIN 933	SCREW M10X25 DIN 933	
30		05.01.10	4,000	SCHEIBE ISO 7090-10-200HV	WASHER B10,5 DIN 125 GALV.	WASHER B10,5 DIN 125 GALV.	



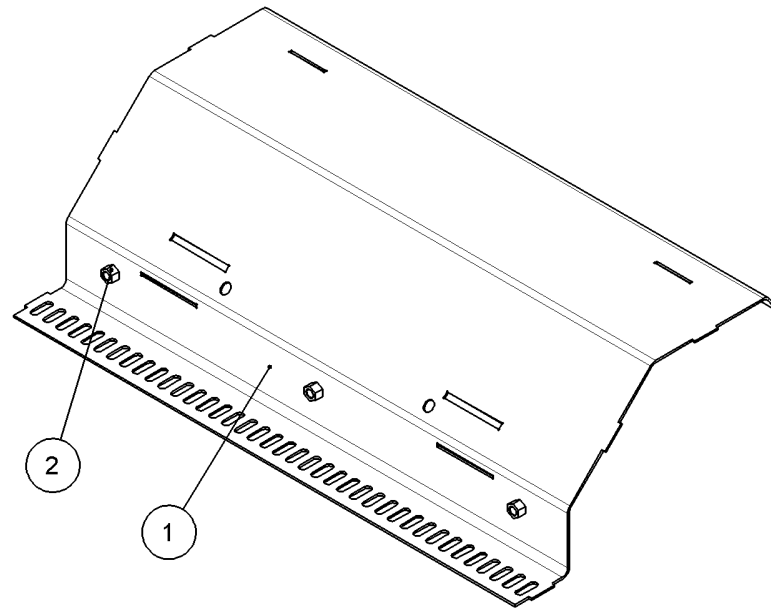

Pos.	Bestell-Nr. Stock Number Numéro de Commande Номер товара	Menge Amount Quantité Количество	Beschreibung	Description	Description	Описание
10	 470.01.01.05.00/00	1,000	<u>MANTELBLECH</u>	MANTELBLECH	MANTELBLECH	
80	 470.01.01.07.00/B	1,000	<u>FRONTBLECH</u>	FRONTBLECH	FRONTBLECH	
90	 470.01.01.08.00/01	1,000	<u>RUECKWAND</u>	RUECKWAND	RUECKWAND	





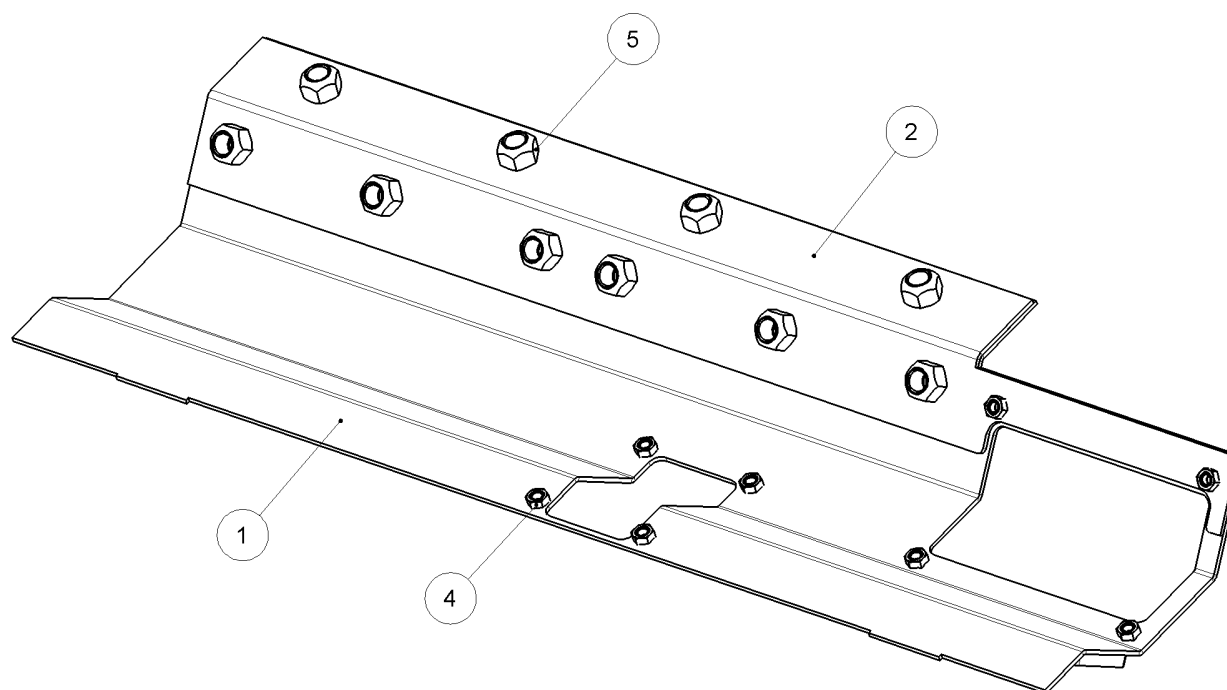
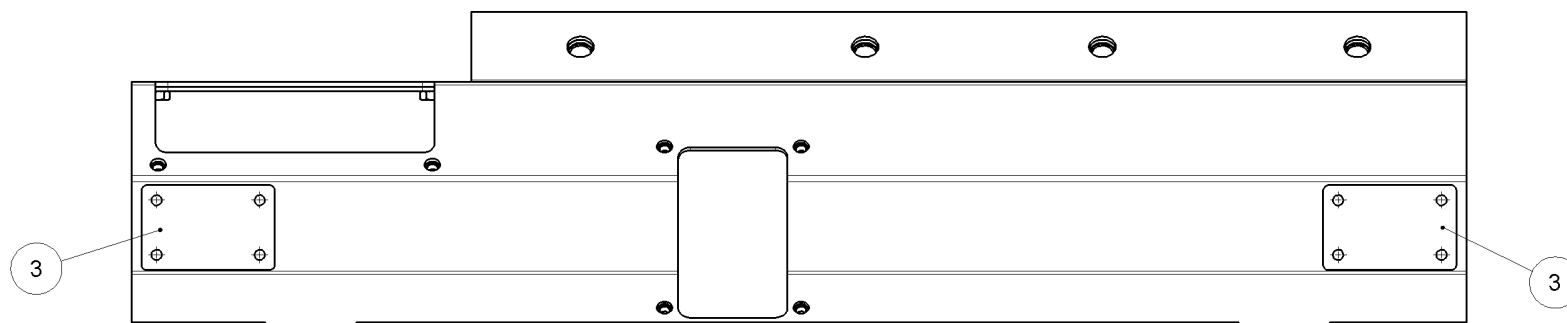

Pos.	Bestell-Nr. Stock Number Numéro de Commande Номер товара	Menge Amount Quantité Количество	Beschreibung	Description	Description	Описание
------	---	---	--------------	-------------	-------------	----------

20	 03.02.16	3,000	SKT-MUTTER M16 8, SELBSTSICH.	NUT M16 DIN980V SELF- LOCKING	NUT M16 DIN980V SELF- LOCKING	
----	--	-------	----------------------------------	----------------------------------	----------------------------------	--

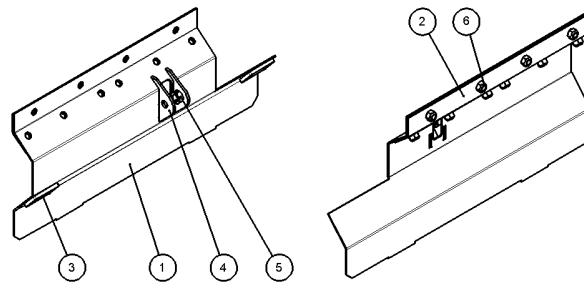

Pos.	Bestell-Nr. Stock Number Numéro de Commande Номер товара	Menge Amount Quantité Количество	Beschreibung	Description	Description	Описание
50	 03.02.20	10,0-00	SKT-MUTTER M20 8, SELBSTSICH.	NUT M20 DIN980V SELF-LOCKING	NUT M20 DIN980V SELF-LOCKING	



Pos.		Bestell-Nr. Stock Number Numéro de Commande Номер товара	Menge Amount Quantité Количество	Beschreibung	Description	Description	Описание
50		08.01.25.16/00	2,000	STELLRING 25,2X40X16X8	ADJUSTING COLLAR 25,2X40X16X8	ADJUSTING COLLAR 25,2X40X16X8	
60		03.02.20	10,0- 00	SKT-MUTTER M20 8, SELBSTSICH.	NUT M20 DIN980V SELF- LOCKING	NUT M20 DIN980V SELF- LOCKING	

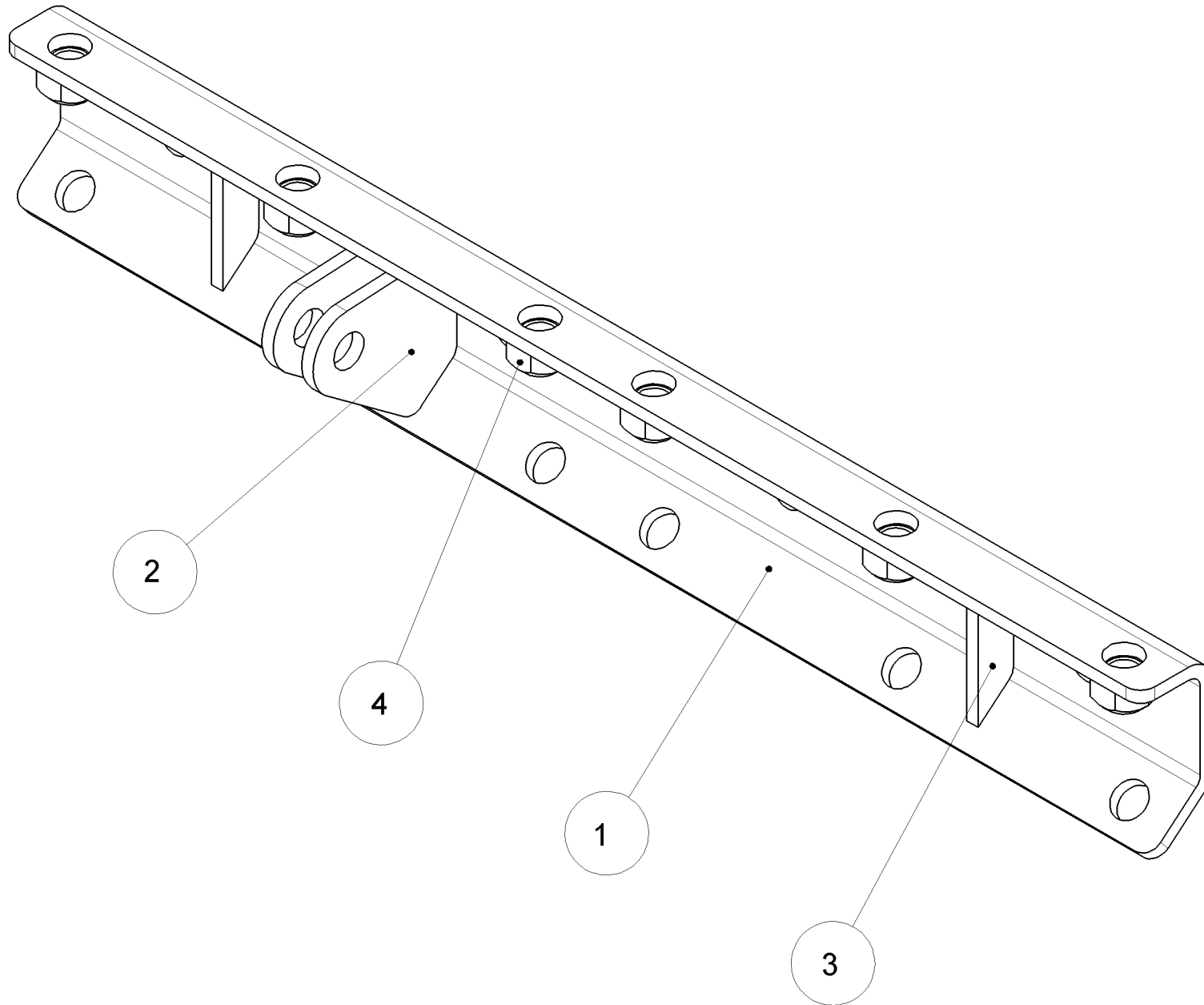

ADAPTER VORNE - ADAPTER VORNE
ADAPTER VORNE - 470.01.01.02.00/00

470.01.01.02.00/00
Stücklistennummer / Piece Number / Liste de Pièces / Номер



Pos.	Bestell-Nr. Stock Number Numéro de Commande Номер товара	Menge Amount Quantité Количество	Beschreibung	Description	Description	Описание
------	---	---	--------------	-------------	-------------	----------

40	 03.02.20	6,000	SKT-MUTTER M20 8, SELBSTSICH.	NUT M20 DIN980V SELF- LOCKING	NUT M20 DIN980V SELF- LOCKING	
----	--	-------	----------------------------------	----------------------------------	----------------------------------	--

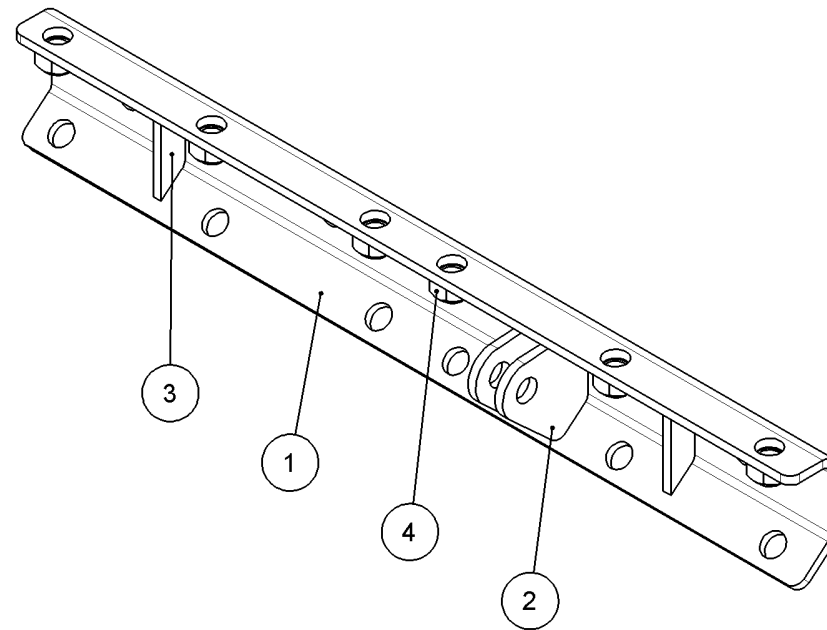

ADAPTER HINTEN - ADAPTER HINTEN
ADAPTER HINTEN - 470.01.01.01.00/00









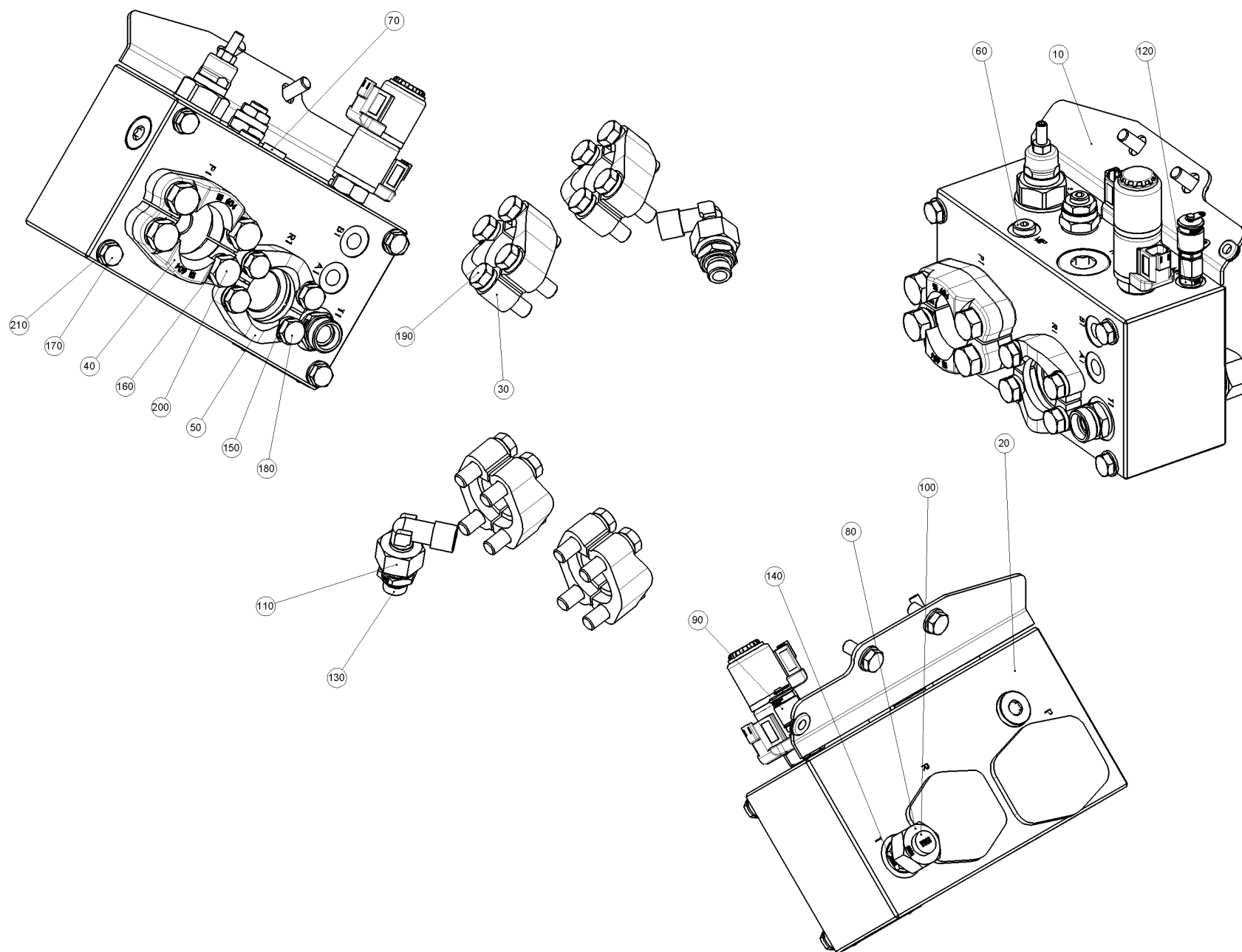



470.01.01.01.00/00
Stücklistennummer / Piece Number / Liste de Pièces / Номер











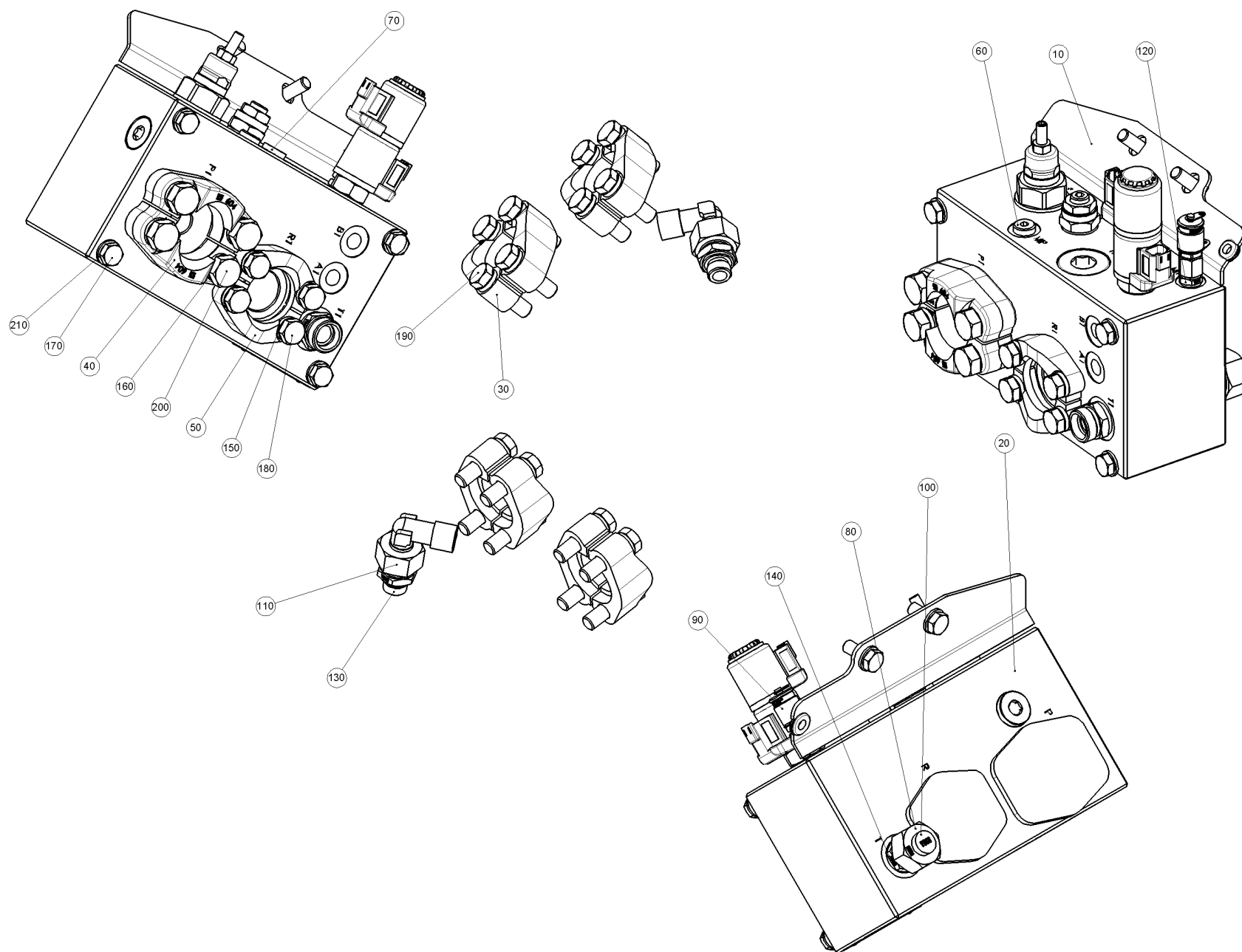

Pos.	Bestell-Nr. Stock Number Numéro de Commande Номер товара	Menge Amount Quantité Количество	Beschreibung	Description	Description	Описание
------	---	---	--------------	-------------	-------------	----------

40	 03.02.20	6,000	SKT-MUTTER M20 8, SELBSTSICH.	NUT M20 DIN980V SELF- LOCKING	NUT M20 DIN980V SELF- LOCKING	
----	--	-------	----------------------------------	----------------------------------	----------------------------------	--



Pos.		Bestell-Nr. Stock Number Numéro de Commande Номер товара	Menge Amount Quantité Количество	Beschreibung	Description	Description	Описание
10		470.01.21.00.00/00	1,000	DECKEL	DECKEL	DECKEL	
20		20.60.065/00	1,000	ANSCHLUSSBLOCK	CONNECTION BLOCK	BLOC DE LIAISON	
30		20.29.001/00	2,000	SAE-HALBFLANSCH 1 6000 PSI	SAE-HALF FLANGE 1"	SAE-HALF FLANGE 1"	
40		20.29.005/A	1,000	SAE-HALBFLANSCH 1 1/4 6000 PSI	SAE-HALBFLANSCH 1 1/4 6000 PSI	SAE-HALBFLANSCH 1 1/4 6000 PSI	
50		20.29.002/00	1,000	SAE-HALBFLANSCH 1 1/4 3000 PSI M12	SAE-HALF FLANGE 1 1/4"	SAE-HALF FLANGE 1 1/4"	
60		20.VS12.1.5/00	1,000	VERSCHLUSSSCHRAUBE M12X1,5 PN400, I-SW6	LOCK SCREW M12X1,5	LOCK SCREW M12X1,5	
70		20.VS14.1.5/00	1,000	VERSCHLUSSSCHRAUBE M14X1,5 PN400, I-SW6	LOCK SCREW M14X1,5	LOCK SCREW M14X1,5	
80		20.UEM18L/00	1,000	UEBERWURFMUTTER 18L M26X1,5 PN400, SW32	UNION NUT 18L M26-1.5	UNION NUT 18L M26-1.5	
90		20.41.001/00	1,000	PRUEFANSCHLUSS MINIMESS 8L SMK 20	FITTING MEASUREMENT 8L/ SMK20	FITTING MEASUREMENT 8L/ SMK20	
100		20.BUZ18L/00	1,000	VERSCHLUSSSTOPFEN 18L PN400 SW32	FITTING FOR MEASURE 18L C/ NUT	FITTING FOR MEASURE 18L C/ NUT	
110		20.EWV18L/00	1,000	EINSTELLBARE-VERSCHR. EW 18L PN400	HYDR. FITTING EWV 18L	HYDR. FITTING EWV 18L	



Pos.	Bestell-Nr. Stock Number Numéro de Commande Номер товара	Menge Amount Quantité Количество	Beschreibung	Description	Description	Описание
120	 20.GEV08L.M12-1.5/00	1,000	GER-EINSCHR-VERSCHR. 8L	MALE STUD COUPLING 08L M12-1.5	MALE STUD COUPLING 08L M12-1.5	
130	 20.GEV18L.M18-1.5/00	1,000	GER-EINSCHR-VERSCHR. 18L	STRAIGHT TUBE FITT. 18L18X1,5	STRAIGHT TUBE FITT. 18L18X1,5	
140	 20.GEV18L.M22-1.5/00	2,000	GER-EINSCHR-VERSCHR. 18L	STRAIGHT SCREW FIT. 18L 22X1,5	STRAIGHT SCREW FIT. 18L 22X1,5	
150	 07.02.12	12,0- 00	NORD-LOCK-SCHEIBE FUER M12	NORD-LOCK-DISC FOR M12	NORD-LOCK-DISC FOR M12	
160	 07.02.14	4,000	NORD-LOCK-SCHEIBE FUER M14	NORD-LOCK-DISC FOR M14	NORD-LOCK-DISC FOR M14	
170	 01.10.10020	4,000	SKT-SCHRAUBE M10X20 8.8	SCREW M10X20 DIN 933	SCREW M10X20 DIN 933	
190	 01.10.12045.C.V	8,000	SKT-SCHRAUBE M12X45 10.9	SCREW M12X45	SCREW M12X45	
200	 01.10.14050.C	4,000	SKT-SCHRAUBE M14X50 10.9 VERGUETET	SKT-SCHRAUBE M14X50 10.9 VERGUETET	SKT-SCHRAUBE M14X50 10.9 VERGUETET	
210	 05.01.10	4,000	SCHEIBE ISO 7090-10-200HV	WASHER B10,5 DIN 125 GALV.	WASHER B10,5 DIN 125 GALV.	
220	20.02.00576/00	1,000	HYDRAULIKSCHLAUCH	HYDRAULIC HOSE	BOYAU HYDRAULIQUE	
230	 20.02.00578/00	1,000	HYDRAULIKSCHLAUCH	HYDRAULIC HOSE	BOYAU HYDRAULIQUE	

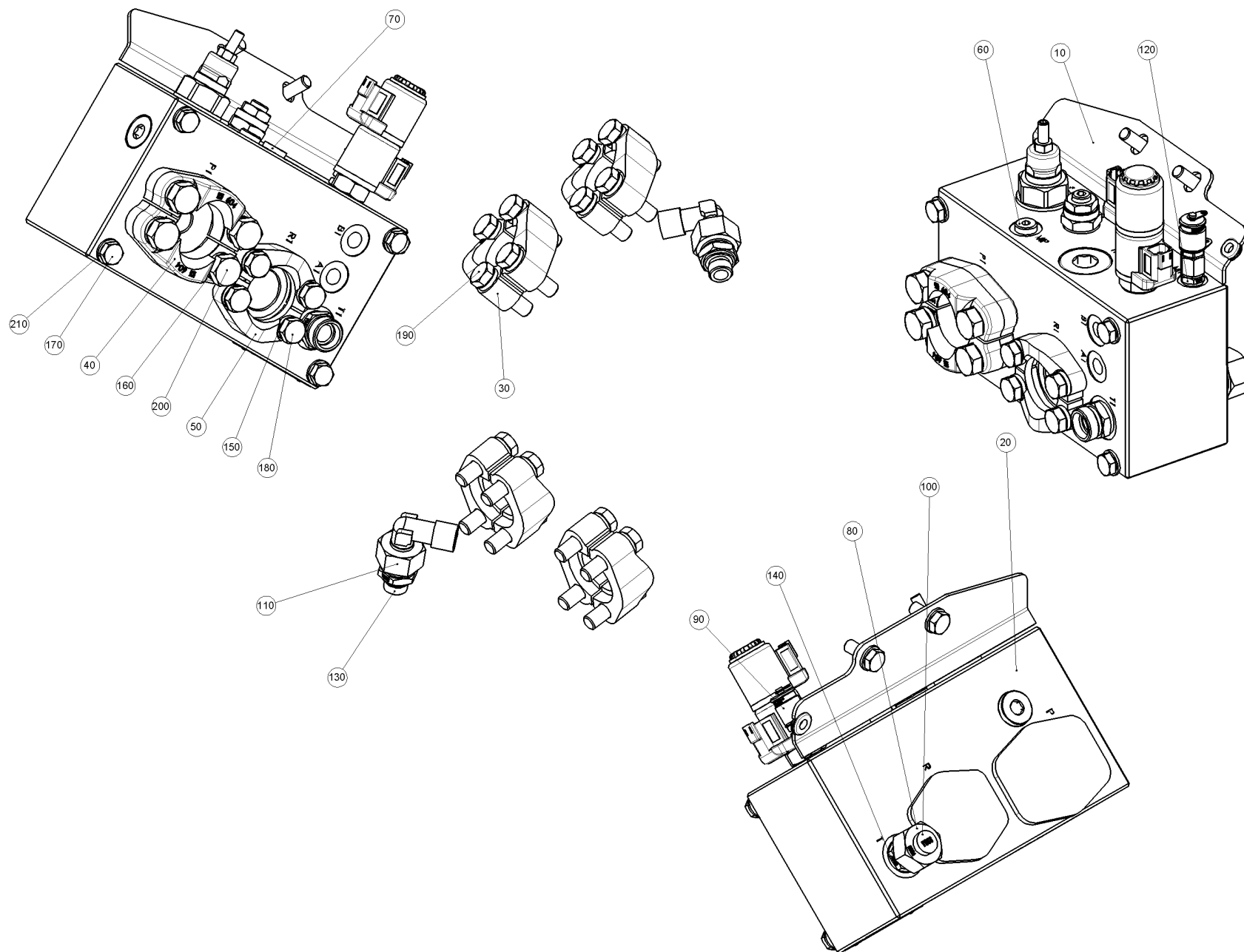



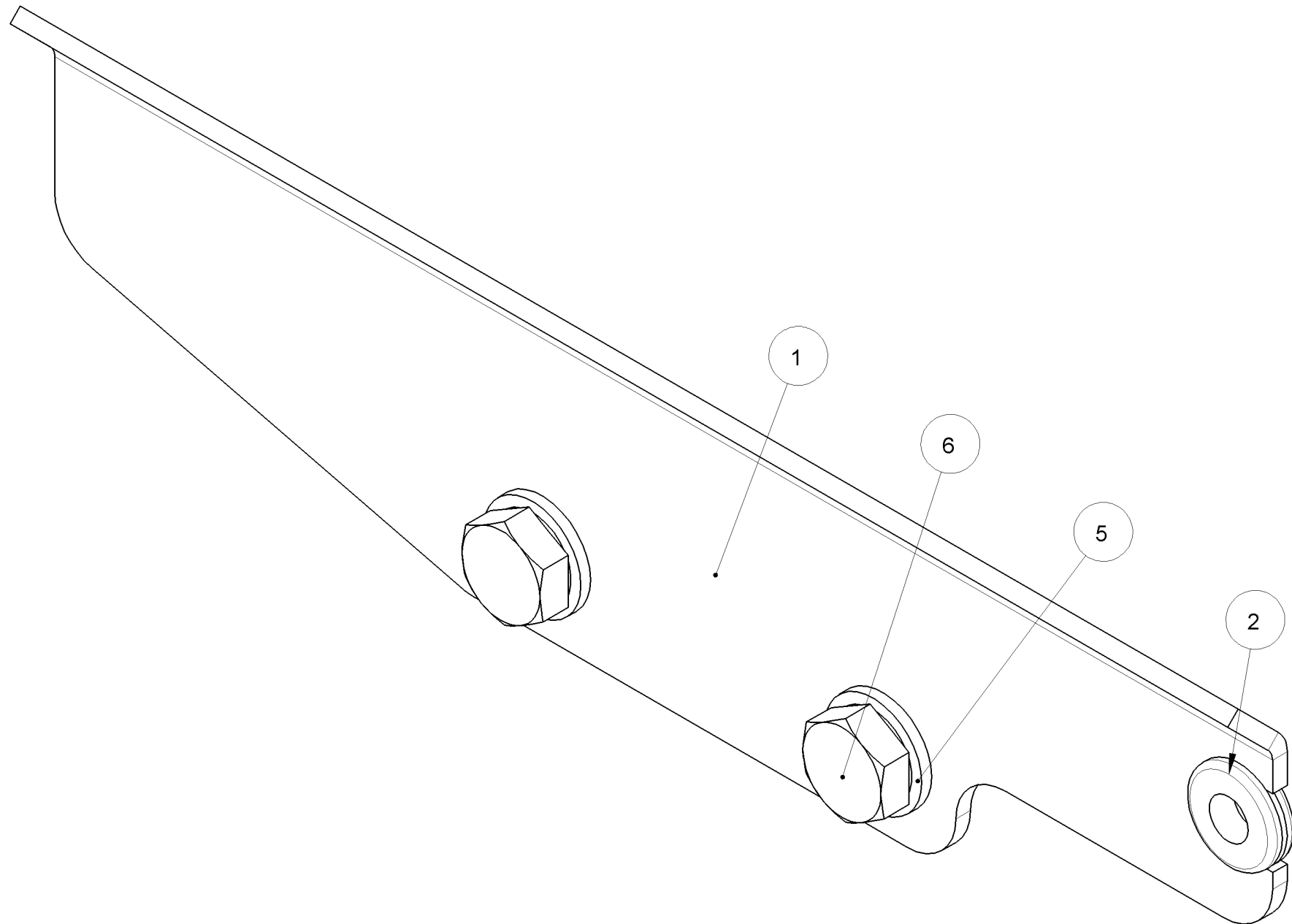

Pos.	Bestell-Nr. Stock Number Numéro de Commande Номер товара	Menge Amount Quantité Количество	Beschreibung	Description	Description	Описание
240	 20.02.14.18.0800.B/00	1,000	HYDRAULIKSCHLAUCH	HYDRAULIC HOSE	BOYAU HYDRAULIQUE	
250	28031942/00	2,000	MAGNETSPULE 12V	MAGNET COIL 12V	ELECTRO AIMANT 12V	



DECKEL - DECKEL
DECKEL - 470.01.21.00.00/00

470.01.21.00.00/00
Stücklistennummer / Piece Number / Liste de Pièces / Номер



Pos.		Bestell-Nr. Stock Number Numéro de Commande Номер товара	Menge Amount Quantité Количество	Beschreibung	Description	Description	Описание
10		470.01.21.00.01/01	1,000	DECKEL	COVER	COUVERCLE	
20		60.16.015	1,000	DURCHFUEHRUNGSTUELLE D8	DURCHFUEHRUNGSTUELLE D8	DURCHFUEHRUNGSTUELLE D8	
30		01.10.10025	1,000	SKT-SCHRAUBE M10X25 8.8	SCREW M10X25 DIN 933	SCREW M10X25 DIN 933	
40		05.01.10	1,000	SCHEIBE ISO 7090-10-200HV	WASHER B10,5 DIN 125 GALV.	WASHER B10,5 DIN 125 GALV.	
50		05.01.10	1,000	SCHEIBE ISO 7090-10-200HV	WASHER B10,5 DIN 125 GALV.	WASHER B10,5 DIN 125 GALV.	
60		01.10.10025	1,000	SKT-SCHRAUBE M10X25 8.8	SCREW M10X25 DIN 933	SCREW M10X25 DIN 933	

Index / Index / Index / Индекс

Bestell-Nr. Stock Number Numéro de Commande Номер заказа	Pos.	Seite	Bestell-Nr. Stock Number Numéro de Commande Номер заказа	Pos.	Seite	Bestell-Nr. Stock Number Numéro de Commande Номер заказа	Pos.	Seite
01.01.45.16025/A	20	77	01.20.16035.C	70	55	03.02.20	60	215
01.10.10020	40	89	01.20.16040.C	60	113	03.02.20	40	217
01.10.10020	40	93	01.21.16050.C	60	35	03.02.20	40	219
01.10.10020	20	105	01.21.16050.C	70	45	03.03.20.S.C	80	17
01.10.10020	5	197	01.21.16050.C	100	55	03.03.24.T.C	50	35
01.10.10020	170	223	01.21.16050.C	60	65	03.03.24.T.C	60	45
01.10.10025	40	95	01.21.16050.C	50	113	03.03.24.T.C	90	55
01.10.10025	20	111	01.21.16080.C	100	17	03.03.24.T.C	50	65
01.10.10025	50	195	01.30.16040.C.V	80	121	05.01.10	30	89
01.10.10025	4	197	01.30.16040.C.V	90	131	05.01.10	30	93
01.10.10025	20	203	01.30.16040.C.V	100	169	05.01.10	30	95
01.10.10025	20	205	01.40.06016.C.V	6	197	05.01.10	60	105
01.10.10025	20	207	01.60.16100	10	141	05.01.10	30	111
01.10.10025	30	227	01.80.20.S.155.C	90	17	05.01.10	40	195
01.10.10025	60	227	01.80.24.T.085.C	40	35	05.01.10	7	197
01.10.12040	30	145	01.80.24.T.085.C	50	45	05.01.10	30	203
01.10.12040	130	155	01.80.24.T.085.C	80	55	05.01.10	30	205
01.10.12045.C.V	40	105	01.80.24.T.085.C	40	65	05.01.10	30	207
01.10.12045.C.V	190	223	013.01.0.04/00	4	149	05.01.10	210	223
01.10.14050.C	50	105	013.01.0.04/00	5	151	05.01.10	40	227
01.10.14050.C	200	223	013.01.2.06/A	5	149	05.01.10	50	227
01.10.16025	10	83	013.01.2.06/A	4	151	05.01.17	30	75
01.10.16030	20	201	013.03.5.00/02	3	141	05.01.17	50	77
01.10.16035	50	75	013.04.2.00/B	2	149	05.01.17	18	143
01.10.16040	11	141	013.04.2.00/B	2	151	05.01.17	30	201
01.10.16080	30	77	013.04.5.00/02	2	141	05.01.21	30	101
01.10.16080	20	161	03.01.16	14	143	05.01.21	15	193
01.10.20040	14	193	03.02.16	40	75	05.04.17	12	143
01.10.20055	20	101	03.02.16	40	77	05.08.21	50	89
01.10.20055	13	193	03.02.16	40	201	05.08.21	50	93
01.10.20065	70	89	03.02.16	20	211	05.10.060.17.0.J1	90	121
01.10.20065	70	93	03.02.20	60	89	05.10.060.17.0.J1	100	131
01.20.06010	3	149	03.02.20	60	93	05.10.060.17.0.J1	110	169
01.20.06010	9	151	03.02.20	50	213	05.10.080.16.5.J1	120	123

Index / Index / Index / Индекс

Bestell-Nr. Stock Number Numéro de Commande Номер заказа	Pos.	Seite	Bestell-Nr. Stock Number Numéro de Commande Номер заказа	Pos.	Seite	Bestell-Nr. Stock Number Numéro de Commande Номер заказа	Pos.	Seite
05.10.080.16.5.J1	130	133	18.050.062.1	70	121	20.GEV06LL.M10-1/00	16	143
05.10.080.16.5.J1	140	171	18.050.062.1	70	131	20.GEV08L.M12-1.5/00	190	107
07.01.16	60	77	18.050.062.1	90	169	20.GEV08L.M12-1.5/00	120	223
07.02.12	70	105	18.065.085.2	10	183	20.GEV08L.M14-1.5/00	100	77
07.02.12	20	145	18.065.085.2	20	187	20.GEV18L.M18-1.5/00	200	107
07.02.12	150	223	19.02.21.010	80	153	20.GEV18L.M18-1.5/00	130	223
07.02.14	80	105	20.02.00576/00	90	105	20.GEV18L.M22-1.5/00	210	107
07.02.14	160	223	20.02.00576/00	220	223	20.GEV18L.M22-1.5/00	140	223
07.02.16	20	143	20.02.00578/00	100	105	20.SWVE8L-1-4/00	110	77
07.03.12	120	155	20.02.00578/00	230	223	20.UEM08L/00	120	79
08.01.25.16/00	80	81	20.02.14.08.0500.B	80	77	20.UEM18L/00	220	107
08.01.25.16/00	50	215	20.02.14.18.0800.B/00	110	105	20.UEM18L/00	80	221
09.14.09.50	110	121	20.02.14.18.0800.B/00	240	225	20.VS12.1.5/00	230	107
09.14.09.50	120	133	20.29.001/00	120	105	20.VS12.1.5/00	60	221
09.14.09.50	130	171	20.29.001/00	30	221	20.VS14.1.5/00	20	95
09.18.11.40	100	121	20.29.002/00	130	107	20.VS14.1.5/00	240	109
09.18.11.40	110	131	20.29.002/00	50	221	20.VS14.1.5/00	70	221
09.18.11.40	120	171	20.29.005/A	140	107	24.A.06.100	21	143
100275	60	121	20.29.005/A	40	221	24.A.10.100	20	83
100275	60	131	20.41.001/00	150	107	24.A.10.100	8	149
100275	80	169	20.41.001/00	90	221	24.A.10.100	8	151
100302	15	143	20.60.045/A	160	107	24.D.001/00	10	163
11.23.015/00	170	9	20.60.065/00	20	221	24.D.002/00	17	143
12.40.44.30/00	70	77	20.80.030.03	10	147	24.D.002/00	10	165
13.A.0001/00	60	153	20.80.136/00	10	145	24.D.6-45.1/00	19	143
13.A.0002/00	6	149	20.91.005.FE	30	87	25.01.010.04	110	153
13.A.0002/00	3	151	20.92.01.006	20	87	25.01.040.08	130	79
14.0006.02/00	90	153	20.92.025	10	87	28031942/00	250	225
14.03.007/00	6	151	20.BUZ08L/00	90	77	41233326/03	20	97
14.05.ISKD060/00	70	153	20.BUZ18L/00	170	107	41320830/00	100	7
14.05.ISKD080/00	7	149	20.BUZ18L/00	100	221	41375566/00	8	141
14.05.ISKD080/00	7	151	20.EWV18L/00	180	107	41386156/00	2	191
16.01.A050	100	153	20.EWV18L/00	110	221	41402345/02	1	149
16.01.J090	140	155	20.GEV06L.M10-1/00	10	167	41402345/02	1	151

Index / Index / Index / Индекс

Bestell-Nr. Stock Number Numéro de Commande Номер заказа	Pos.	Seite	Bestell-Nr. Stock Number Numéro de Commande Номер заказа	Pos.	Seite	Bestell-Nr. Stock Number Numéro de Commande Номер заказа	Pos.	Seite
42.10.40.04/00	20	195	460.03.00.00.00/A	10	7	470.10.03.00.01/00	10	95
450.02.00.01.01/00	7	141	460.03.00.01.00/A	30	7	470.15.00.00.00/04	180	9
450.02.00.01.02/A	5	141	470.01.00.00.00/02	240	11	470.15.00.01.00/02	250	11
450.02.02.01.00/00	6	141	470.01.01.00.00/C	7	191	470.32.01.00.00/00	150	9
450.02.03.10.00/00	40	121	470.01.01.01.00/00	9	191	470.32.01.00.01/01	10	101
450.02.03.10.00/00	50	131	470.01.01.02.00/00	8	191	48.01.250.3/00	40	131
450.02.03.10.00/00	50	169	470.01.01.05.00/00	10	209	48.01.250.3/00	40	169
450.03.00.00.01/A	10	31	470.01.01.07.00/B	80	209	48.01.280.3/00	10	121
450.06.00.00.00/00	90	7	470.01.01.08.00/01	90	209	48.01.280.3/00	10	131
450.06.20.00.00/B	20	75	470.01.03.00.01/00	12	191	48.01.280.3/00	10	169
450.06.21.00.00/B	10	75	470.01.10.00.00/00	10	201	480.01.04.20.00/01	1	197
450.11.00.00.00/03	140	9	470.01.12.00.00/00	3	191	480.01.04.20.01/01	10	199
451.02.04.02.01/00	50	121	470.01.16.00.00/00	4	191	49.1.3020	10	125
452.03.00.00.01/00	10	13	470.01.16.00.01/00	10	203	49.1.3020	10	127
453.01.03.00.00/00	11	191	470.01.17.00.00/00	5	191	49.1.3020	10	135
46.BCS01/01	6	117	470.01.17.00.01/00	10	205	49.1.3020	10	137
46.BCS02/00	100	113	470.01.18.00.00/00	6	191	49.1.3020	10	177
46.BFZ25.G/00	50	39	470.01.18.00.01/00	10	207	49.1.3020	10	179
46.BFZ25.G/00	50	49	470.01.19.00.00/00	1	191	49.50.3020/00	20	121
46.BFZ25.G/00	50	59	470.01.19.00.01/00	30	195	49.50.3020/00	20	131
46.BFZ25.G/00	50	67	470.01.20.00.00/00	10	105	49.50.3020/00	20	169
46.HDT01.A/B	40	45	470.01.20.00.01/00	10	111	49.65.3020/00	30	121
46.HDT01.A/B	40	55	470.01.21.00.00/00	10	221	49.65.3020/00	30	131
46.HDT02.A/B	20	35	470.01.21.00.01/01	10	227	49.65.3020/00	30	169
46.HDT04.V/A	20	65	470.02.00.00.00/01	220	9	50.1.1740.B.X	10	129
46.HM017/B	50	55	470.02.04.00.00/A	230	11	50.1.1740.B.X	10	139
46.HM028.02.A/B	60	55	470.02.04.01.00/00	200	9	50.1.1740.B.X	10	181
46.UPTS01/03	30	19	470.02.04.02.00/00	210	9	551.01.00.90.00/00	160	9
46.UPTS02/A	40	17	470.03.00.02.00/00	80	7	551.02.05.02.00/A	4	141
46.UPTS04/A	50	17	470.07.00.00.00/A	110	7	551.02.05.02.01/A	20	153
46.UPTS04/A	10	23	470.07.00.01.00/00	120	9	551.02.05.22.00/03	10	153
46.UPTS04/A	10	27	470.07.01.00.00/00	10	89	60.16.015	20	227
46.UPTS05/B	60	17	470.07.01.00.00/00	10	93	62.0.010.01.0320/00	13	143
46.UPTS06/B	70	17	470.10.03.00.00/00	130	9	729.01.16.00.01/A	3	197

Index / Index / Index / Индекс

Bestell-Nr. Stock Number Numéro de Commande Номер заказа	Pos.	Seite	Bestell-Nr. Stock Number Numéro de Commande Номер заказа	Pos.	Seite	Bestell-Nr. Stock Number Numéro de Commande Номер заказа	Pos.	Seite
740.01.19.00.01/00	10	195	754.03.00.00.01/I	1	63			
740.02.03.00.02/A	30	153	754.03.00.00.01/I	30	65			
740.02.12.00.00/00	1	141	754.03.00.00.01/I	1	71			
740.03.00.00.00/B	40	7	754.03.00.00.01/I	30	113			
740.03.00.00.01/01	20	17	754.03.00.00.01/I	1	119			
740.03.00.00.01/01	70	35	754.20.5.02/A	60	169			
740.03.00.00.01/01	30	45	777.02.01.00.02/A	10	73			
740.03.00.00.01/01	30	55	796.6.2.65/B	70	169			
740.03.00.00.01/01	70	65	796.6.2.66/B	80	131			
740.03.00.00.01/01	20	113	799.1.02.42	9	141			
740.03.00.01.00/C	50	7	84.110.03.12/00	20	103			
740.03.00.02.00/A	60	7	85.003.001/04	10	103			
740.03.00.04.00/00	70	7	85.01.109/00	10	97			
740.03.01.00.00/E	10	35	85.01.13/00	4	99			
740.03.01.00.00/E	10	45	85.01.132/02	20	31			
740.03.01.00.00/E	10	55	85.01.133/02	20	13			
740.03.01.00.00/E	10	65	85.01.138/01	1	99			
740.03.01.00.01/F	20	39	85.01.148/01	2	99			
740.03.01.00.01/F	20	49	85.01.17/00	6	99			
740.03.01.00.01/F	20	59	85.01.20/00	9	99			
740.03.01.00.01/F	20	67	85.01.21/00	3	99			
740.07.00.00.01/00	20	89	85.01.22/00	7	99			
740.07.00.00.01/00	20	93	85.01.27/00	8	99			
740.10.00.00.01/A	140	79	85.01.28/00	5	99			
740.10.01.00.00/D	10	77	85.01.33/A	30	97			
742.10.00.00.01/00	150	79	857.03.00.67.00/B	190	9			
742.10.03.00.00/00	160	79	857.03.00.68.00/00	20	7			
754.03.00.00.01/I	30	17	857.03.01.67.00/03	10	113			
754.03.00.00.01/I	1	21	857.03.01.68.00/00	10	17			
754.03.00.00.01/I	30	35	857.03.03.28.01/00	40	19			
754.03.00.00.01/I	1	43	857.03.03.28.02/00	5	117			
754.03.00.00.01/I	20	45	991.05.04.00.01/00	40	153			
754.03.00.00.01/I	1	53	991.05.04.00.02/00	50	153			
754.03.00.00.01/I	20	55	991.10.12.00.00/00	170	79			