

Prinoth[®]

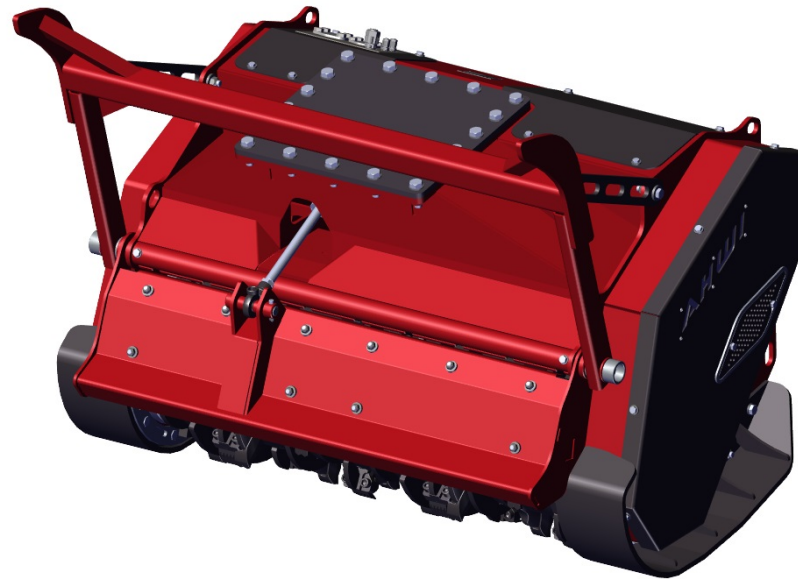

Ersatzteilliste / Spare Parts List / Catalogue pièces / каталог запасных частей

Mulchfräse

Serial-Nr.: M550E-1300-VERS02

PRINOTH GmbH - Im Branden 15 - D-88634 Herdwangen
Fon +49 (0) 7557 9212-0
prinoth.germany@prinoth.com - www.prinoth.com

Aufbau der Ersatzteillisten / Layout of parts lists / Conception des listes de pièces détachées / Структура списков запасных частей:

Die Ersatzteilliste ist in Hauptbaugruppen und Unterbaugruppen aufgeteilt. Zu den Positions-Nummern auf den Bildtafeln finden Sie in der Stückliste das betreffende Prinoth Ersatzteil.

Achten Sie auf die Mengenangabe jeder übergeordneten Baugruppe um die Gesamtmenge pro Maschine zu ermitteln.

Die Bestellmenge, die in der übergeordneten Baugruppe angegeben ist, multipliziert sich also mit der Mengenangabe der untergeordneten Bauteile.

Spare parts lists are divided into primary assemblies and secondary assemblies. Prinoth spare parts are listed in bills of material numbered according to the item numbers you can see in the illustrations.

Take care when specifying the quantity for each higher-level (primary) assembly, as this number is used to calculate the total number of items for each machine. The order quantity specified for the higher-level (primary) assembly is multiplied by the number of lower-level (secondary) components specified.

La liste des pièces détachées est divisée en unités principales et en unités secondaires. Les numéros de position des tableaux illustrés vous indiquent dans la liste de pièces la pièce détachée Prinoth correspondante.

Tenez compte de l'indication de quantité de chaque unité supérieure afin de déterminer la quantité globale par machine.

La quantité à commander, indiquée dans l'unité supérieure, se multiplie donc par l'indication de quantité des composants inférieurs.

Списки запасных частей подразделяются на основные и подчиненные узлы. В спецификации по номерам позиции, указанным на выносках чертежа, вы найдете

соответствующую запасную часть фирмы Prinoth.

Для определения общего количества на каждую машину воспользуйтесь количеством, указанным в каждом подчиненном узле.

Таким образом, заказываемое количество, указанное в узле более высокого уровня, необходимо умножить на указанное количество подчиненных деталей.

BEISPIEL: „Riemenübersetzung“ mit Untergruppenbauteil „Keilriemenscheibe“ / EXAMPLE: “Belt transmission” with “V-belt pulley” as a secondary component /
EXEMPLE : « transmission par courroie » avec unité secondaire « poulie à gorge pour courroie trapézoïdale » / ПРИМЕР: «Ременная передача» с деталью «Клиноременный шкив» подчиненного узла

Mulchfräse M550-2110 - Mulcher M550-2110 broyeur forestier M550-2110 - Лесные фрезы M550-2110		551.00.00.00/A Stücklistennummer / Piece Number / Liste de Pièces / Номер		Prinoth	
Pos.	Bausatz-Nr. Stock Number Numéro de Commande Номер товара	Menge Amount Quantité шт.	Beschreibung	Description	Описание
12	650.02.06.03.00	2	Seitengelenkwelle	Side shaft w. friction clutch	cardan latéral карданный вал
13	650.02.04.00.00/D	2	Riemenübersetzung	Belt transmission i 1,13	transmission переход ремня
14	650.02.04.01.00/D	2	Riemenübersetzung	Belt transmission i 1,0	transmission переход ремня

Riemenübersetzung - Belt transmission i 1,0 transmission - переход ремня		650.02.04.01.00/D Stücklistennummer / Piece Number / Liste de Pièces / Номер		Prinoth	
Pos.	Bausatz-Nr. Stock Number Numéro de Commande Номер товара	Menge Amount Quantité шт.	Beschreibung	Description	Описание
1	48.01.300.4	2	Keilriemenscheibe	V-Belt Pulley 300x4	poulie à gorge pour courroie trapézoïdale Шкив клиноременной передачи
2	49.65.3020	1	Taperlock	Taperlock-Bushing Ø 65 /3020	moyeu de serrage Запорная коническая втулка
3	49.60.3020	1	Taperlock	Taperlock-Bushing Ø 50 /3020	moyeu de serrage Запорная коническая втулка

2x Riemenübersetzung = 2x2 Keilriemenscheiben → Bestellwert 4 Stück!!

2x belt transmission = 2x2 V-belt pulley → Order value 4 items!!

2x transmission par courroie = 2x2 poulies à gorge pour courroie trapézoïdale → Quantité à commander 4 pièces !!

2x ременных передачи = 2x2 клиноременных шкива → Заказываемое значение 4 штуки!!

1	M550E-1300 / M550E-1300 / M550E-1300.....	6
1.1	GEHAEUSE GESCHRAUBT M550E / GEHAEUSE GESCHRAUBT M550E / GEHAEUSE GESCHRAUBT M550E.....	12
1.1.1	KETTENVORHANG M550E - 1300MM / KETTENVORHANG M550E - 1300MM / KETTENVORHANG M550E - 1300MM.....	16
1.1.1.1	KETTENVORHANG GESCHWEISST - 1300MM / KETTENVORHANG GESCHWEISST - 1300MM / KETTENVORHANG GESCHWEISST - 1300MM.....	18
1.1.2	DECKEL-GESCHRAUBT M550 / COVER-SCREWED M550 / COUVERCLE-VISSE M550.....	20
1.1.2.1	LOGO-GESCHWEISST / LOGO-WELDED / LOGO-SOUDE.....	22
1.1.2.2	SICHERUNGSSCHRAUBE / SICHERUNGSSCHRAUBE / SICHERUNGSSCHRAUBE.....	24
1.1.3	WARTUNGSDECKEL GESCHRAUBT / WARTUNGSDECKEL GESCHRAUBT / WARTUNGSDECKEL GESCHRAUBT.....	26
1.1.4	WARTUNGSDECKEL GESCHRAUBT / WARTUNGSDECKEL GESCHRAUBT / WARTUNGSDECKEL GESCHRAUBT.....	28
1.1.5	WARTUNGSDECKEL GESCHRAUBT / WARTUNGSDECKEL GESCHRAUBT / WARTUNGSDECKEL GESCHRAUBT.....	30
1.1.6	WARTUNGSDECKEL GESCHRAUBT / WARTUNGSDECKEL GESCHRAUBT / WARTUNGSDECKEL GESCHRAUBT.....	32
1.1.7	WARTUNGSDECKEL GESCHRAUBT / WARTUNGSDECKEL GESCHRAUBT / WARTUNGSDECKEL GESCHRAUBT.....	34
1.1.8	ROTORSCHLITZABDECKUNG SYMMETRISCH / ROTORSCHLITZABDECKUNG SYMMETRISCH / ROTORSCHLITZABDECKUNG SYMMETRISCH.....	36
1.1.9	DOKUMENTENHALTER GESCHRAUBT / DOKUMENTENHALTER GESCHRAUBT / DOKUMENTENHALTER GESCHRAUBT.....	38
1.1.10	TYPENSCHILD + NIETEN / TYPENSCHILD + NIETEN / TYPENSCHILD + NIETEN.....	40
1.1.11	GEHAEUSE M550E - GESCHWEISST / GEHAEUSE M550E - GESCHWEISST / GEHAEUSE M550E - GESCHWEISST.....	42
1.1.11.1	KONSOLE GESCHWEISST / KONSOLE GESCHWEISST / KONSOLE GESCHWEISST.....	44
1.2	ANTRIEB EINSEITIG - OHNE HYDR.-MOTOR / DRIVE W/O HYD. MOTOR - 1 SIDE / DRIVE W/O HYD. MOTOR - 1 SIDE.....	46
1.2.1	FESTLAGER D65X140 SCHRAUBB. STU. IR 31 / FIXED BEARING D65/140 FM600PR. / FIXED BEARING D65/140 FM600PR.....	48
1.2.2	LOSLAGER D65X140 - DISTANZRING 31 / LOSLAGER D65X140 - DISTANZRING 31 / LOSLAGER D65X140 - DISTANZRING 31.....	52
1.2.3	SPANNROLLE-AUSSEN / TENSIONING PULLEY-OUTSIDE / POULIE DE TENSION-EXTERIEUR.....	56
1.2.3.1	SPANNROLLE / TENSIONING PULLEY / POULIE DE TENSION.....	60
1.3	HYDR.-MOTOR 80CCM / HYDR.-MOTOR 80CCM / HYDR.-MOTOR 80CCM.....	62
1.3.1	LAGERGLOCKE 4-LOCH, LK 180, DIN 5480 / BEARING UNIT / BEARING UNIT.....	66
1.3.2	AXKO-VERSTELLMOTOR 80CCM / AXIAL PISTON MOTOR 80CC / AXIAL PISTON MOTOR 80CC.....	74
1.4	HYDR.-MOTOR 160CCM / HYDR.-MOTOR 160CCM / HYDR.-MOTOR 160CCM.....	76
1.4.1	LAGERGLOCKE / BEARING HOUSING / BEARING HOUSING.....	84
1.4.2	AXKO-VERSTELLMOTOR 160CCM / AXIAL PISTON MOTOR 160CCM / AXIAL PISTON MOTOR 160CCM.....	88
1.5	RIEMENUEBERSETZUNG I 1,13 / BELT RATIO I=1,13 - 80CCM / BELT RATIO I=1,13 - 80CCM.....	90
1.5.1	TAPERLOCK 3525 D65 / TAPERLOCK-BUSHING D 65 /3525 / TAPERLOCK-BUSHING D 65 /3525.....	94
1.5.2	TAPERLOCK 3020 D50 / TAPERLOCK-BUSHING D 50 /3020 / TAPERLOCK-BUSHING D 50 /3020.....	96
1.5.3	DISTANZRING D75X4,5X18 / DISTANCE RING / DISTANCE RING.....	98
1.5.4	DISTANZRING D75X4,5X4 / DISTANCE RING / DISTANCE RING.....	100
1.6	RIEMENUEBERSETZUNG I 1,13 / BELT RATIO I=1,13 - 160CCM / BELT RATIO I=1,13 - 160CCM.....	104
1.6.1	TAPERLOCK 3525 D65 / TAPERLOCK-BUSHING D 65 /3525 / TAPERLOCK-BUSHING D 65 /3525.....	108

1.6.2	TAPERLOCK 3020 D65 / TAPERLOCK-BUSHING D 65 /3020 / TAPERLOCK-BUSHING D 65 /3020.....	110
1.6.3	DISTANZRING D75X4,5X18 / DISTANCE RING / DISTANCE RING.....	112
1.6.4	DISTANZRING D75X4,5X4 / DISTANCE RING / DISTANCE RING.....	114
1.6.5	DISTANZRING D75X4,5X12 / DISTANCE RING / DISTANCE RING.....	118
1.7	LECKOELVERSCHRAUBUNG DIN FUER 80CCM / LEAK-OIL FITTING - 80CCM DIN / LEAK-OIL FITTING - 80CCM DIN.....	120
1.8	LECKOELVERSCHRAUBUNG DIN FUER 160CCM / LEAK-OIL FITTING - 160CCM DIN / LEAK-OIL FITTING - 160CCM DIN.....	124
1.9	LECKOELVERSCHRAUBUNG JIC FUER 80CCM / LEAK-OIL FITTING - 80CCM JIC / LEAK-OIL FITTING - 80CCM JIC.....	128
1.9.1	EINSCHRAUBSTUTZEN JIC37 / MALE STUD / MALE STUD.....	132
1.10	LECKOELVERSCHRAUBUNG JIC FUER 160CCM / LEAK-OIL FITTING - 160CCM JIC / LEAK-OIL FITTING - 160CCM JIC.....	134
1.11	ANSCHLUSSBLOCK MIT RUECKSCHLAGVENTIL / ANSCHLUSSBLOCK MIT RUECKSCHLAGVENTIL / ANSCHLUSSBLOCK MIT RUECKSCHLAGVENTIL....	138
1.12	STANDARDKUFEN SATZ M550 / STANDARD SKIDS / STANDARD SKIDS.....	146
1.13	HOCHKUFEN SATZ M550 / HIGH SKIDS / HIGH SKIDS.....	150
1.14	DECKEL WENN OHNE Klappe / DECKEL WENN OHNE Klappe / DECKEL WENN OHNE Klappe.....	152
1.15	Klappe MIT GEGENSCHNEIDE M550E / FLAP W. COUNTER BLADES / FLAP W. COUNTER BLADES.....	154
1.15.1	Klappe GESCHWEISST / Klappe GESCHWEISST / Klappe GESCHWEISST.....	156
1.15.2	GEGENSCHNEIDE GESCHWEISST - FUER Klappe / GEGENSCHNEIDE GESCHWEISST - FUER Klappe / GEGENSCHNEIDE GESCHWEISST - FUER Klappe	158
1.15.3	BOLZEN MIT SCHRAUBE / BOLZEN MIT SCHRAUBE / BOLZEN MIT SCHRAUBE.....	160
1.15.4	BOLZEN MIT SCHRAUBE / BOLZEN MIT SCHRAUBE / BOLZEN MIT SCHRAUBE.....	164
1.16	Klappe OHNE GEGENSCHNEIDE M550E / FLAP W/O COUNTER BLADES / FLAP W/O COUNTER BLADES.....	168
1.16.1	Klappe GESCHWEISST / Klappe GESCHWEISST / Klappe GESCHWEISST.....	170
1.16.2	BOLZEN MIT SCHRAUBE / BOLZEN MIT SCHRAUBE / BOLZEN MIT SCHRAUBE.....	172
1.16.3	BOLZEN MIT SCHRAUBE / BOLZEN MIT SCHRAUBE / BOLZEN MIT SCHRAUBE.....	176
1.17	HYDRAULIK FUER Klappe JIC / HYDRAULICS JIC / HYDRAULICS JIC.....	180
1.18	HYDRAULIK FUER Klappe DIN / HYDRAULICS DIN / HYDRAULICS DIN.....	184
1.19	DRUECKEVORRICHTUNG STARR GESCHRAUBT / FIXED PUSH-BAR / FIXED PUSH-BAR.....	188
1.19.1	BOLZEN FUER Klappe / BOLZEN FUER Klappe / BOLZEN FUER Klappe.....	190
1.20	DISTANZEN / DISTANCE BUSHINGS / DISTANCE BUSHINGS.....	194
1.20.1	BOLZEN FUER Klappe KLEIN / BOLZEN FUER Klappe KLEIN / BOLZEN FUER Klappe KLEIN.....	196
1.21	ROTOR D550 1300 24XBCS / ROTOR D550 1300 24XBCS / ROTOR D550 1300 24XBCS.....	200
1.21.1	ROTOR-GESCHWEISST / ROTOR-WELDED / ROTOR-SOUDE.....	202
1.21.2	ROTORSTUMMEL KURZ / ROTOR SHOFT / ROTOR SHOFT.....	204
1.22	LABYRINTHDICHTUNG M550 / LABYRINTHDICHTUNG M550 / LABYRINTHDICHTUNG M550.....	206
1.23	ROTOR D550 1300 32XUPTS / ROTOR D550 1300 32XUPTS / ROTOR D550 1300 32XUPTS.....	208
1.23.1	ROTOR-GESCHWEISST / ROTOR-WELDED / ROTOR-SOUDE.....	210
1.23.2	ROTORSTUMMEL KURZ / ROTOR SHOFT / ROTOR SHOFT.....	212

1.23.3 WERKZEUG UPTS05 / TOOL UPTS05 / OUTIL UPTS05	214
1.23.4 WERKZEUG UPTS06 / TOOL UPTS06 / OUTIL UPTS06	218
1.24 LABYRINTHDICHTUNG-UPTS / LABYRINTH SEALING-UPTS / LABYRINTH SEALING-UPTS	222
1.25 SCHMIERUNG MANUELL / LUBRICATION / LUBRICATION	226
1.25.1 GER-EINSCHR-VERSCHR. 6L M10X1 / STRAIGHT SCREW FITTING 6L M10 / STRAIGHT SCREW FITTING 6L M10	230
1.26 PRODUKTGRAFIK / PRODUCT GRAPHICS / GRAPHIQUE DU PRODUIT	232
1.26.1 PRODUKTGRAFIK-MULCHGERAET / PRODUCT GRAPHICS-MULCHER / GRAPHIQUE DU PRODUIT-BROYEUR.....	234
1.27 ANBAUPLATTE UNIVERSAL GESCHRAUBT / UNIVERSAL INTERFACE / UNIVERSAL INTERFACE	236
1.28 ANBAUPLATTE-TILT MOTOR / ATTACHMENT PLATE-TILT MOTOR / PLAQUE DE MONTAGE-TILT MOTEUR.....	240
1.28.1 ANBAUPLATTE-TILT MOTOR / ATTACHMENT PLATE-TILT MOTOR / PLAQUE DE MONTAGE-TILT MOTEUR.....	242
Index / Index / Index / Индекс.....	244

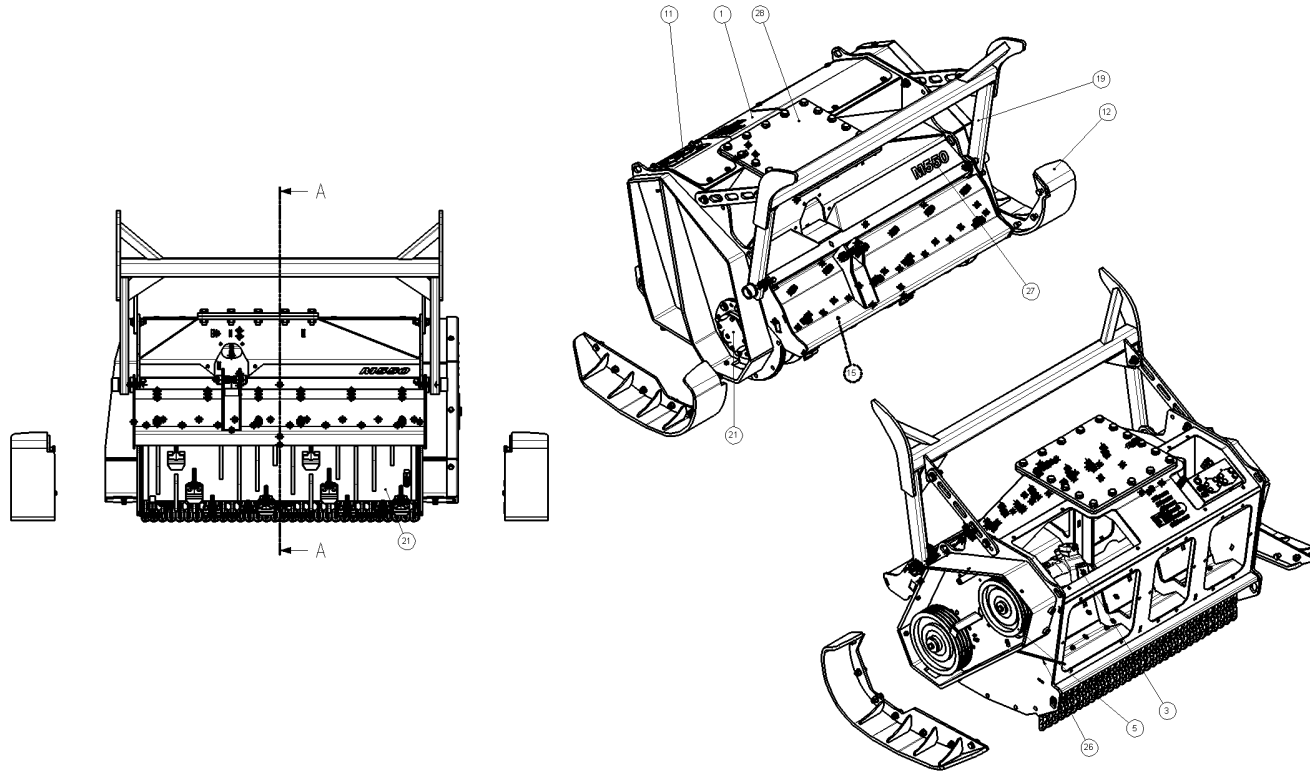

M550E-1300 - M550E-1300
M550E-1300 - 560.00.00.00.00/02

560.00.00.00.00/02
Stücklistennummer / Piece Number / Liste de Pièces / Homep





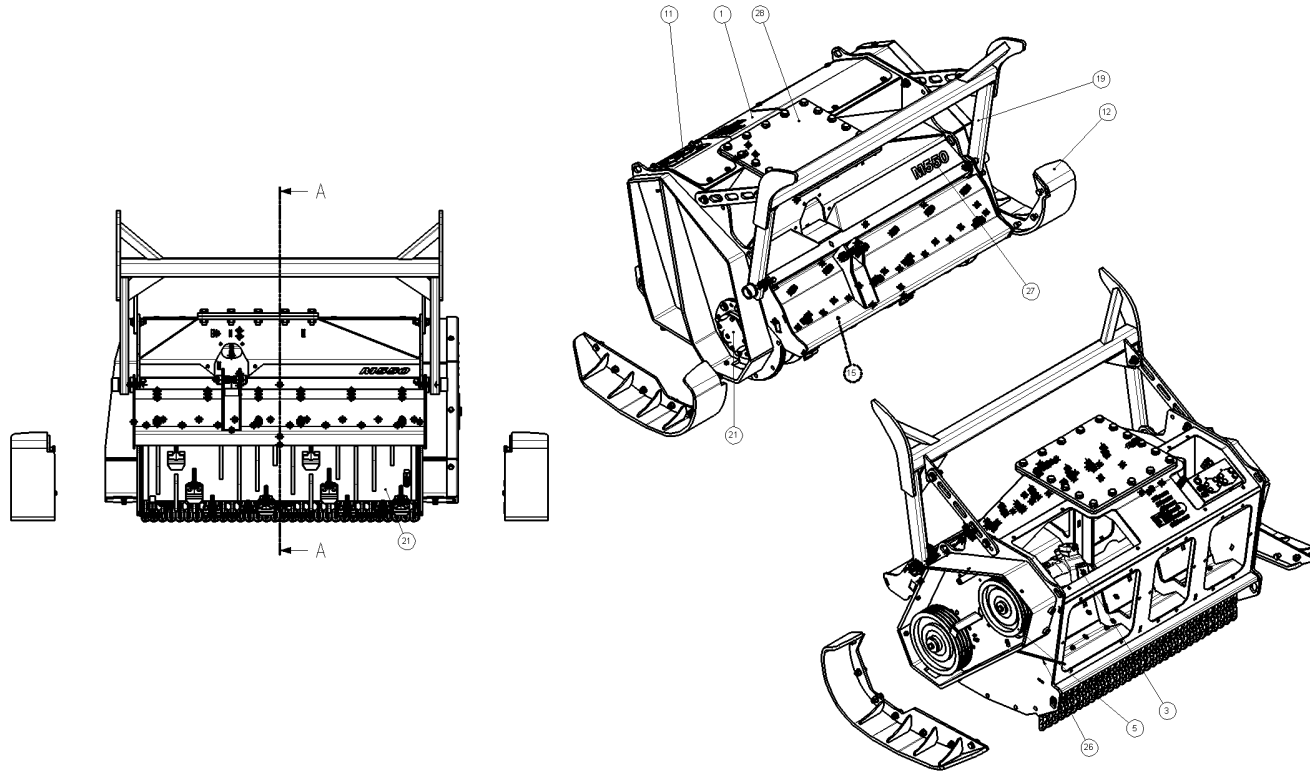







Pos.		Bestell-Nr. Stock Number Numéro de Commande Номер товара	Menge Amount Quantité Количество	Beschreibung	Description	Description	Описание
1		560.01.00.00.00/01	1,000	<u>GEHAEUSE GESCHRAUBT M550E</u>	GEHAEUSE GESCHRAUBT M550E	GEHAEUSE GESCHRAUBT M550E	
2		560.02.00.00.00/01	1,000	<u>ANTRIEB EINSEITIG - OHNE HYDR.-MOTOR</u>	DRIVE W/O HYD. MOTOR - 1 SIDE	DRIVE W/O HYD. MOTOR - 1 SIDE	
3		560.02.00.01.00/A	1,000	<u>HYDR.-MOTOR 80CCM</u>	HYDR.-MOTOR 80CCM	HYDR.-MOTOR 80CCM	
4		560.02.00.02.00/A	1,000	<u>HYDR.-MOTOR 160CCM</u>	HYDR.-MOTOR 160CCM	HYDR.-MOTOR 160CCM	
5		560.02.04.03.00/00	1,000	<u>RIEMENUEBERSETZUNG I 1,13</u>	BELT RATIO I=1,13 - 80CCM	BELT RATIO I=1,13 - 80CCM	
6		560.02.04.02.00/00	1,000	<u>RIEMENUEBERSETZUNG I 1,13</u>	BELT RATIO I=1,13 - 160CCM	BELT RATIO I=1,13 - 160CCM	
7		560.15.00.02.00/A	1,000	<u>LECKOELVERSCHRAUBUNG DIN FUER 80CCM</u>	LEAK-OIL FITTING - 80CCM DIN	LEAK-OIL FITTING - 80CCM DIN	
8		560.15.00.04.00/A	1,000	<u>LECKOELVERSCHRAUBUNG DIN FUER 160CCM</u>	LEAK-OIL FITTING - 160CCM DIN	LEAK-OIL FITTING - 160CCM DIN	
9		560.15.00.03.00/A	1,000	<u>LECKOELVERSCHRAUBUNG JIC FUER 80CCM</u>	LEAK-OIL FITTING - 80CCM JIC	LEAK-OIL FITTING - 80CCM JIC	
10		560.15.00.05.00/A	1,000	<u>LECKOELVERSCHRAUBUNG JIC FUER 160CCM</u>	LEAK-OIL FITTING - 160CCM JIC	LEAK-OIL FITTING - 160CCM JIC	
11		560.15.00.06.00/B	1,000	<u>ANSCHLUSSBLOCK MIT RUECKSCHLAGVENTIL</u>	ANSCHLUSSBLOCK MIT RUECKSCHLAGVENTIL	ANSCHLUSSBLOCK MIT RUECKSCHLAGVENTIL	



M550E-1300 - M550E-1300
M550E-1300 - 560.00.00.00.00/02

560.00.00.00.00/02
Stücklistennummer / Piece Number / Liste de Pièces / Номер





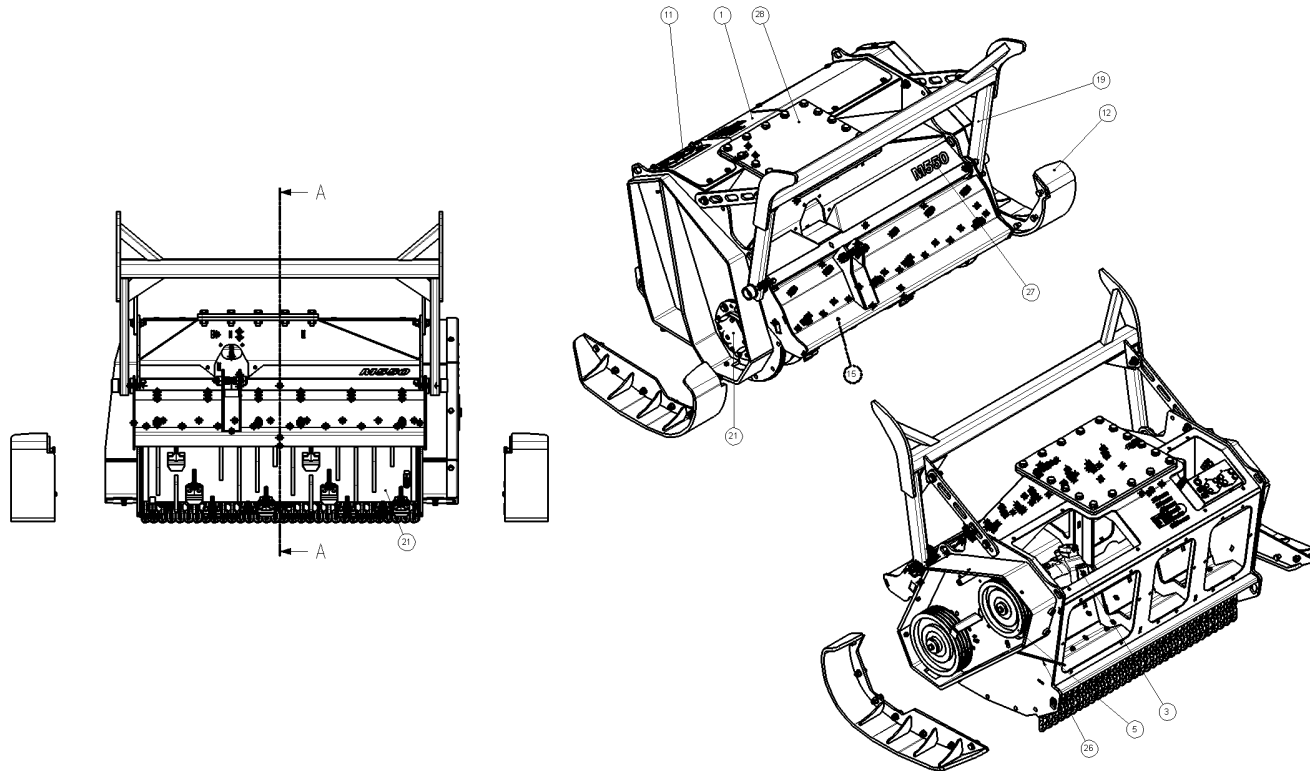



Pos.	Bestell-Nr. Stock Number Numéro de Commande Номер товара	Menge Amount Quantité Количество	Beschreibung	Description	Description	Описание
12	 550.06.00.00.00/B	1,000	<u>STANDARDKUFEN SATZ M550</u>	STANDARD SKIDS	STANDARD SKIDS	
13	 550.06.00.01.00/00	1,000	<u>HOCHKUFEN SATZ M550</u>	HIGH SKIDS	HIGH SKIDS	
14	 560.10.03.00.00/00	1,000	<u>DECKEL WENN OHNE Klappe</u>	DECKEL WENN OHNE Klappe	DECKEL WENN OHNE Klappe	
15	 560.10.00.01.00/00	1,000	<u>Klappe mit Gegenschneide M550E</u>	FLAP W. COUNTER BLADES	FLAP W. COUNTER BLADES	
16	 560.10.00.00.00/00	1,000	<u>Klappe ohne Gegenschneide M550E</u>	FLAP W/O COUNTER BLADES	FLAP W/O COUNTER BLADES	
17	 560.15.00.01.00/A	1,000	<u>HYDRAULIK fuer Klappe JIC</u>	HYDRAULICS JIC	HYDRAULICS JIC	
18	 560.15.00.00.00/A	1,000	<u>HYDRAULIK fuer Klappe DIN</u>	HYDRAULICS DIN	HYDRAULICS DIN	
19	 560.07.00.01.00/00	1,000	<u>Drueckevorrichtung Starr geschraubt</u>	FIXED PUSH-BAR	FIXED PUSH-BAR	
20	 560.07.00.00.00/00	1,000	<u>Distanzen</u>	DISTANCE BUSHINGS	DISTANCE BUSHINGS	
21	 857.03.00.64.00/01	1,000	<u>ROTOR D550 1300 24XBCS</u>	ROTOR D550 1300 24XBCS	ROTOR D550 1300 24XBCS	
22	 551.03.00.02.00/00	1,000	<u>LABYRINTHDichtung M550</u>	LABYRINTHDichtung M550	LABYRINTHDichtung M550	



M550E-1300 - M550E-1300
M550E-1300 - 560.00.00.00.00/02

560.00.00.00.00/02
Stücklistennummer / Piece Number / Liste de Pièces / Номер



Pos.	Bestell-Nr. Stock Number Numéro de Commande Номер товара	Menge Amount Quantité Количество	Beschreibung	Description	Description	Описание
23	 857.03.00.63.00/00	1,000	<u>ROTOR D550 1300 32XUPTS</u>	ROTOR D550 1300 32XUPTS	ROTOR D550 1300 32XUPTS	
24	41248141/00	1,000	<u>LABYRINTHDICHTUNG-UPTS</u>	LABYRINTH SEALING-UPTS	LABYRINTH SEALING-UPTS	
25	 560.14.00.00.00/00	1,000	GESTELL FUER M550E	GESTELL FUER M550E	GESTELL FUER M550E	
26	 560.20.00.00.00/A	1,000	<u>SCHMIERUNG MANUELL</u>	LUBRICATION	LUBRICATION	
27	 560.11.00.00.00/02	1,000	<u>PRODUKTGRAFIK</u>	PRODUCT GRAPHICS	GRAPHIQUE DU PRODUIT	
28	 560.32.00.00.00/A	1,000	<u>ANBAUPLATTE UNIVERSAL GESCHRAUBT</u>	UNIVERSAL INTERFACE	UNIVERSAL INTERFACE	
29	41384104/00	2,000	<u>ANBAUPLATTE-TILT MOTOR</u>	ATTACHMENT PLATE-TILT MOTOR	PLAQUE DE MONTAGE-TILT MOTEUR	
30	 11.23.015/00	1,000	ENTLUEFTUNGSKIT HYDRAULIK	BREATHER KIT HYDRAULIC CIRCUIT	BREATHER KIT HYDRAULIC CIRCUIT	
31	 20.RV1.1-4.0.2/00	1,000	RUECKSCHLAGVENTIL 1 1/4 0,2BAR	NON-RETURN VALVE 1 1/4	NON-RETURN VALVE 1 1/4	

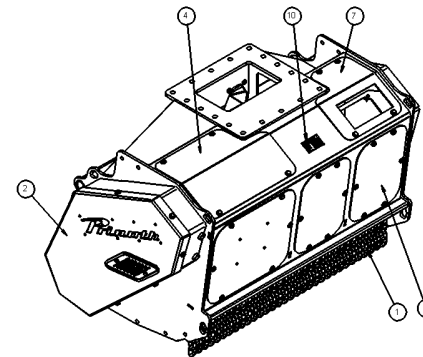
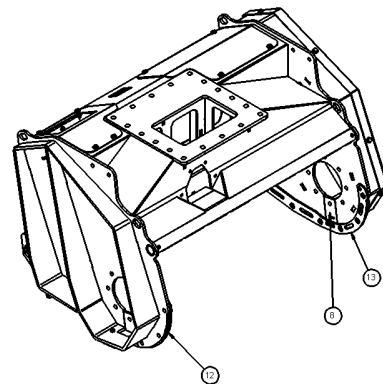

GEHAEUSE GESCHRAUBT M550E - GEHAEUSE GESCHRAUBT M550E
 GEHAEUSE GESCHRAUBT M550E - 560.01.00.00/01

560.01.00.00/01
 Stücklistennummer / Piece Number / Liste de Pièces / Homep



Pos.		Bestell-Nr. Stock Number Numéro de Commande Номер товара	Menge Amount Quantité Количество	Beschreibung	Description	Description	Описание
1		560.01.19.00.00/00	1,000	<u>KETTENVORHANG M550E - 1300MM</u>	KETTENVORHANG M550E - 1300MM	KETTENVORHANG M550E - 1300MM	
2		41387729/00	1,000	<u>DECKEL-GESCHRAUBT M550</u>	COVER-SCREWED M550	COUVERCLE-VISSE M550	
3		560.01.12.00.00/00	1,000	<u>WARTUNGSDECKEL GESCHRAUBT</u>	WARTUNGSDECKEL GESCHRAUBT	WARTUNGSDECKEL GESCHRAUBT	
4		560.01.12.03.00/00	1,000	<u>WARTUNGSDECKEL GESCHRAUBT</u>	WARTUNGSDECKEL GESCHRAUBT	WARTUNGSDECKEL GESCHRAUBT	
5		560.01.12.01.00/00	1,000	<u>WARTUNGSDECKEL GESCHRAUBT</u>	WARTUNGSDECKEL GESCHRAUBT	WARTUNGSDECKEL GESCHRAUBT	
6		560.01.12.02.00/00	1,000	<u>WARTUNGSDECKEL GESCHRAUBT</u>	WARTUNGSDECKEL GESCHRAUBT	WARTUNGSDECKEL GESCHRAUBT	
7		560.01.12.04.00/00	1,000	<u>WARTUNGSDECKEL GESCHRAUBT</u>	WARTUNGSDECKEL GESCHRAUBT	WARTUNGSDECKEL GESCHRAUBT	
8		551.01.17.01.00/00	2,000	<u>ROTORSCHLITZABDECKUNG SYMMETRISCH</u>	ROTORSCHLITZABDECKUNG SYMMETRISCH	ROTORSCHLITZABDECKUNG SYMMETRISCH	
9		650.01.22.00.00/00	1,000	<u>DOKUMENTENHALTER GESCHRAUBT</u>	DOKUMENTENHALTER GESCHRAUBT	DOKUMENTENHALTER GESCHRAUBT	
10		551.01.00.90.00/00	1,000	<u>TYPENSCHILD + NIETEN</u>	TYPENSCHILD + NIETEN	TYPENSCHILD + NIETEN	
11		560.01.01.00.00/D	1,000	<u>GEHAEUSE M550E - GESCHWEISST</u>	GEHAEUSE M550E - GESCHWEISST	GEHAEUSE M550E - GESCHWEISST	

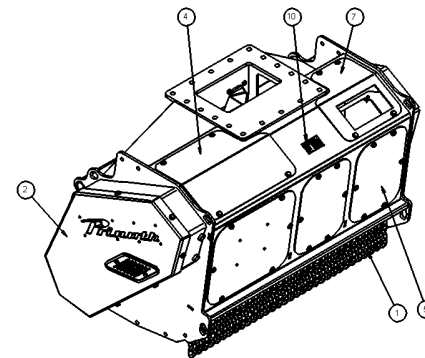
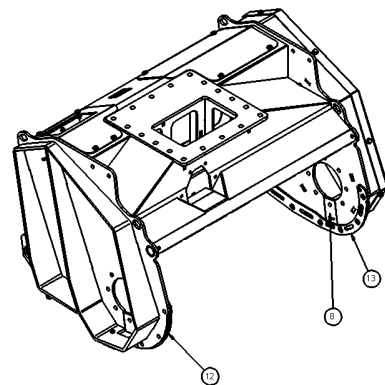



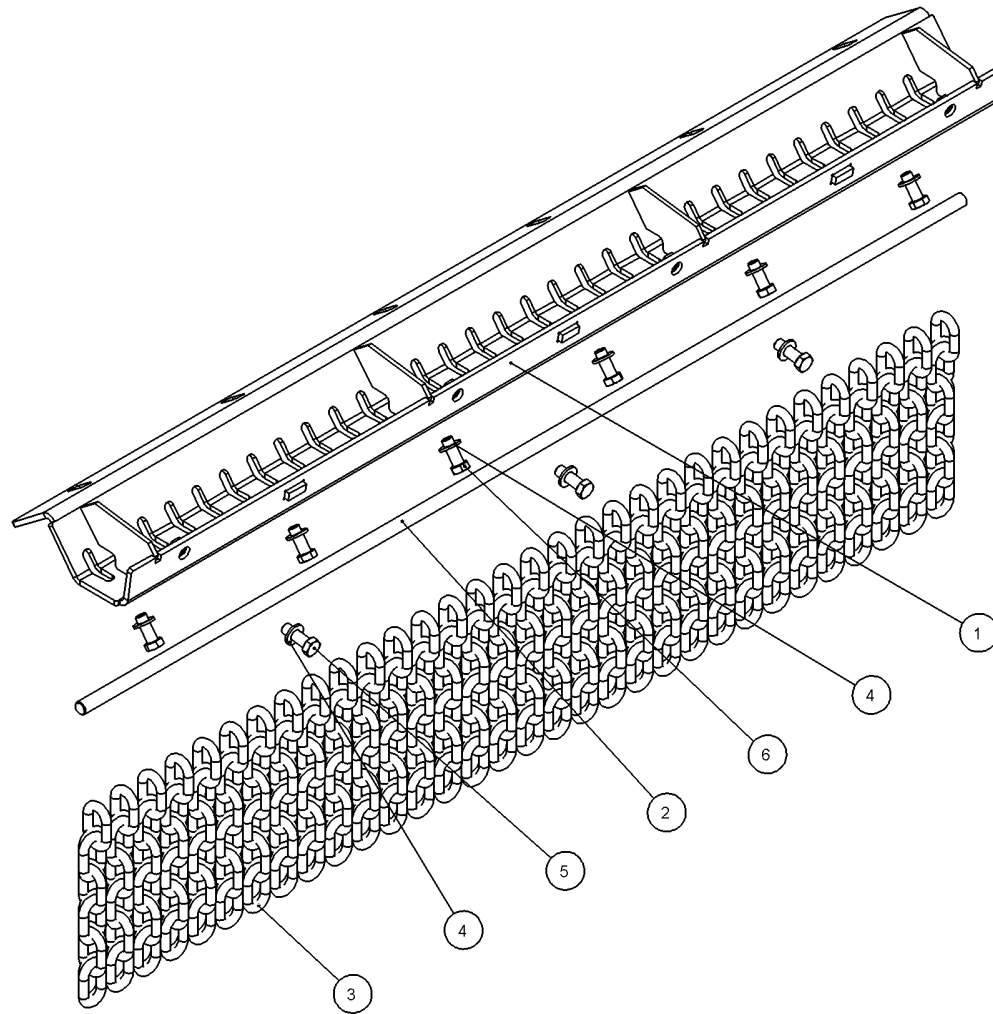



Pos.	Bestell-Nr. Stock Number Numéro de Commande Номер товара	Menge Amount Quantité Количество	Beschreibung	Description	Description	Описание
12	 550.01.02.01.00/00	1,000	VERSCHLEISSLEISTE RECHTS	VERSCHLEISSLEISTE RECHTS	VERSCHLEISSLEISTE RECHTS	
13	 550.01.03.01.00/00	1,000	VERSCHLEISSLEISTE LINKS	VERSCHLEISSLEISTE LINKS	VERSCHLEISSLEISTE LINKS	



KETTENVORHANG M550E - 1300MM - KETTENVORHANG M550E - 1300MM
 KETTENVORHANG M550E - 1300MM - 560.01.19.00.00/00

560.01.19.00.00/00
 Stücklistennummer / Piece Number / Liste de Pièces / Номер



Pos.		Bestell-Nr. Stock Number Numéro de Commande Номер товара	Menge Amount Quantité Количество	Beschreibung	Description	Description	Описание
10		560.01.19.20.00/00	1,000	KETTENVORHANG GESCHWEISST - 1300MM	KETTENVORHANG GESCHWEISST - 1300MM	KETTENVORHANG GESCHWEISST - 1300MM	
20		560.01.19.00.01/00	1,000	STANGE KETTENVORHANG	STANGE KETTENVORHANG	STANGE KETTENVORHANG	
30		42.10.40.11	32,0- 00	GLIEDERKETTE	LINK CHAIN	CHAINE A MAILLONS	
40		05.01.13	10,0- 00	SCHEIBE ISO 7090-13-200HV	WASHER B13 DIN 125 GALVANIZED	WASHER B13 DIN 125 GALVANIZED	
50		01.10.12035	4,000	SKT-SCHRAUBE M12X35 8.8	SCREW M12X35 DIN 933	SCREW M12X35 DIN 933	
60		01.10.12030	6,000	SKT-SCHRAUBE M12X30 8.8	SCREW M12X30 DIN 933	SCREW M12X30 DIN 933	

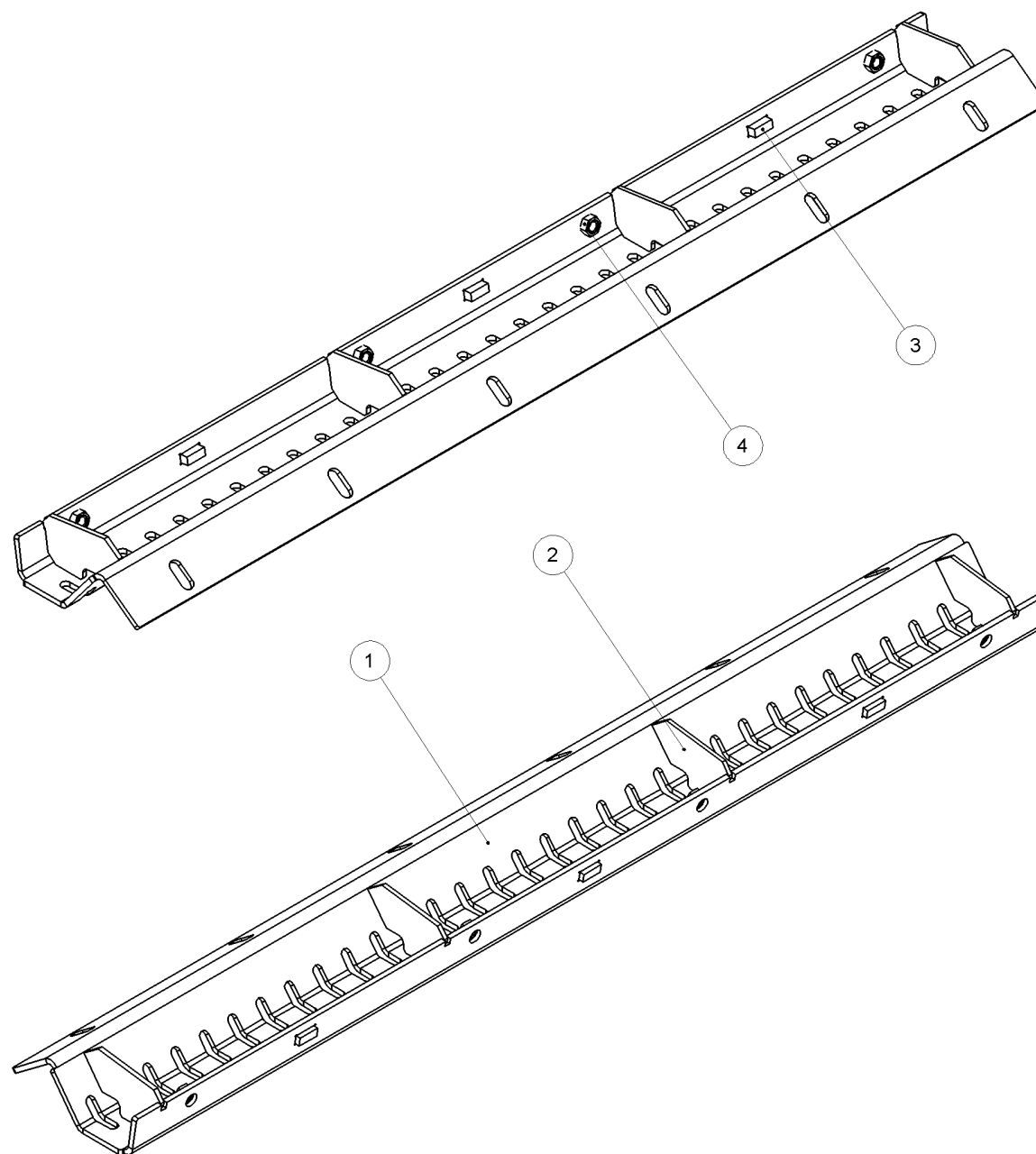

Pos.	Bestell-Nr. Stock Number Numéro de Commande Номер товара	Menge Amount Quantité Количество	Beschreibung	Description	Description	Описание
10	 560.01.19.20.01/00	1,000	TRAEGERBLECH KETTENVORHANG - 1300MM	TRAEGERBLECH KETTENVORHANG - 1300MM	TRAEGERBLECH KETTENVORHANG - 1300MM	
20	 560.01.19.20.02/00	4,000	KNOTENBLECH KETTENVORHANG	KNOTENBLECH KETTENVORHANG	KNOTENBLECH KETTENVORHANG	

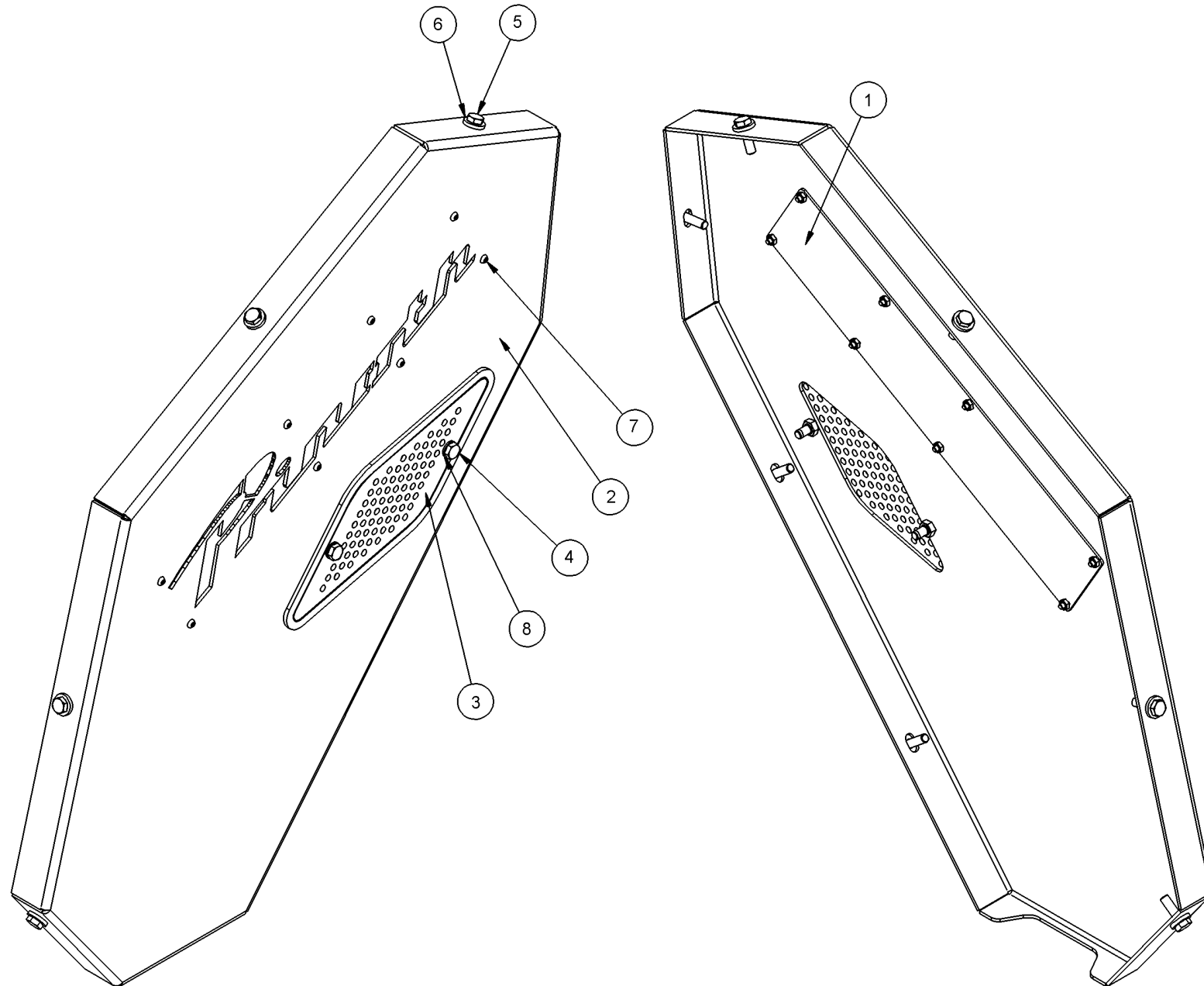

DECKEL-GESCHRAUBT M550 - COVER-SCREWED M550
 COUVERCLE-VISSE M550 - 41387729/00

41387729/00
 Stücklistennummer / Piece Number / Liste de Pièces / Номер



Pos.		Bestell-Nr. Stock Number Numéro de Commande Номер товара	Menge Amount Quantité Количество	Beschreibung	Description	Description	Описание
1		480.01.04.20.00/01	1,000	<u>LOGO-GESCHWEISST</u>	LOGO-WELDED	LOGO-SOUDE	
3		729.01.16.00.01/A	1,000	DECKEL	DECKEL	DECKEL	
4		650.01.15.00.01/00	2,000	<u>SICHERUNGSSCHRAUBE</u>	SICHERUNGSSCHRAUBE	SICHERUNGSSCHRAUBE	
5		01.10.10035	7,000	SKT-SCHRAUBE M10X35 8.8	HEX. SCREW M10X35 DIN933	HEX. SCREW M10X35 DIN933	
6		05.04.10	7,000	SCHEIBE B10,5	WASHER 10,5 - DIN 7349	WASHER 10,5 - DIN 7349	
7		01.40.06016.C.V	8,000	RUNDKOPFSCHRAUBE M6X16 10.9	FILLISTER HEAD SCREW M6X16 DIN	FILLISTER HEAD SCREW M6X16 DIN	
8		05.01.10	2,000	SCHEIBE ISO 7090-10-200HV	WASHER B10,5 DIN 125 GALV.	WASHER B10,5 DIN 125 GALV.	

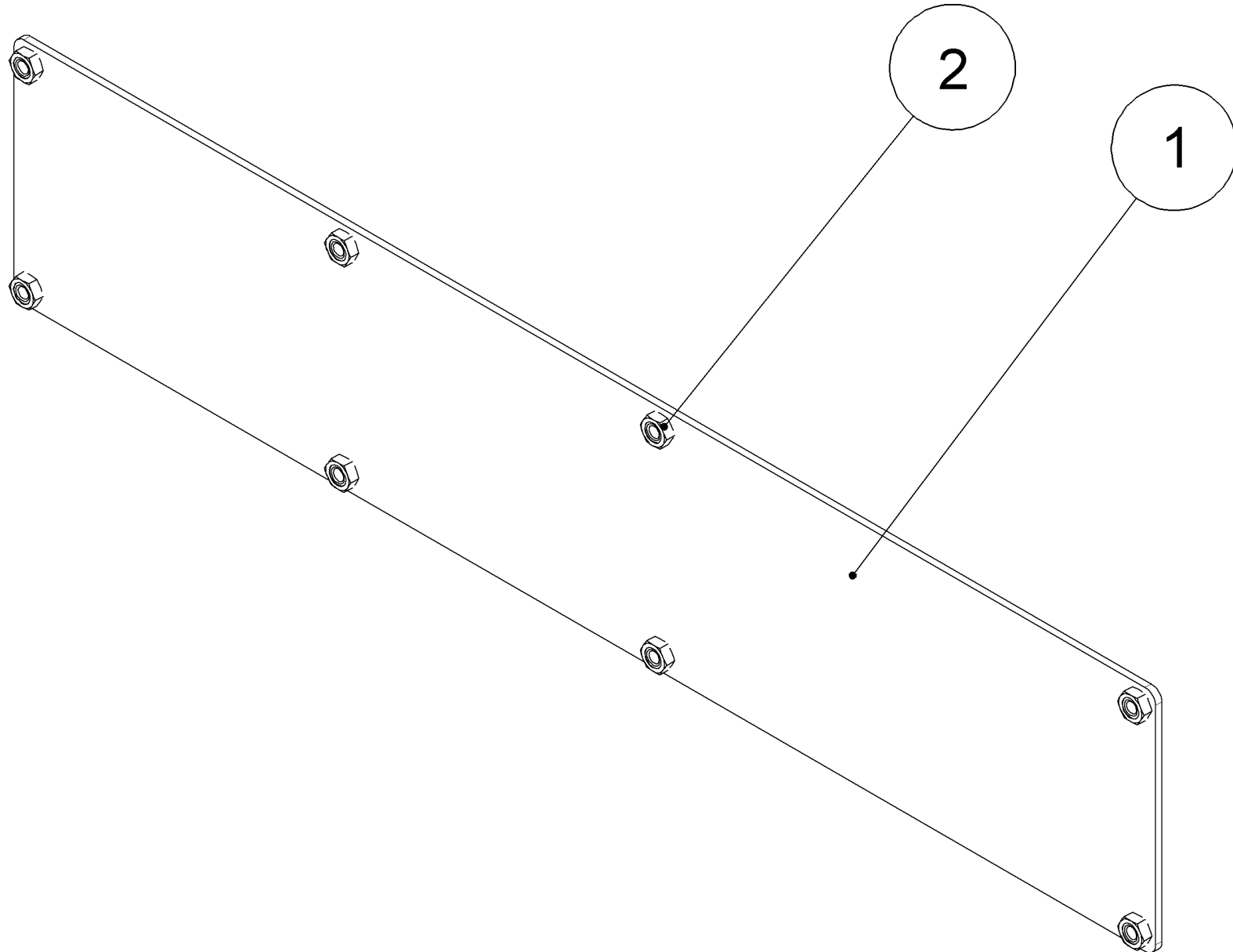

LOGO-GESCHWEISST - LOGO-WELDED
LOGO-SOUDE - 480.01.04.20.00/01

480.01.04.20.00/01
Stücklistennummer / Piece Number / Liste de Pièces / Номер



Pos.	Bestell-Nr. Stock Number Numéro de Commande Номер товара	Menge Amount Quantité Количество	Beschreibung	Description	Description	Описание
------	---	---	--------------	-------------	-------------	----------

10



480.01.04.20.01/01

1,000 BLECH-LOGO

SHEET METAL-LOGO

TOLE-LOGO

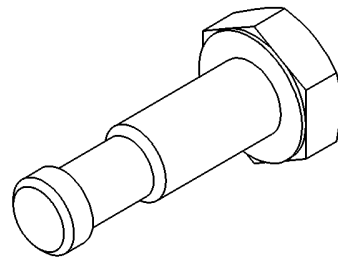

SICHERUNGSSCHRAUBE - SICHERUNGSSCHRAUBE
SICHERUNGSSCHRAUBE - 650.01.15.00.01/00

650.01.15.00.01/00
Stücklistennummer / Piece Number / Liste de Pièces / Номер



Pos.	Bestell-Nr. Stock Number Numéro de Commande Номер товара	Menge Amount Quantité Количество	Beschreibung	Description	Description	Описание
------	---	---	--------------	-------------	-------------	----------

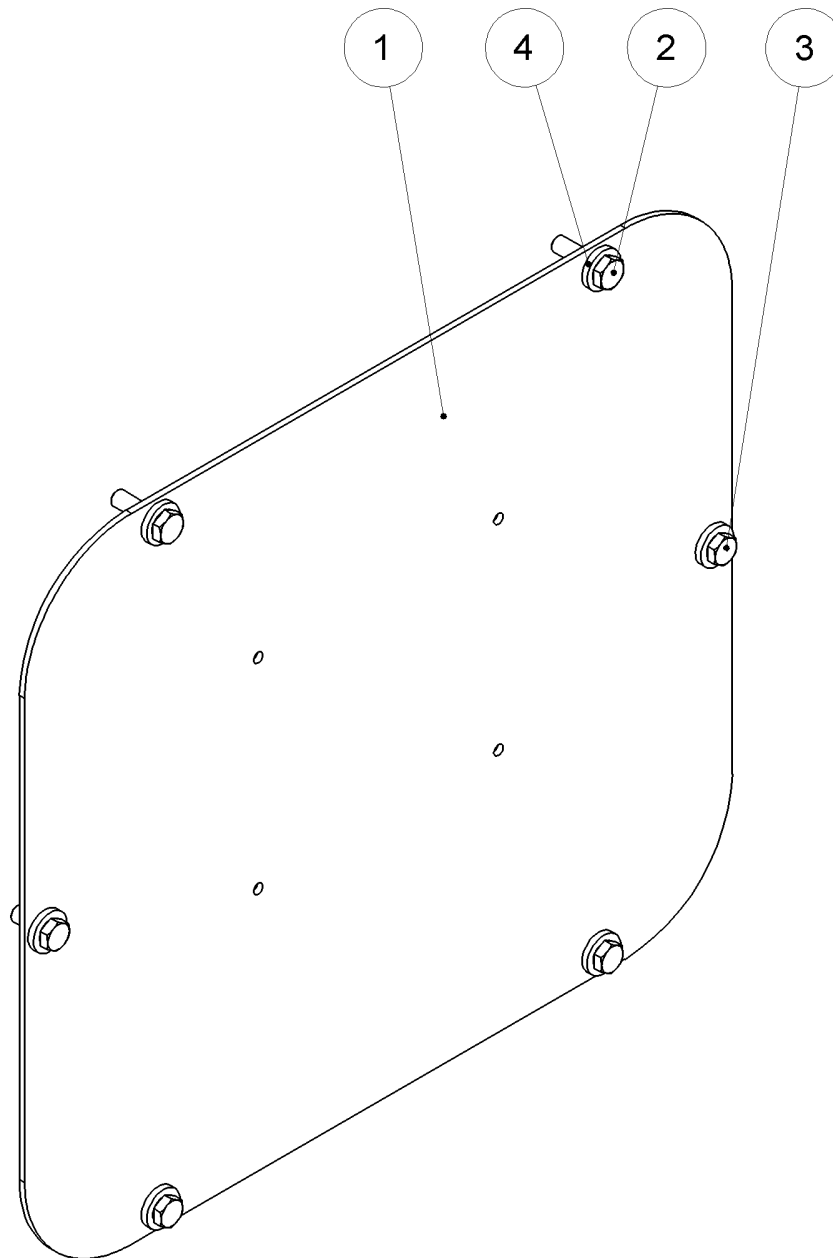

10	 01.10.10035	1,000	SKT-SCHRAUBE M10X35 8.8	HEX. SCREW M10X35 DIN933	HEX. SCREW M10X35 DIN933	
----	---	-------	-------------------------	--------------------------	--------------------------	--



WARTUNGSDECKEL GESCHRAUBT - WARTUNGSDECKEL GESCHRAUBT
 WARTUNGSDECKEL GESCHRAUBT - 560.01.12.00.00/00

560.01.12.00.00/00
 Stücklistennummer / Piece Number / Liste de Pièces / Номер



Pos.		Bestell-Nr. Stock Number Numéro de Commande Номер товара	Menge Amount Quantité Количество	Beschreibung	Description	Description	Описание
10		560.01.12.00.01/00	1,000	WARTUNGSDECKEL	WARTUNGSDECKEL	WARTUNGSDECKEL	
20		01.10.10035	2,000	SKT-SCHRAUBE M10X35 8.8	HEX. SCREW M10X35 DIN933	HEX. SCREW M10X35 DIN933	
30		01.10.10025	4,000	SKT-SCHRAUBE M10X25 8.8	SCREW M10X25 DIN 933	SCREW M10X25 DIN 933	
40		05.04.10	6,000	SCHEIBE B10,5	WASHER 10,5 - DIN 7349	WASHER 10,5 - DIN 7349	

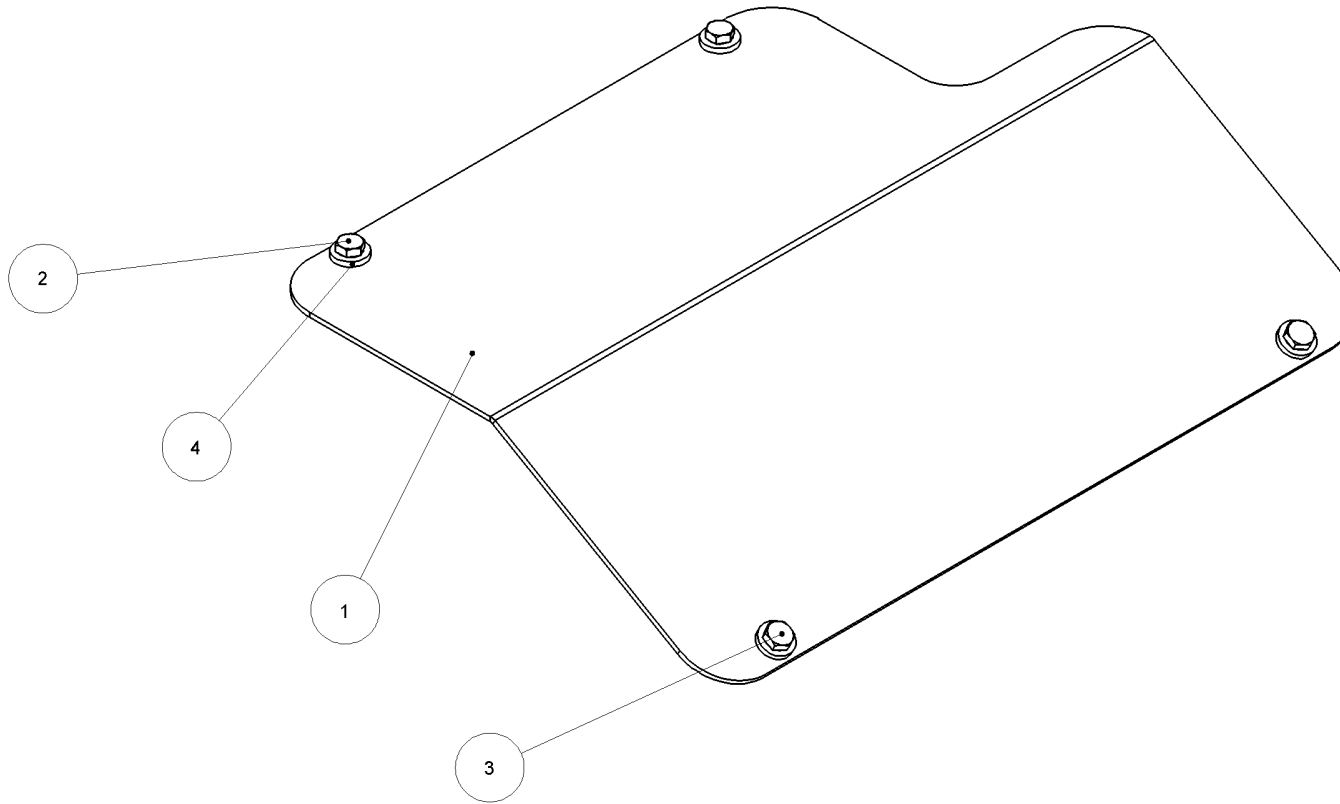

BOM:560.00.00.00.00 MAT: 560.01.12.03.00 DRW/560.01.12.03.00/DE/00 10005427 2020-07-16

WARTUNGSDECKEL GESCHRAUBT - WARTUNGSDECKEL GESCHRAUBT
 WARTUNGSDECKEL GESCHRAUBT - 560.01.12.03.00/00

560.01.12.03.00/00
 Stücklistennummer / Piece Number / Liste de Pièces / Номер



Pos.		Bestell-Nr. Stock Number Numéro de Commande Номер товара	Menge Amount Quantité Количество	Beschreibung	Description	Description	Описание
10		560.01.12.03.01/00	1,000	WARTUNGSDECKEL	WARTUNGSDECKEL	WARTUNGSDECKEL	
20		01.10.10025	2,000	SKT-SCHRAUBE M10X25 8.8	SCREW M10X25 DIN 933	SCREW M10X25 DIN 933	
30		01.10.10035	2,000	SKT-SCHRAUBE M10X35 8.8	HEX. SCREW M10X35 DIN933	HEX. SCREW M10X35 DIN933	
40		05.04.10	4,000	SCHEIBE B10,5	WASHER 10,5 - DIN 7349	WASHER 10,5 - DIN 7349	

WARTUNGSDECKEL GESCHRAUBT - WARTUNGSDECKEL GESCHRAUBT
WARTUNGSDECKEL GESCHRAUBT - 560.01.12.01.00/00

560.01.12.01.00/00



Stücklistennummer / Piece Number / Liste de Pièces / Homep



WARTUNGSDECKEL GESCHRAUBT - WARTUNGSDECKEL GESCHRAUBT
 WARTUNGSDECKEL GESCHRAUBT - 560.01.12.01.00/00

560.01.12.01.00/00
 Stücklistennummer / Piece Number / Liste de Pièces / Номер



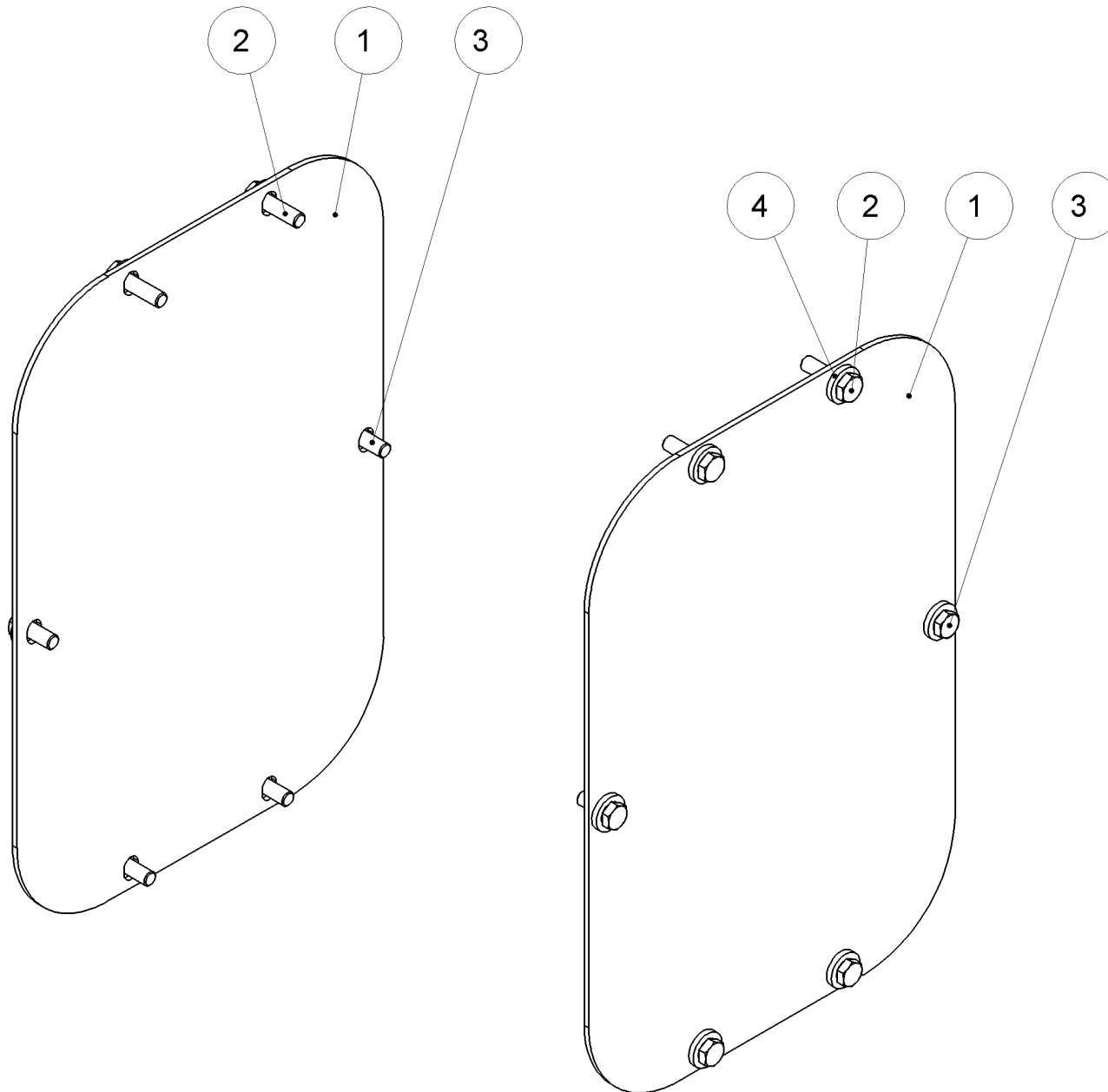

Pos.		Bestell-Nr. Stock Number Numéro de Commande Номер товара	Menge Amount Quantité Количество	Beschreibung	Description	Description	Описание
10		560.01.12.01.01/00	1,000	WARTUNGSDECKEL	WARTUNGSDECKEL	WARTUNGSDECKEL	
20		01.10.10035	2,000	SKT-SCHRAUBE M10X35 8.8	HEX. SCREW M10X35 DIN933	HEX. SCREW M10X35 DIN933	
30		01.10.10025	4,000	SKT-SCHRAUBE M10X25 8.8	SCREW M10X25 DIN 933	SCREW M10X25 DIN 933	
40		05.04.10	6,000	SCHEIBE B10,5	WASHER 10,5 - DIN 7349	WASHER 10,5 - DIN 7349	



WARTUNGSDECKEL GESCHRAUBT - WARTUNGSDECKEL GESCHRAUBT
 WARTUNGSDECKEL GESCHRAUBT - 560.01.12.02.00/00

560.01.12.02.00/00
 Stücklistennummer / Piece Number / Liste de Pièces / Номер



Pos.		Bestell-Nr. Stock Number Numéro de Commande Номер товара	Menge Amount Quantité Количество	Beschreibung	Description	Description	Описание
10		560.01.12.02.01/00	1,000	WARTUNGSDECKEL	WARTUNGSDECKEL	WARTUNGSDECKEL	
20		01.10.10035	2,000	SKT-SCHRAUBE M10X35 8.8	HEX. SCREW M10X35 DIN933	HEX. SCREW M10X35 DIN933	
30		01.10.10025	4,000	SKT-SCHRAUBE M10X25 8.8	SCREW M10X25 DIN 933	SCREW M10X25 DIN 933	
40		05.04.10	6,000	SCHEIBE B10,5	WASHER 10,5 - DIN 7349	WASHER 10,5 - DIN 7349	

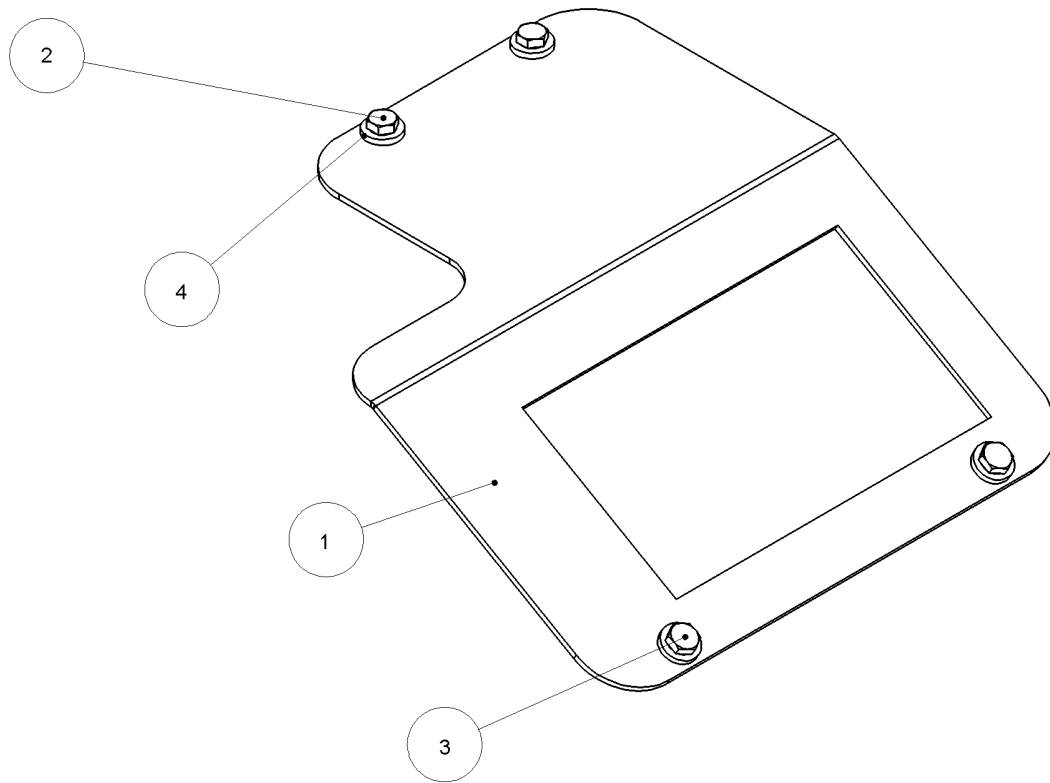

BOM:560.00.00.00.00 MAT: 560.01.12.04.00 DRW/560.01.12.04.00/DE/00 I0005427 2020-07-16

WARTUNGSDECKEL GESCHRAUBT - WARTUNGSDECKEL GESCHRAUBT
 WARTUNGSDECKEL GESCHRAUBT - 560.01.12.04.00/00

560.01.12.04.00/00
 Stücklistennummer / Piece Number / Liste de Pièces / Номер





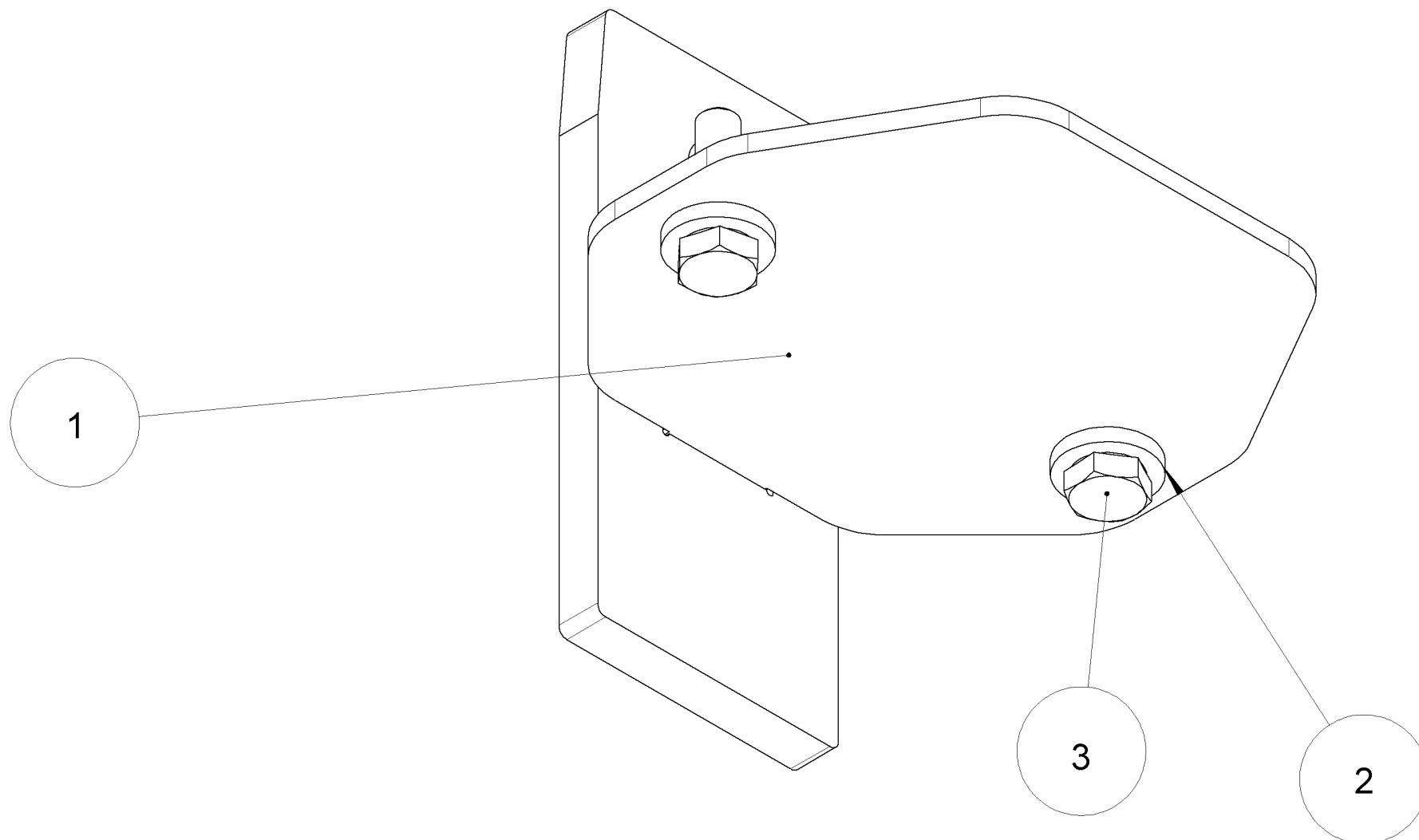



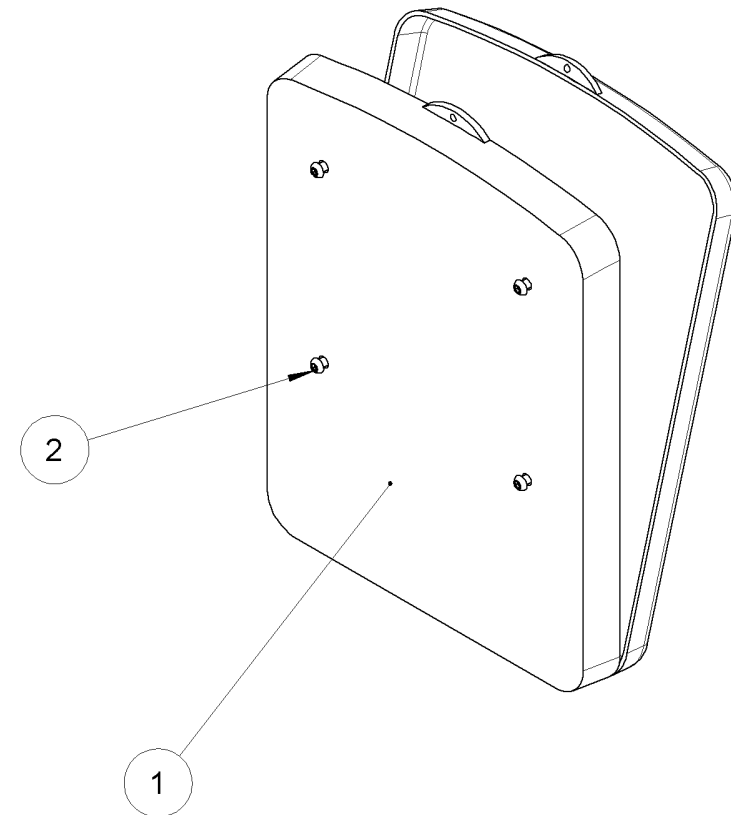
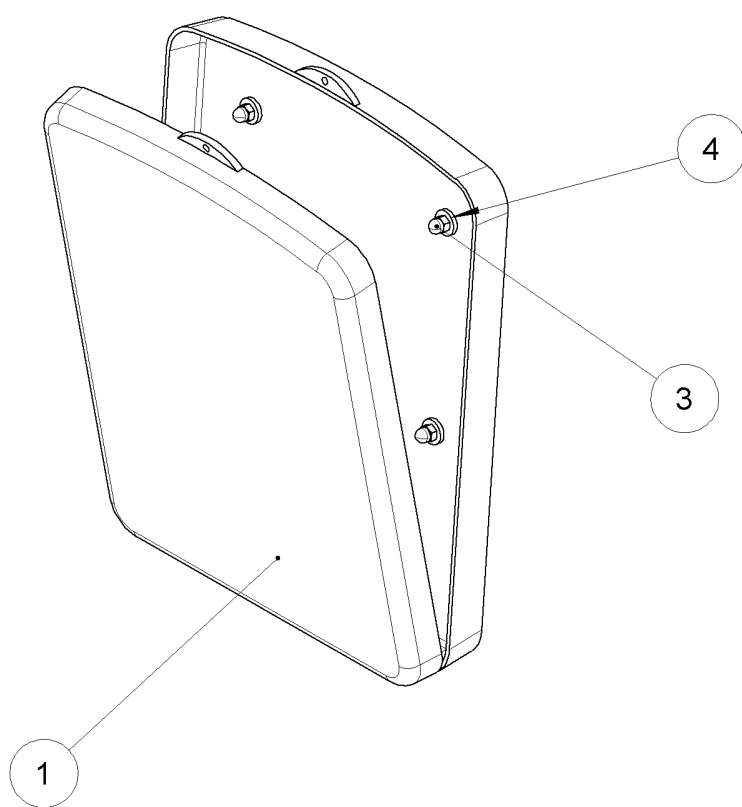

Pos.	Bestell-Nr. Stock Number Numéro de Commande Номер товара	Menge Amount Quantité Количество	Beschreibung	Description	Description	Описание
10	 560.01.12.04.01/00	1,000	WARTUNGSDECKEL	WARTUNGSDECKEL	WARTUNGSDECKEL	
20	 01.10.10025	2,000	SKT-SCHRAUBE M10X25 8.8	SCREW M10X25 DIN 933	SCREW M10X25 DIN 933	
30	 01.10.10035	2,000	SKT-SCHRAUBE M10X35 8.8	HEX. SCREW M10X35 DIN933	HEX. SCREW M10X35 DIN933	
40	 05.04.10	4,000	SCHEIBE B10,5	WASHER 10,5 - DIN 7349	WASHER 10,5 - DIN 7349	



Pos.	Bestell-Nr. Stock Number Numéro de Commande Номер товара	Menge Amount Quantité Количество	Beschreibung	Description	Description	Описание
10	 551.01.17.21.00/B	1,000	ROTORSCHLITZ GESCHWEISST	ROTORSCHLITZ GESCHWEISST	ROTORSCHLITZ GESCHWEISST	
20	 05.04.10	2,000	SCHEIBE B10,5	WASHER 10,5 - DIN 7349	WASHER 10,5 - DIN 7349	
30	 01.10.10035	2,000	SKT-SCHRAUBE M10X35 8.8	HEX. SCREW M10X35 DIN933	HEX. SCREW M10X35 DIN933	



Pos.		Bestell-Nr. Stock Number Numéro de Commande Номер товара	Menge Amount Quantité Количество	Beschreibung	Description	Description	Описание
10		71.001.155/00	1,000	DOKUMENTENHALTER	DOKUMENTENHALTER	DOKUMENTENHALTER	
20		01.40.06016.C.V	4,000	RUNDKOPFSCHRAUBE M6X16 10.9	FILLISTER HEAD SCREW M6X16 DIN	FILLISTER HEAD SCREW M6X16 DIN	
30		03.15.06	4,000	HUTMUTTER M6	CAP NUT M6 DIN1587	CAP NUT M6 DIN1587	
40		05.04.06	4,000	SCHEIBE B6,4	WASHER B6,4 DIN 7349 GALV.	WASHER B6,4 DIN 7349 GALV.	

	PRINOTH GmbH D-88634 Herdwangen Im Branden 15
Maschinenbezeichnung:	<input type="text"/>
Maschinentyp:	<input type="text"/>
Seriennummer:	<input type="text"/>
Artikelnummer:	<input type="text"/>
Gesamtgewicht:	<input type="text"/>
Baujahr:	<input type="text"/>
 Made in Germany	www.prinoth.com   



1

2

TYPENSCHILD + NIETEN - TYPENSCHILD + NIETEN
TYPENSCHILD + NIETEN - 551.01.00.90.00/00

551.01.00.90.00/00
Stücklistennummer / Piece Number / Liste de Pièces / Номер



Pos.	Bestell-Nr. Stock Number Numéro de Commande Номер товара	Menge Amount Quantité Количество	Beschreibung	Description	Description	Описание
10	 85.003.001/04	1,000	TYPENSCHILD-CE KENNZEICHNUNG	IDENTIFICATION PLATE-CE MARKING	PLAQUE SIGNALETIQUE- MARQUAGE CE	
20	 84.110.03.12/00	4,000	BLINDNIETE 3,2X12 KLEMMB. 7-9,FLACHK.	BLIND RIVET	BLIND RIVET	

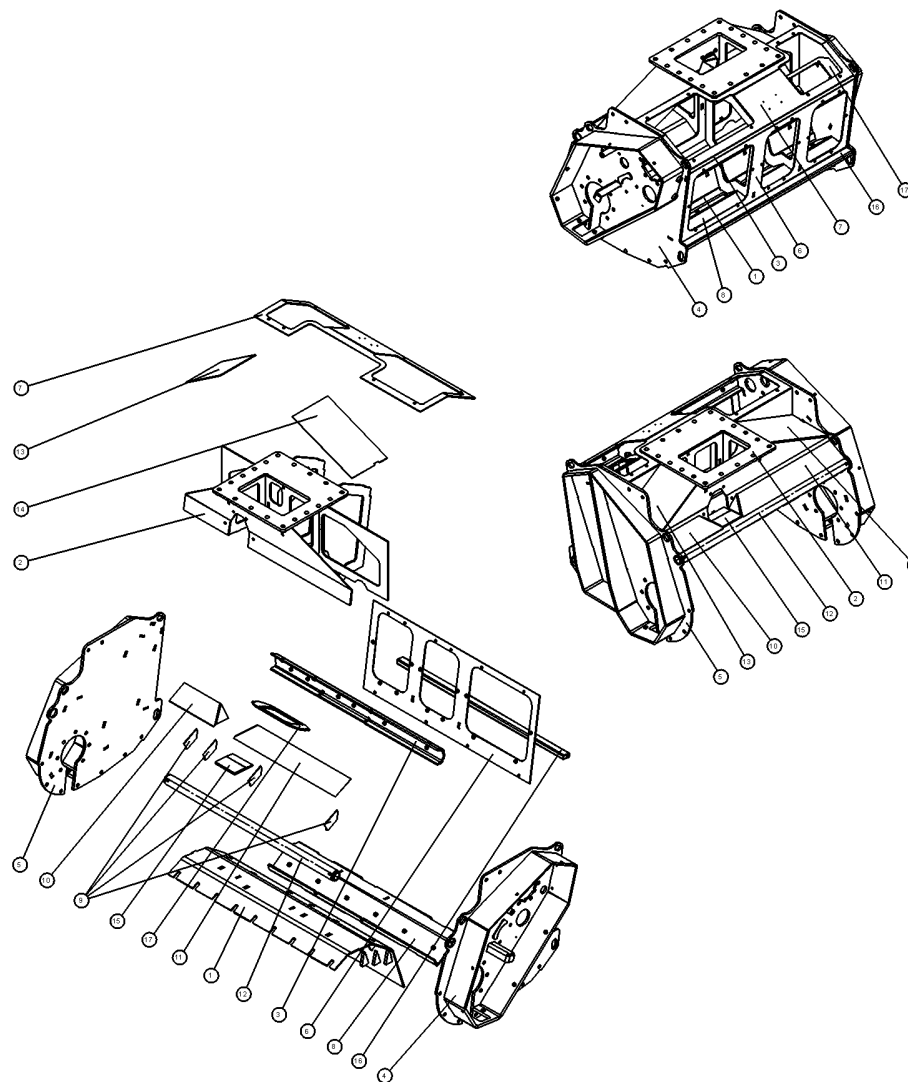

Pos.	Bestell-Nr. Stock Number Numéro de Commande Номер товара	Menge Amount Quantité Количество	Beschreibung	Description	Description	Описание
------	---	---	--------------	-------------	-------------	----------

20



560.01.01.21.00/B

1,000

KONSOLE GESCHWEISST

KONSOLE GESCHWEISST

KONSOLE GESCHWEISST

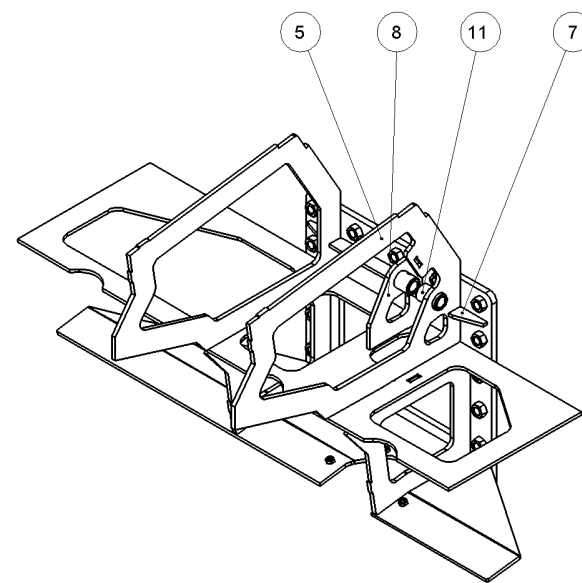
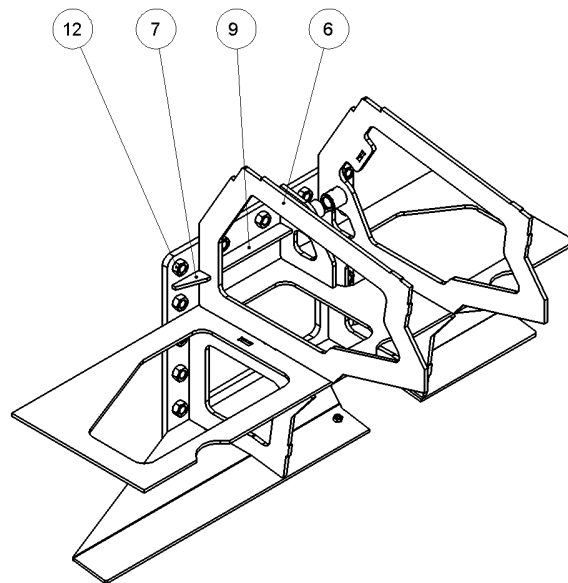
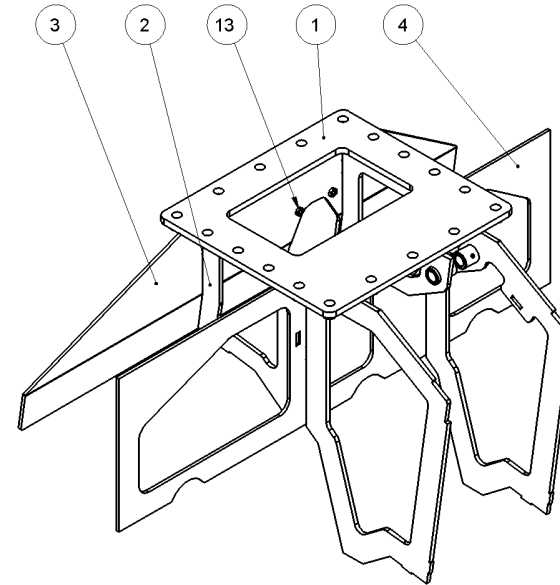
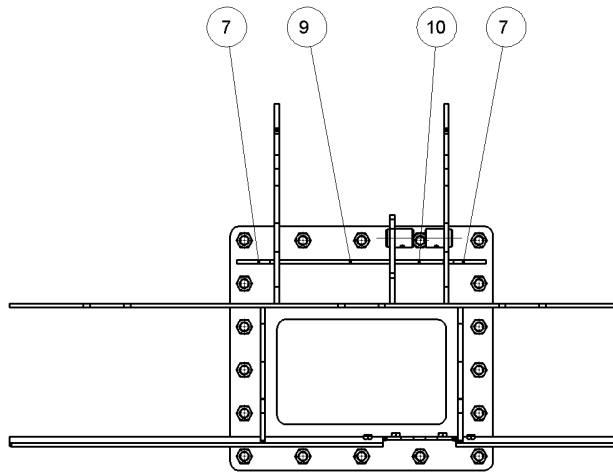

KONSOLE GESCHWEISST - KONSOLE GESCHWEISST
KONSOLE GESCHWEISST - 560.01.01.21.00/B

560.01.01.21.00/B
Stücklistennummer / Piece Number / Liste de Pièces / Номер



Pos.	Bestell-Nr. Stock Number Numéro de Commande Номер товара	Menge Amount Quantité Количество	Beschreibung	Description	Description	Описание
------	---	---	--------------	-------------	-------------	----------



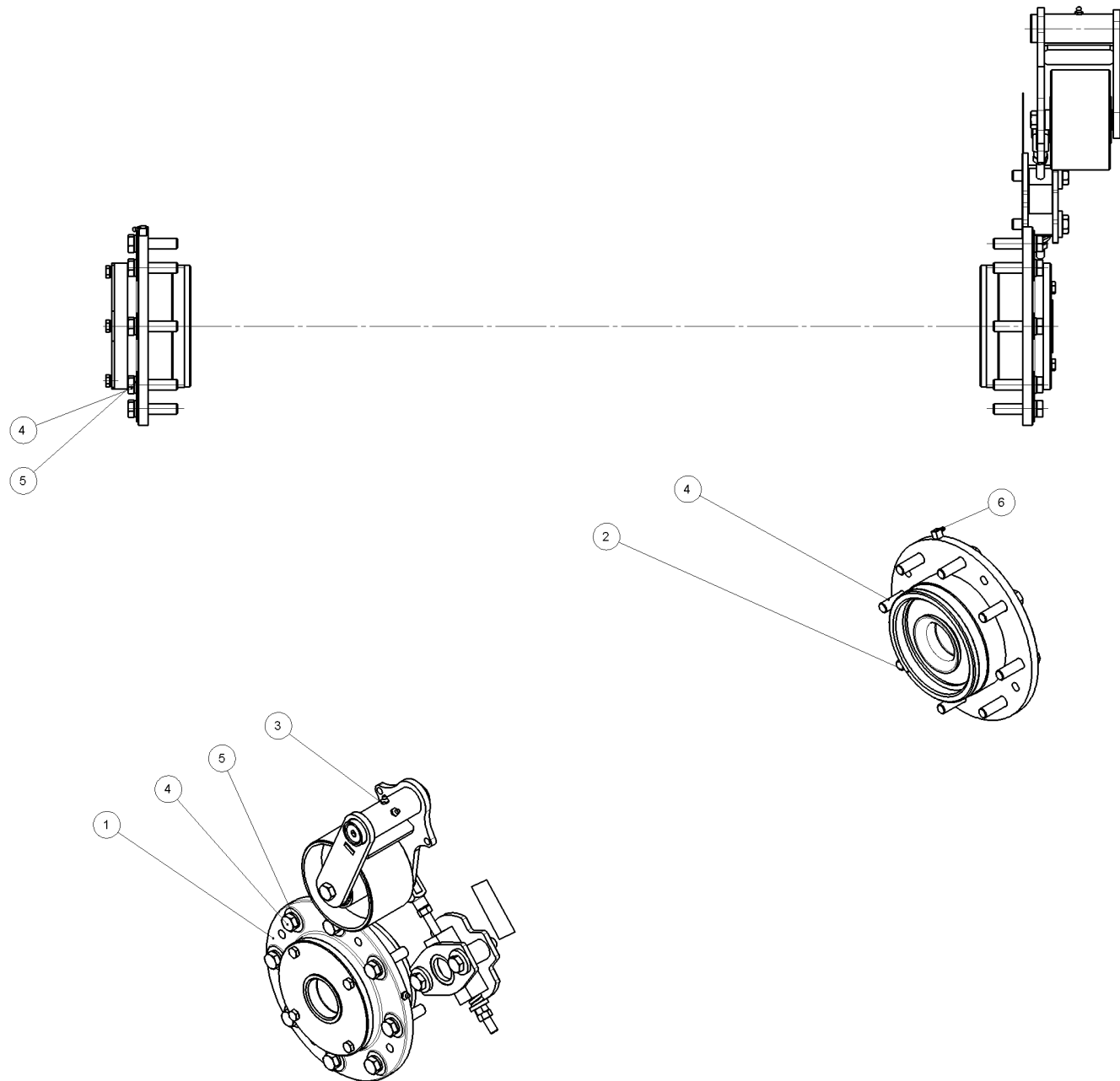



120	 03.01.20	18,0- 00	SKT-MUTTER M20 8	NUT M20 DIN 934	NUT M20 DIN 934	
-----	--	-------------	------------------	-----------------	-----------------	--



ANTRIEB EINSEITIG - OHNE HYDR.-MOTOR - DRIVE W/O HYD. MOTOR - 1 SIDE
 DRIVE W/O HYD. MOTOR - 1 SIDE - 560.02.00.00/01

560.02.00.00/01
 Stücklistennummer / Piece Number / Liste de Pièces / Homep



Pos.		Bestell-Nr. Stock Number Numéro de Commande Номер товара	Menge Amount Quantité Количество	Beschreibung	Description	Description	Описание
10		013.01.2.00/00	1,000	FESTLAGER D65X140 SCHRAUBB. STU. IR 31	FIXED BEARING D65/140 FM600PR.	FIXED BEARING D65/140 FM600PR.	
20		013.02.3.00/00	1,000	LOSLAGER D65X140 - DISTANZRING 31	LOSLAGER D65X140 - DISTANZRING 31	LOSLAGER D65X140 - DISTANZRING 31	
30		41323484/00	1,000	SPANNROLLE-AUSSEN	TENSIONING PULLEY-OUTSIDE	POULIE DE TENSION- EXTERIEUR	
40		01.10.16065	16,0- 00	SKT-SCHRAUBE M16X65 8.8	HEX. SCREW M16X65 DIN933	HEX. SCREW M16X65 DIN933	
50		07.02.16	16,0- 00	NORD-LOCK-SCHEIBE FUER M16	NORD-LOCK-DISC FOR M16	NORD-LOCK-DISC FOR M16	
60		24.C.10.100	1,000	SCHMIERNIPPEL M10X1 90G 90 GRAD	GRASE NIPPLE	GRASE NIPPLE	

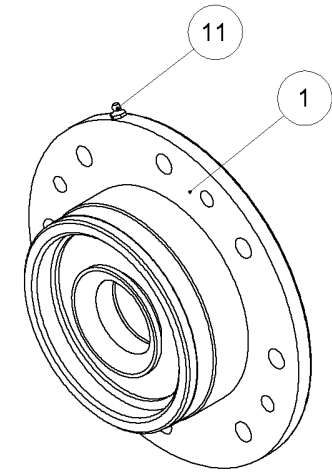
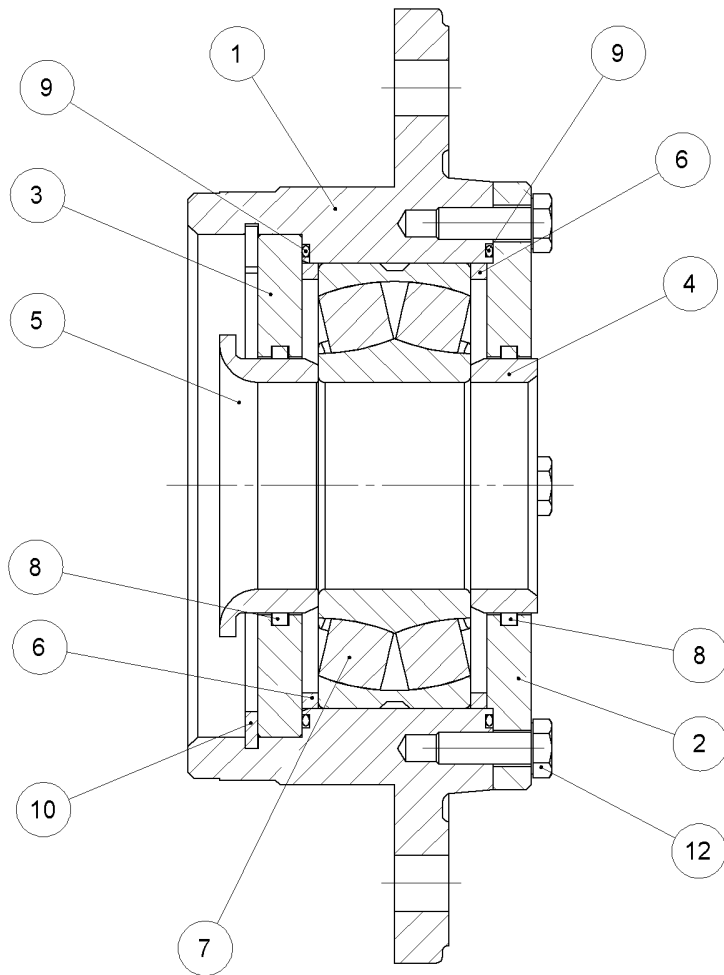

Pos.		Bestell-Nr. Stock Number Numéro de Commande Номер товара	Menge Amount Quantité Количество	Beschreibung	Description	Description	Описание
10		013.01.0.01/C	1,000	LAGERGEHAEUSE GGG40. FERTIG BEARBEITET	SIEHE 13.01.0.01.F	SIEHE 13.01.0.01.F	
20		013.01.0.02/00	1,000	DECKEL LAGERGEHAEUSE	COVER FOR HOUSING	COVER FOR HOUSING	
30		013.01.0.03/00	1,000	INNENDECKEL	INNER COVER D65/140	INNER COVER D65/140	
40		013.01.0.04/00	1,000	DISTANZRING D80X65X21	DISTANCE RING /SPACER 65/80X21	DISTANCE RING /SPACER 65/80X21	
50		013.01.2.05/A	1,000	DISTANZRING D95X65X31	DISTANCE RING	DISTANCE RING	
60		14.03.002/00	2,000	FESTRING FRM140X5	FIXED RING FRM140X5	FIXED RING FRM140X5	
70		13.A.0004/00	1,000	PENDELKUGELLAGER	SELF ALIGNING BALL BEARING	ROULEMENT A ROTULE SUR BILLE	
80		14.05.ISKD080/00	2,000	LAMELLENRING 3,5X1,65 D80	LAMELLA RING	LAMELLA RING	
90		19.03.144.00.3.00	2,000	O-RING 144,00X3,00	O-RING D144X3	O-RING D144X3	
100		16.01.J160	1,000	SICHERUNGSRING J160X4,0	RETAINING RING J160	RETAINING RING J160	
110		24.A.10.100	1,000	SCHMIERNIPPEL M10X1 GERADE, STAHL	LUBRICATING NIPPLE M10X1	LUBRICATING NIPPLE M10X1	

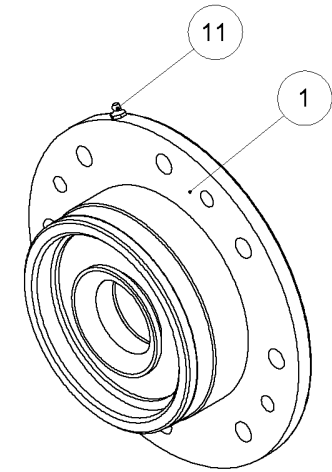
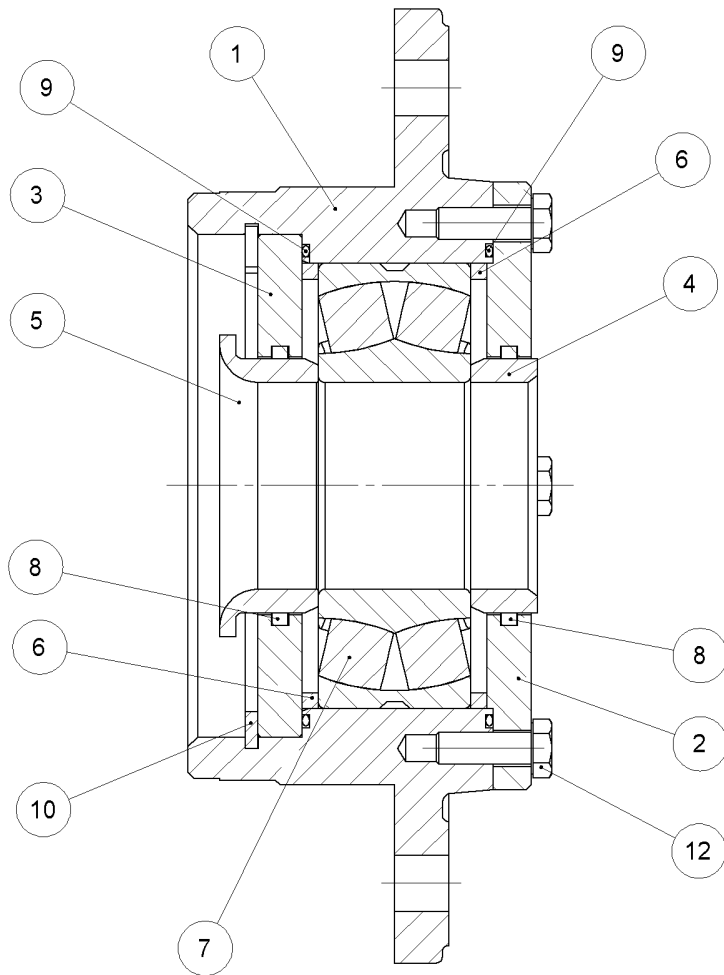

FESTLAGER D65X140 SCHRAUBB. STU. IR 31 - FIXED BEARING D65/140 FM600PR.
FIXED BEARING D65/140 FM600PR. - 013.01.2.00/00

013.01.2.00/00

Stücklistennummer / Piece Number / Liste de Pièces / Номер



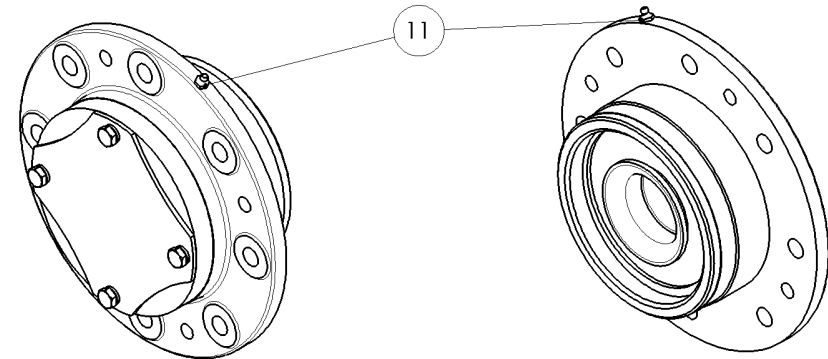
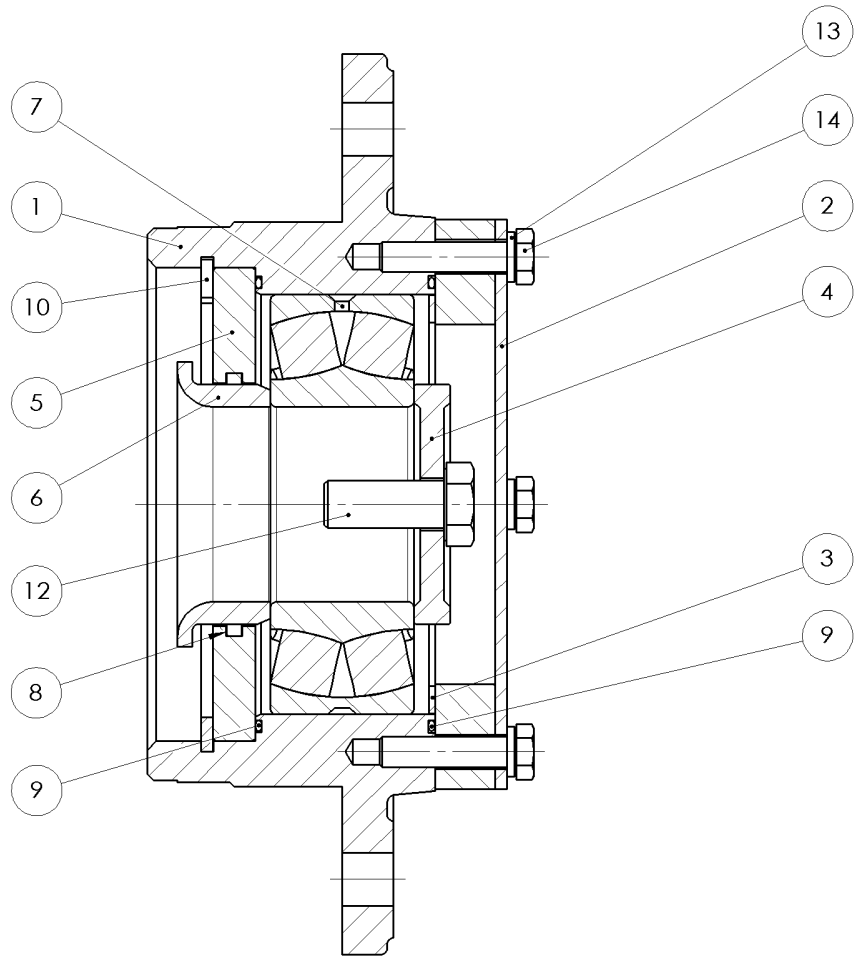

Pos.	Bestell-Nr. Stock Number Numéro de Commande Номер товара	Menge Amount Quantité Количество	Beschreibung	Description	Description	Описание
120	 01.10.10030	4,000	SKT-SCHRAUBE M10X30 8.8	HEX. SCREW M10X30 DIN 933	HEX. SCREW M10X30 DIN 933	

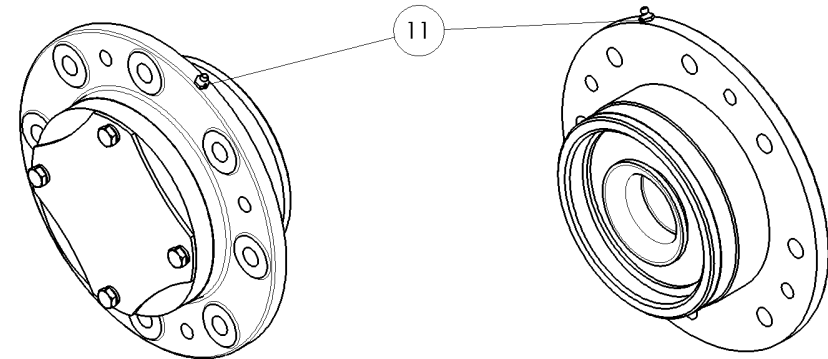
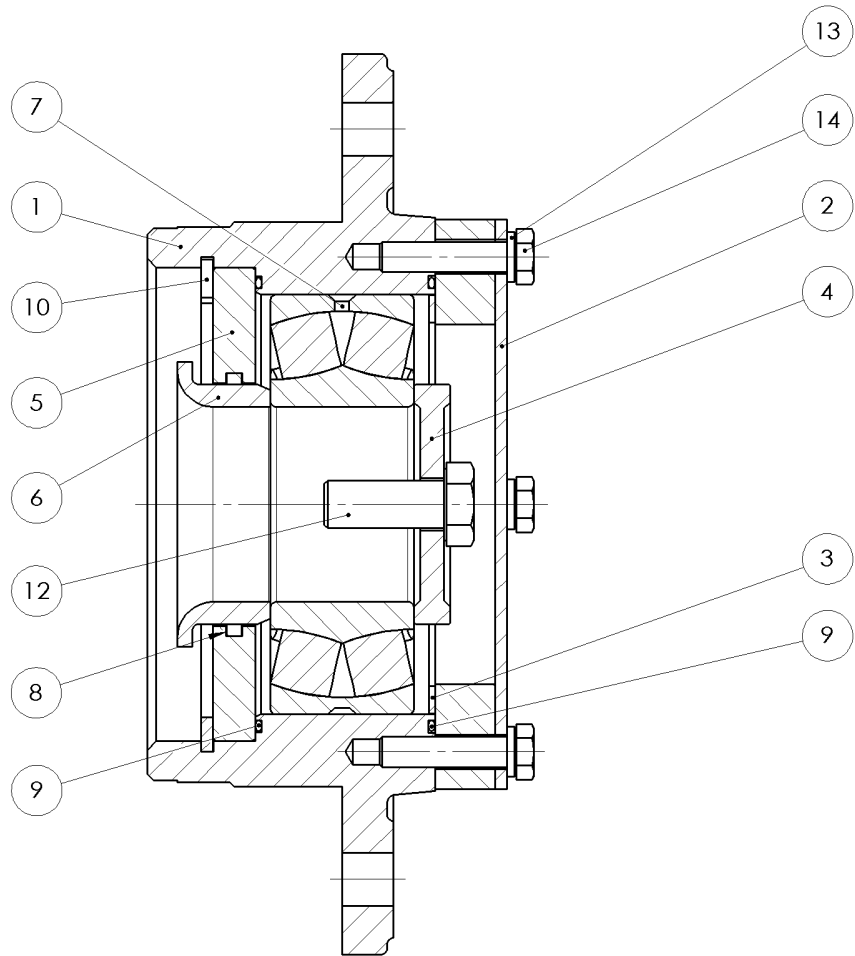

Pos.		Bestell-Nr. Stock Number Numéro de Commande Номер товара	Menge Amount Quantité Количество	Beschreibung	Description	Description	Описание
10		013.01.0.01/C	1,000	LAGERGEHAEUSE GGG40. FERTIG BEARBEITET	SIEHE 13.01.0.01.F	SIEHE 13.01.0.01.F	
20		013.02.3.20/00	1,000	LAGERDECKEL GESCHLOSSEN - GESCHWEISST	LAGERDECKEL GESCHLOSSEN - GESCHWEISST	LAGERDECKEL GESCHLOSSEN - GESCHWEISST	
30		013.02.3.03/00	1,000	DISTANZRING D139.5 X D121 X 2	DISTANZRING D139.5 X D121 X 2	DISTANZRING D139.5 X D121 X 2	
40		013.02.3.04/00	1,000	SPANNSCHEIBE D80 X D17.5 X 12	SPANNSCHEIBE D80 X D17.5 X 12	SPANNSCHEIBE D80 X D17.5 X 12	
50		013.01.0.03/00	1,000	INNENDECKEL	INNER COVER D65/140	INNER COVER D65/140	
60		013.01.2.05/A	1,000	DISTANZRING D95X65X31	DISTANCE RING	DISTANCE RING	
70		13.A.0004/00	1,000	PENDELKUGELLAGER	SELF ALIGNING BALL BEARING	ROULEMENT A ROTULE SUR BILLE	
80		14.05.ISKD080/00	1,000	LAMELLENRING 3,5X1,65 D80	LAMELLA RING	LAMELLA RING	
90		19.03.144.00.3.00	2,000	O-RING 144,00X3,00	O-RING D144X3	O-RING D144X3	
100		16.01.J160	1,000	SICHERUNGSRING J160X4,0	RETAINING RING J160	RETAINING RING J160	
110		24.A.10.100	1,000	SCHMIERNIPPEL M10X1 GERADE, STAHL	LUBRICATING NIPPLE M10X1	LUBRICATING NIPPLE M10X1	



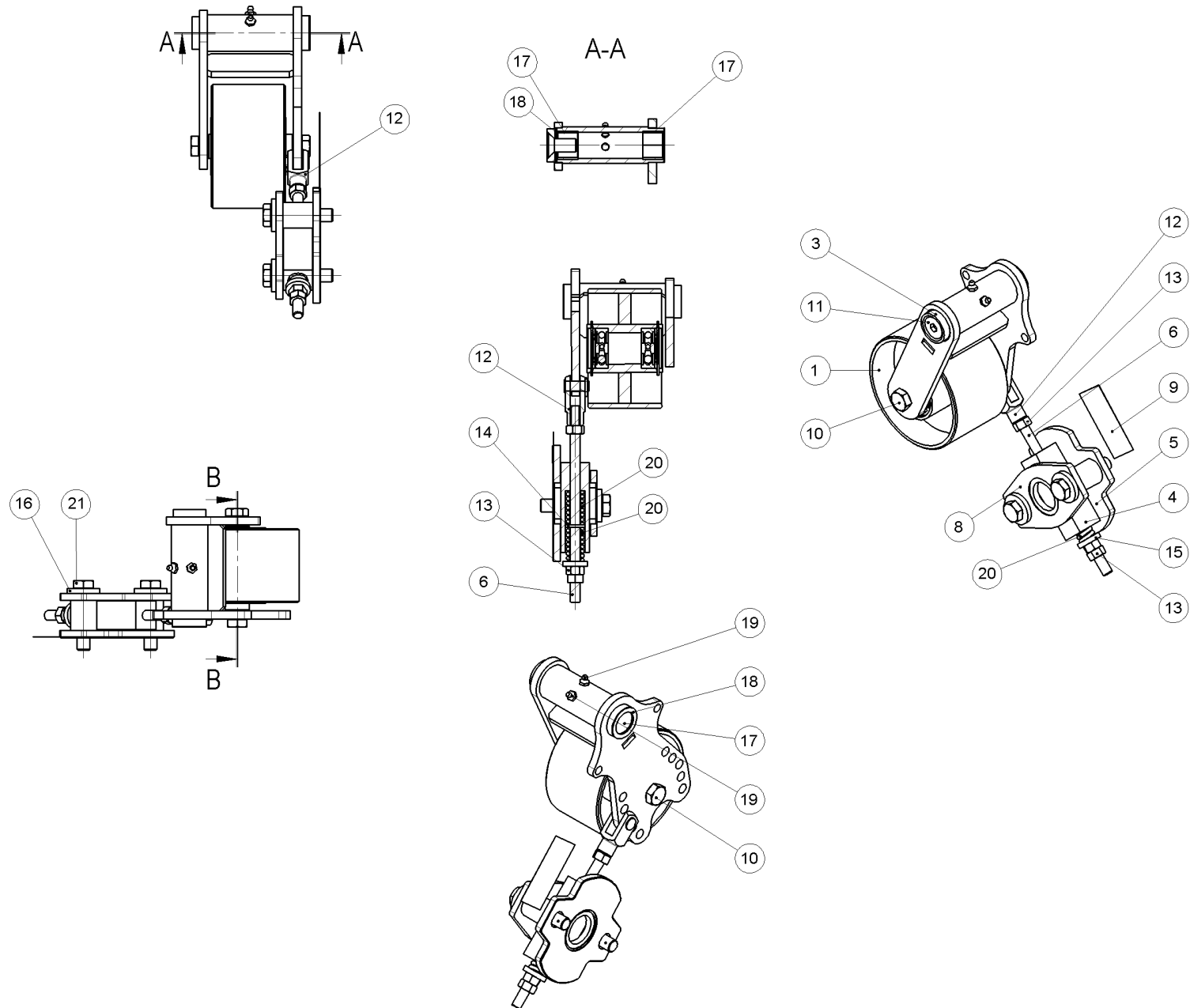

Pos.		Bestell-Nr. Stock Number Numéro de Commande Номер товара	Menge Amount Quantité Количество	Beschreibung	Description	Description	Описание
120		01.10.16040	1,000	SKT-SCHRAUBE M16X40 8.8	HEX. SCREW M16X40 DIN933	HEX. SCREW M16X40 DIN933	
130		07.02.10	4,000	NORD-LOCK-SCHEIBE FUER M10	NORD-LOCK-DISC FOR M10	NORD-LOCK-DISC FOR M10	
140		01.10.10045	4,000	SKT-SCHRAUBE M10X45 8.8	SCREW M10X45 DIN 933	SCREW M10X45 DIN 933	



SPANNROLLE-AUSSEN - TENSIONING PULLEY-OUTSIDE
POULIE DE TENSION-EXTERIEUR - 41323484/00

41323484/00
Stücklistennummer / Piece Number / Liste de Pièces / Homep



Pos.	Bestell-Nr. Stock Number Numéro de Commande Номер товара	Menge Amount Quantité Количе- ство	Beschreibung	Description	Description	Описание
10	41325311/00	1,000	SPANNROLLE	TENSIONING PULLEY	POULIE DE TENSION	
20	 551.02.01.20.00/C	1,000	AUFNAHME SPANNROLLE GESCHWEISST	AUFNAHME SPANNROLLE GESCHWEISST	AUFNAHME SPANNROLLE GESCHWEISST	
30	 650.02.01.00.01/00	1,000	SCHEIBE	SCHEIBE	SCHEIBE	
40	 650.02.04.27.00/A	1,000	HALTER FEDERPAKET	HALTER FEDERPAKET	HALTER FEDERPAKET	
50	 650.02.04.27.01/00	1,000	HALTER RUECKSEITE RIEMENSPANNER	HALTER RUECKSEITE RIEMENSPANNER	HALTER RUECKSEITE RIEMENSPANNER	
60	 650.02.04.27.06/A	1,000	RUNDSTAHL MIT GEWINDE	THREADED ROD	THREADED ROD	
70	 650.02.04.27.09/00	1,000	DISTANZ RIEMENSPANNER	DISTANZ RIEMENSPANNER	DISTANZ RIEMENSPANNER	
80	 650.02.04.28.00/00	1,000	HALTER GEGENLAGER	HALTER GEGENLAGER	HALTER GEGENLAGER	
90	 85.01.151/01	1,000	AUFKLEBER-RIEMENSPANNER	STICKER-BELT TAKEUP	AUTOCOLLANT-TENDEUR DE COURROIE	
100	 01.10.16035	2,000	SKT-SCHRAUBE M16X35 8.8	SCREW M16X35 DIN 933	SCREW M16X35 DIN 933	
110	 01.30.16035.C.V	1,000	SENKSCHRAUBE M16X35 10.9	COUNTERSUNK HEAD SCREW M16X35	COUNTERSUNK HEAD SCREW M16X35	

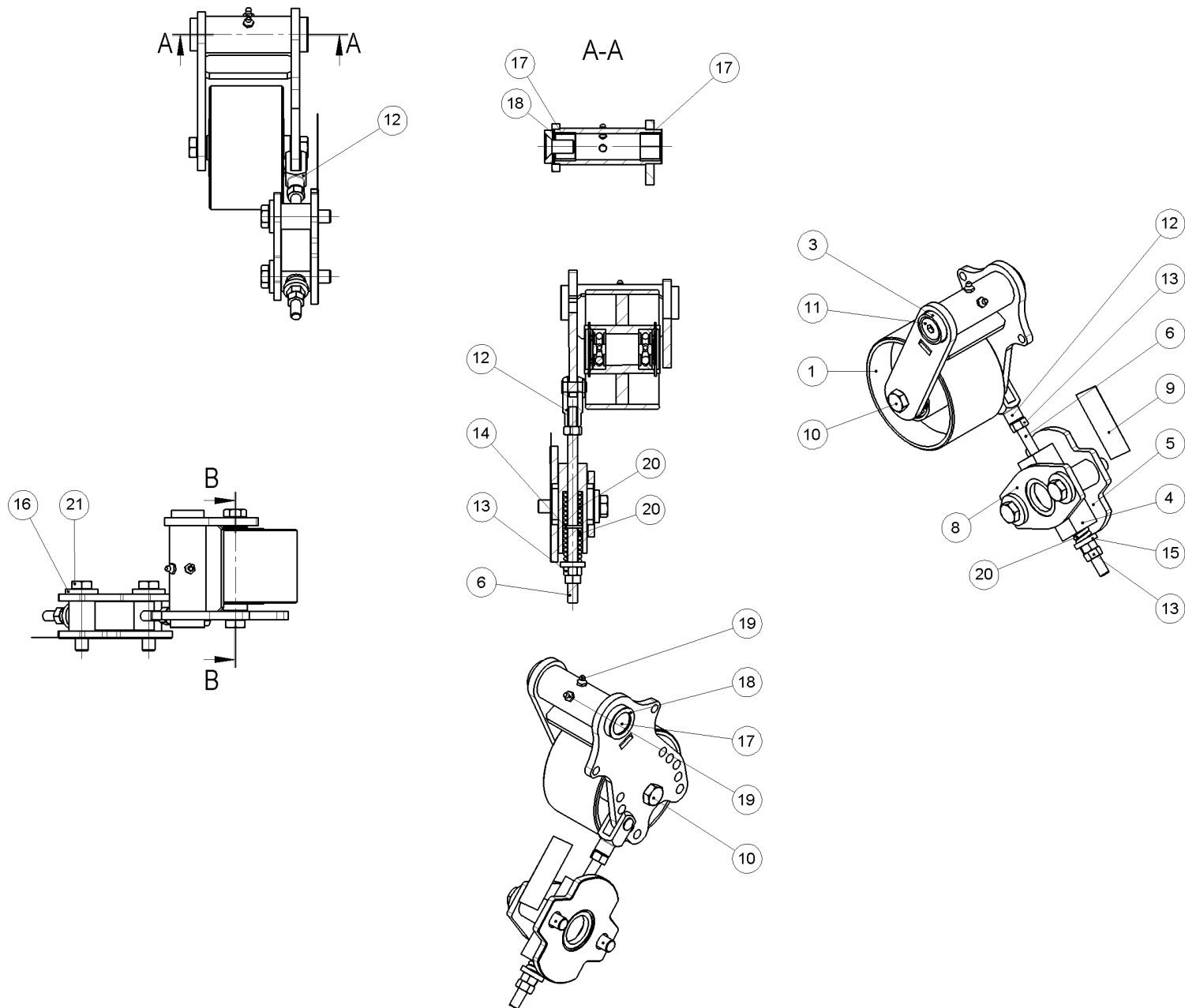











SPANNROLLE-AUSSEN - TENSIONING PULLEY-OUTSIDE
POULIE DE TENSION-EXTERIEUR - 41323484/00

41323484/00

Stücklistennummer / Piece Number / Liste de Pièces / Homep



Pos.		Bestell-Nr. Stock Number Numéro de Commande Номер товара	Menge Amount Quantité Количество	Beschreibung	Description	Description	Описание
120		02.01.08/A	1,000	GELENKKOPF	JOINT HEAD	TETE ARTICULEE	
130		03.01.12	3,000	SKT-MUTTER M12 8	NUT M12 DIN 934	NUT M12 DIN 934	
140		05.01.13	1,000	SCHEIBE ISO 7090-13-200HV	WASHER B13 DIN 125 GALVANIZED	WASHER B13 DIN 125 GALVANIZED	
150		05.04.13	1,000	SCHEIBE B13	WASHER B13 DIN 7349 GALVANIZED	WASHER B13 DIN 7349 GALVANIZED	
160		05.04.17	2,000	SCHEIBE B17	WASHER B17 DIN 7349 GALVANIZED	WASHER B17 DIN 7349 GALVANIZED	
170		12.30.34.25/00	2,000	GLEITBUCHSE	SLIDE BUSHING	DOUILLE DE GLISSEMENT	
180		18.030.042.1	3,000	PASSSCHEIBE 30X42X1 GEOELT	SHIM RING 30X42X1	SHIM RING 30X42X1	
190		24.A.10.100	2,000	SCHMIERNIPPEL M10X1 GERADE, STAHL	LUBRICATING NIPPLE M10X1	LUBRICATING NIPPLE M10X1	
200		55.01.G.153633/00	2,000	DRUCKFEDER 22X51X4,5 EN10270-1 SH	SPRING 22X51X4,5	SPRING 22X51X4,5	
210		01.10.16075	2,000	SKT-SCHRAUBE M16X75 8.8	SKT-BOLT	SKT-BOLT	

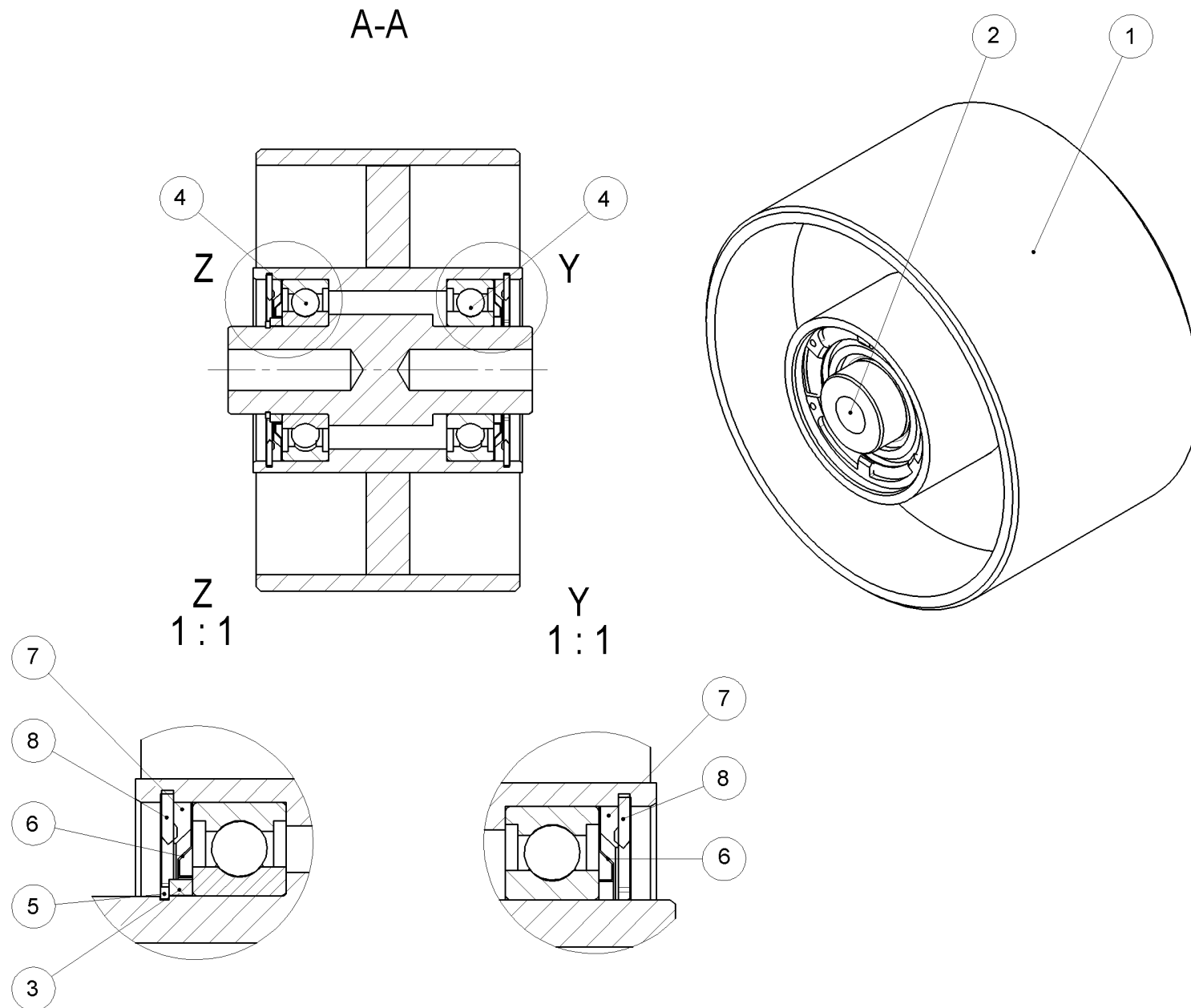



SPANNROLLE - TENSIONING PULLEY
POULIE DE TENSION - 41325311/00

41325311/00

Stücklistennummer / Piece Number / Liste de Pièces / Homep





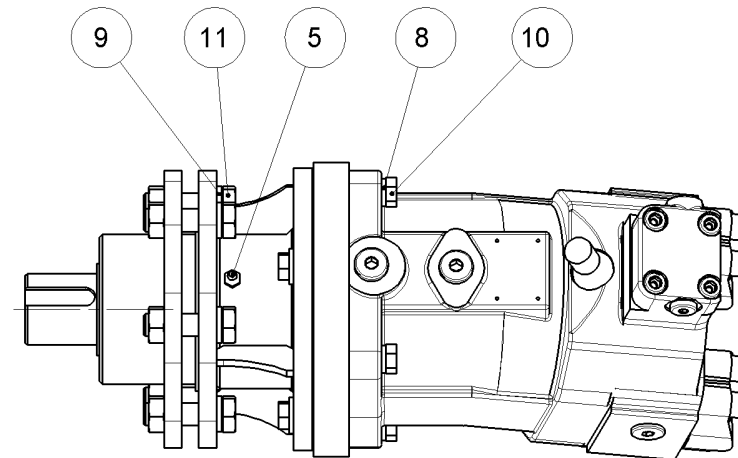
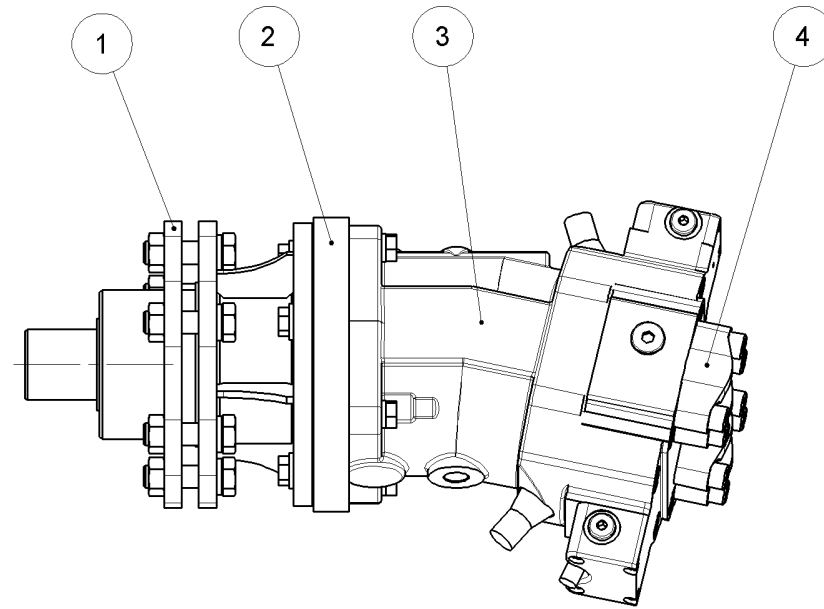







Pos.	Bestell-Nr. Stock Number Numéro de Commande Номер товара	Menge Amount Quantité Количество	Beschreibung	Description	Description	Описание
30	41324423/00	1,000	DISTANZRING	SPACER RING	COURONNE INTERMEDIAIRE	
40	 13.C.0006/00	2,000	RADIALRILLENKUGELLAGER	DEEP GROOVE BALL BEARING	ROULEMENT RIGIDE A BILLES	
50	 16.01.A030	1,000	SICHERUNGSRING A30X1,5	LOCKING RING A30X1,5 DIN471	LOCKING RING A30X1,5 DIN471	
60	28044157/01	2,000	DICHTRING NILOS	NILOS SEALING RING	ANNEAU NILOS	
70	28044429/00	2,000	DISTANZRING NILOS J62	SPACER RING NILOS J62	COURONNE INTERMEDIAIRE NILOS J62	
80	28044430/00	2,000	SICHERUNGSRING-JL62	RETAINING RING-JL62	CIRCLIP-JL62	



HYDR.-MOTOR 80CCM - HYDR.-MOTOR 80CCM
 HYDR.-MOTOR 80CCM - 560.02.00.01.00/A

560.02.00.01.00/A
 Stücklistennummer / Piece Number / Liste de Pièces / Номер





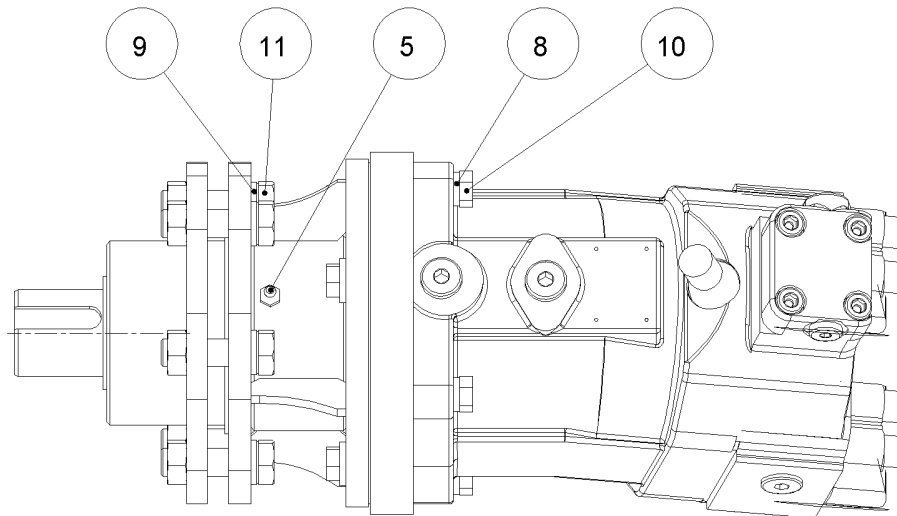
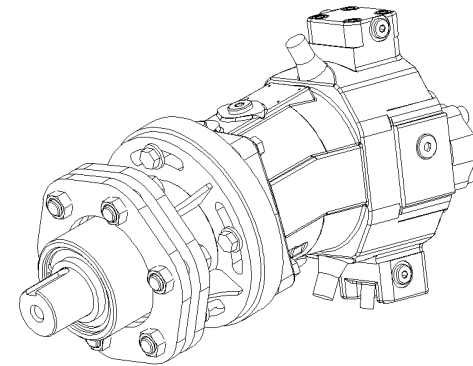
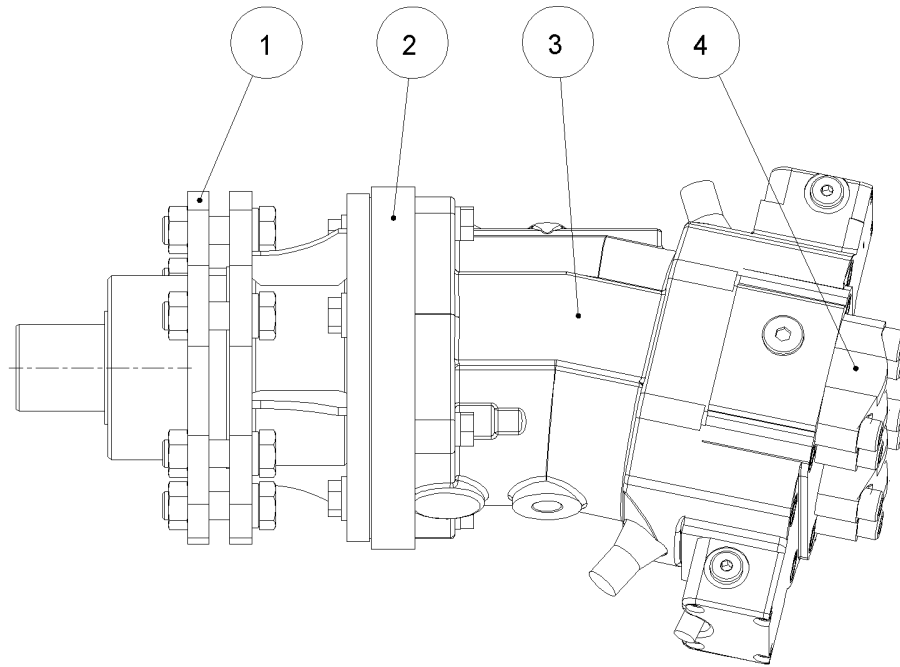







Pos.		Bestell-Nr. Stock Number Numéro de Commande Номер товара	Menge Amount Quantité Количество	Beschreibung	Description	Description	Описание
10		450.02.21.01.00/B	1,000	FLANSCH	FLANSCH	FLANSCH	
20		551.02.05.02.00/A	1,000	<u>LAGERGLOCKE 4-LOCH, LK 180, DIN 5480</u>	BEARING UNIT	BEARING UNIT	
30		20.80.136/00	1,000	<u>AXKO-VERSTELLMOTOR 80CCM</u>	AXIAL PISTON MOTOR 80CC	AXIAL PISTON MOTOR 80CC	
40		20.29.001/00	2,000	SAE-HALBFLANSCH 1 6000 PSI	SAE-HALF FLANGE 1"	SAE-HALF FLANGE 1"	
50		24.A.10.100	1,000	SCHMIERNIPPEL M10X1 GERADE, STAHL	LUBRICATING NIPPLE M10X1	LUBRICATING NIPPLE M10X1	
60		20.02.00559/00	1,000	HYDRAULIKSCHLAUCH	HYDRAULIC HOSE	BOYAU HYDRAULIQUE	
70		20.02.00560/00	1,000	HYDRAULIKSCHLAUCH	HYDRAULIC HOSE	BOYAU HYDRAULIQUE	
80		07.02.12	4,000	NORD-LOCK-SCHEIBE FUER M12	NORD-LOCK-DISC FOR M12	NORD-LOCK-DISC FOR M12	
90		07.02.16	6,000	NORD-LOCK-SCHEIBE FUER M16	NORD-LOCK-DISC FOR M16	NORD-LOCK-DISC FOR M16	
100		01.10.12040	4,000	SKT-SCHRAUBE M12X40 8.8	SCREW M12X40 DIN 933	SCREW M12X40 DIN 933	
110		01.10.16055	6,000	SKT-SCHRAUBE M16X55 8.8	SCREW M16X55 DIN 933	SCREW M16X55 DIN 933	



HYDR.-MOTOR 80CCM - HYDR.-MOTOR 80CCM
 HYDR.-MOTOR 80CCM - 560.02.00.01.00/A

560.02.00.01.00/A
 Stücklistennummer / Piece Number / Liste de Pièces / Номер



Pos.		Bestell-Nr. Stock Number Numéro de Commande Номер товара	Menge Amount Quantité Количество	Beschreibung	Description	Description	Описание
10		450.02.21.01.00/B	1,000	FLANSCH	FLANSCH	FLANSCH	
20		551.02.05.02.00/A	1,000	<u>LAGERGLOCKE 4-LOCH, LK 180, DIN 5480</u>	BEARING UNIT	BEARING UNIT	
30		20.80.136/00	1,000	<u>AXKO-VERSTELLMOTOR 80CCM</u>	AXIAL PISTON MOTOR 80CC	AXIAL PISTON MOTOR 80CC	
40		20.29.001/00	2,000	SAE-HALBFLANSCH 1 6000 PSI	SAE-HALF FLANGE 1"	SAE-HALF FLANGE 1"	
50		24.A.10.100	1,000	SCHMIERNIPPEL M10X1 GERADE, STAHL	LUBRICATING NIPPLE M10X1	LUBRICATING NIPPLE M10X1	
60		20.02.00559/00	1,000	HYDRAULIKSCHLAUCH	HYDRAULIC HOSE	BOYAU HYDRAULIQUE	
70		20.02.00560/00	1,000	HYDRAULIKSCHLAUCH	HYDRAULIC HOSE	BOYAU HYDRAULIQUE	
80		07.02.12	4,000	NORD-LOCK-SCHEIBE FUER M12	NORD-LOCK-DISC FOR M12	NORD-LOCK-DISC FOR M12	
90		07.02.16	6,000	NORD-LOCK-SCHEIBE FUER M16	NORD-LOCK-DISC FOR M16	NORD-LOCK-DISC FOR M16	
100		01.10.12040	4,000	SKT-SCHRAUBE M12X40 8.8	SCREW M12X40 DIN 933	SCREW M12X40 DIN 933	
110		01.10.16055	6,000	SKT-SCHRAUBE M16X55 8.8	SCREW M16X55 DIN 933	SCREW M16X55 DIN 933	

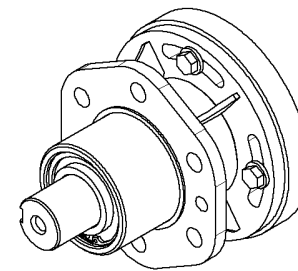
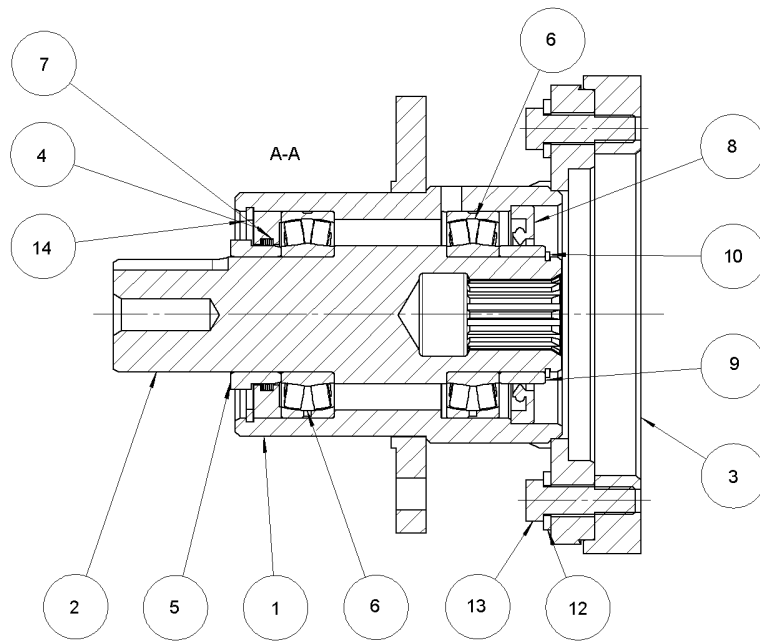
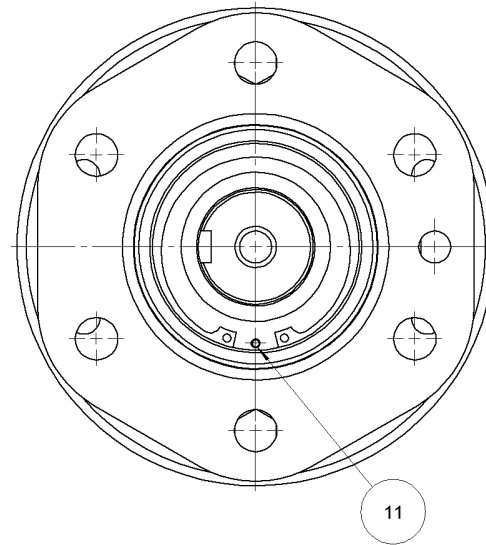
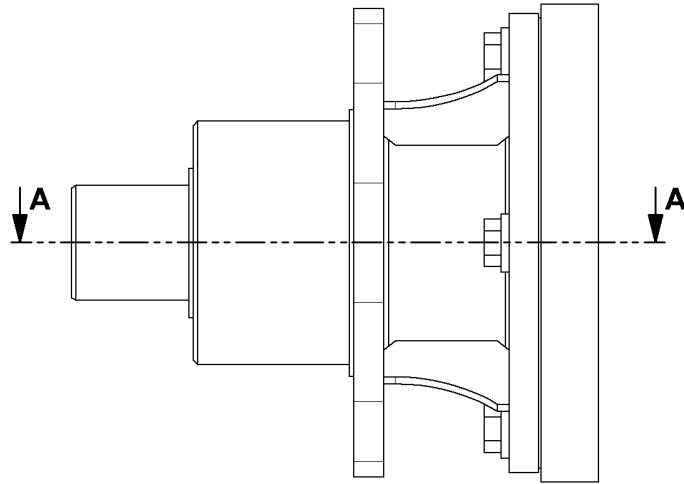

BOM:560.00.00.00.00 MAT: 551.02.05.02.00 DRW/551.02.05.02.00/DE/A 10005427 2020-07-16

LAGERGLOCKE 4-LOCH, LK 180, DIN 5480 - BEARING UNIT
BEARING UNIT - 551.02.05.02.00/A

551.02.05.02.00/A
Stücklistennummer / Piece Number / Liste de Pièces / Номер



Pos.		Bestell-Nr. Stock Number Numéro de Commande Номер товара	Menge Amount Quantité Количество	Beschreibung	Description	Description	Описание
10		551.02.05.22.00/03	1,000	LAGERGLOCKE-GESCHWEISST	BEARING BELL-WELDED	CLOCHE DE PALIER-SOUDE	
20		551.02.05.02.01/A	1,000	VERTEILERWELLE INNENVERZÄHNUNG DIN 5480	SHAFT	SHAFT	
30		740.02.03.00.02/A	1,000	ADAPTERSCHEIBE	ADAPTERSCHEIBE	ADAPTERSCHEIBE	
40		991.05.04.00.01/00	1,000	ABDICHRING	SEALING RING	SEALING RING	
50		991.05.04.00.02/00	1,000	DISTANZRING	DISTANCE RING	DISTANCE RING	
60		13.A.0001/00	2,000	PENDELKUGELLAGER	SELF ALIGNING BALL BEARING	ROULEMENT A ROTULE SUR BILLE	
70		14.05.ISKD060/00	1,000	LAMELLENRING 2,8X1,65 D60	LAMELLA RING	LAMELLA RING	
80		19.02.21.010	1,000	SIMMERRING 60X95X10 BASL, NBR70	SIMMERRING 60X95X10 BASL, NBR70	SIMMERRING 60X95X10 BASL, NBR70	
90		14.0006.02/00	1,000	INNENRING IR50X60X20	INNENRING IR50X60X20	INNENRING IR50X60X20	
100		16.01.A050	1,000	SICHERUNGSRING A50X2,0	RETAINING RING A50 ! CAREFULL!	RETAINING RING A50 ! CAREFULL!	
110		25.01.010.04	1,000	SPANNSTIFT 4X10 STAHL	DOWEL PIN 4X10 DIN 1481	DOWEL PIN 4X10 DIN 1481	

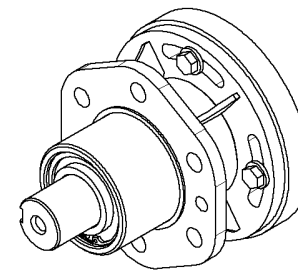
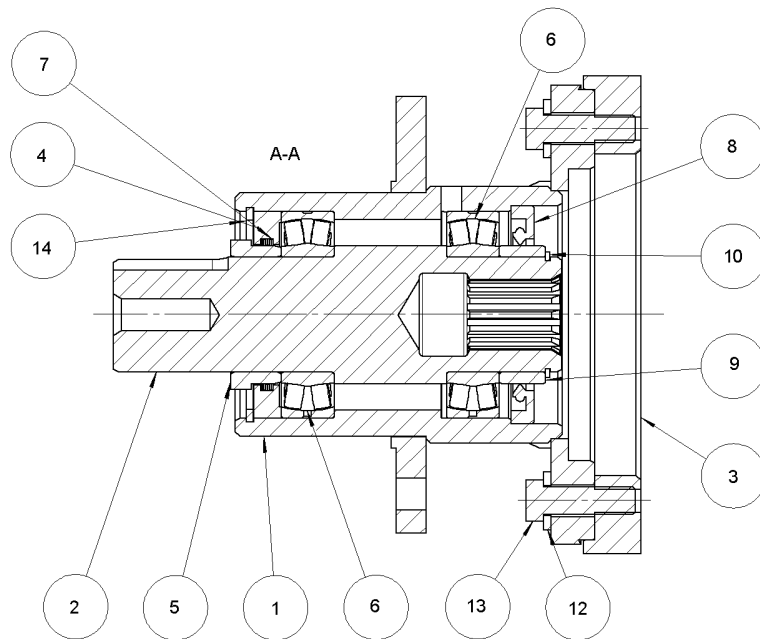
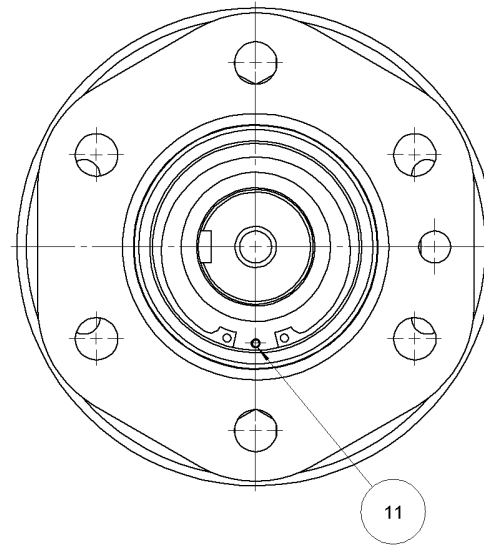
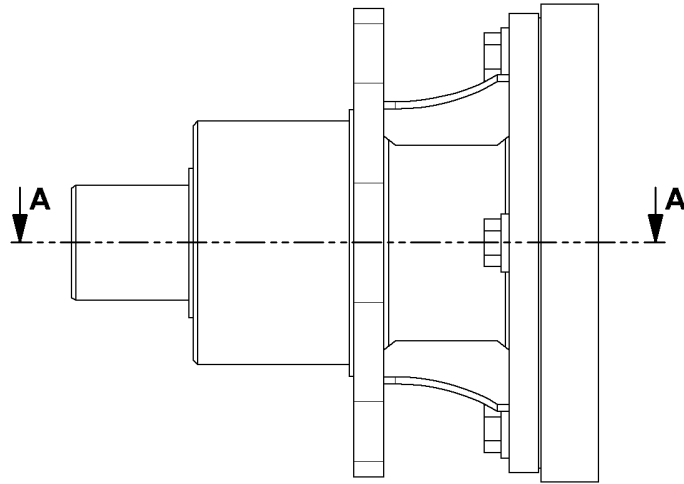



BOM:560.00.00.00.00 MAT: 551.02.05.02.00 DRW/551.02.05.02.00/DE/A 10005427 2020-07-16

LAGERGLOCKE 4-LOCH, LK 180, DIN 5480 - BEARING UNIT
 BEARING UNIT - 551.02.05.02.00/A

551.02.05.02.00/A
 Stücklistennummer / Piece Number / Liste de Pièces / Номер



Pos.	Bestell-Nr. Stock Number Numéro de Commande Номер товара	Menge Amount Quantité Количество	Beschreibung	Description	Description	Описание
120	 07.03.12	4,000	NORD-LOCK-SCHEIBE FUER M12	NORD-LOCK WASHER M12	NORD-LOCK WASHER M12	
130	 01.10.12040	4,000	SKT-SCHRAUBE M12X40 8.8	SCREW M12X40 DIN 933	SCREW M12X40 DIN 933	
140	 16.01.J090	1,000	SICHERUNGSRING J90X3,0	RETAINING RING J90 ! CAREFULL!!	RETAINING RING J90 ! CAREFULL!!	

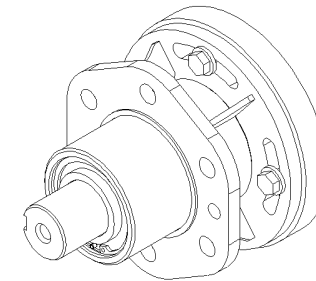
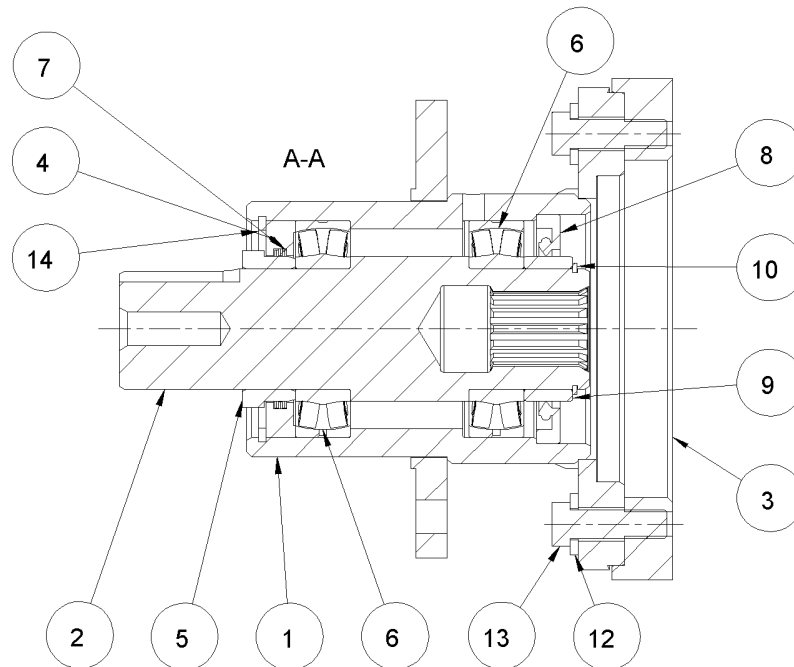
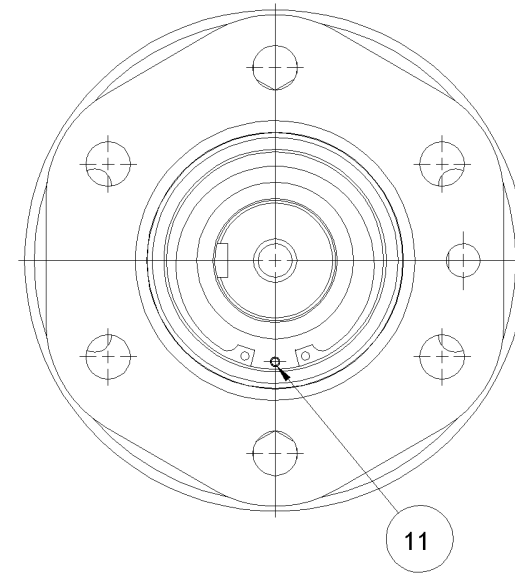
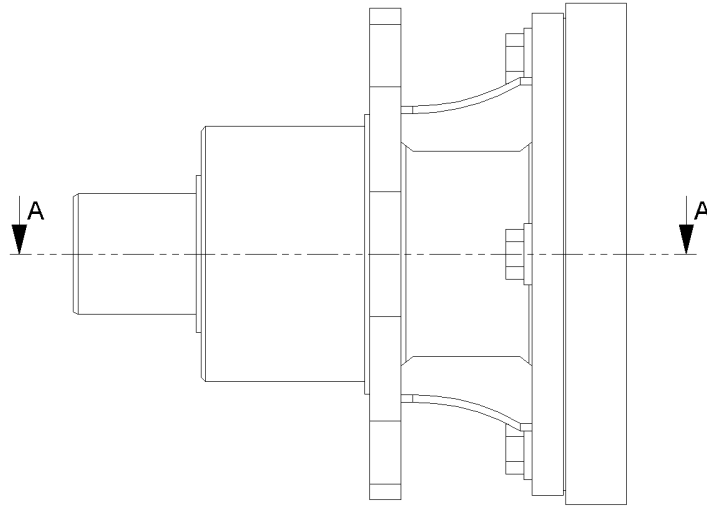

LAGERGLOCKE 4-LOCH, LK 180, DIN 5480 - BEARING UNIT
BEARING UNIT - 551.02.05.02.00/A

551.02.05.02.00/A
Stücklistennummer / Piece Number / Liste de Pièces / Номер



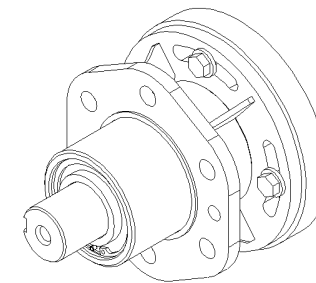
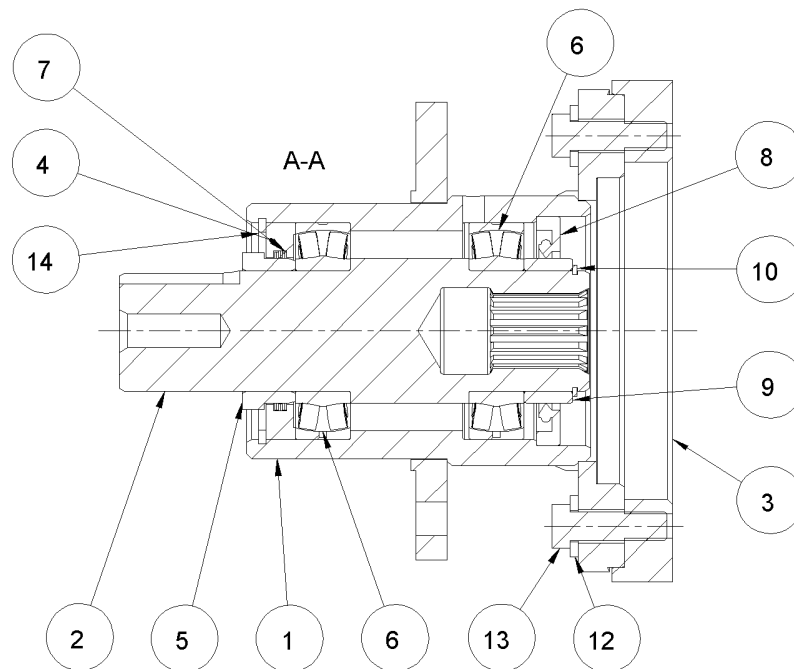
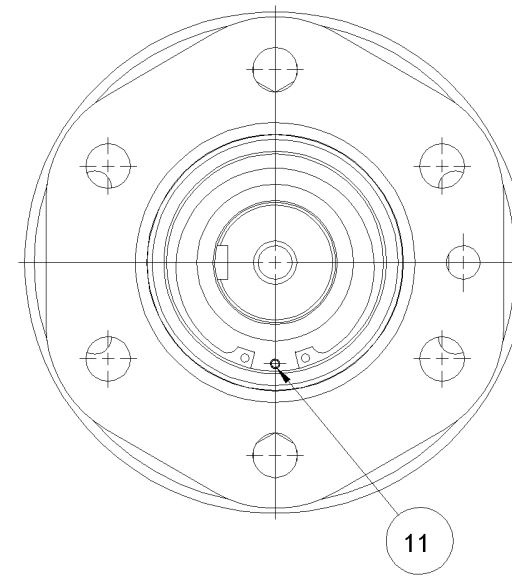
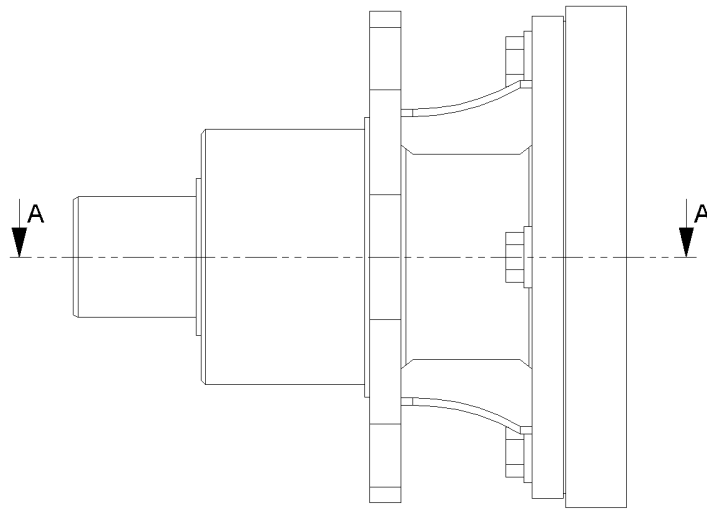

Pos.		Bestell-Nr. Stock Number Numéro de Commande Номер товара	Menge Amount Quantité Количество	Beschreibung	Description	Description	Описание
10		551.02.05.22.00/03	1,000	LAGERGLOCKE-GESCHWEISST	BEARING BELL-WELDED	CLOCHE DE PALIER-SOUDE	
20		551.02.05.02.01/A	1,000	VERTEILERWELLE INNENVERZÄHNUNG DIN 5480	SHAFT	SHAFT	
30		740.02.03.00.02/A	1,000	ADAPTERSCHEIBE	ADAPTERSCHEIBE	ADAPTERSCHEIBE	
40		991.05.04.00.01/00	1,000	ABDICHRING	SEALING RING	SEALING RING	
50		991.05.04.00.02/00	1,000	DISTANZRING	DISTANCE RING	DISTANCE RING	
60		13.A.0001/00	2,000	PENDELKUGELLAGER	SELF ALIGNING BALL BEARING	ROULEMENT A ROTULE SUR BILLE	
70		14.05.ISKD060/00	1,000	LAMELLENRING 2,8X1,65 D60	LAMELLA RING	LAMELLA RING	
80		19.02.21.010	1,000	SIMMERRING 60X95X10 BASL, NBR70	SIMMERRING 60X95X10 BASL, NBR70	SIMMERRING 60X95X10 BASL, NBR70	
90		14.0006.02/00	1,000	INNENRING IR50X60X20	INNENRING IR50X60X20	INNENRING IR50X60X20	
100		16.01.A050	1,000	SICHERUNGSRING A50X2,0	RETAINING RING A50 ! CAREFULL!	RETAINING RING A50 ! CAREFULL!	
110		25.01.010.04	1,000	SPANNSTIFT 4X10 STAHL	DOWEL PIN 4X10 DIN 1481	DOWEL PIN 4X10 DIN 1481	



LAGERGLOCKE 4-LOCH, LK 180, DIN 5480 - BEARING UNIT
 BEARING UNIT - 551.02.05.02.00/A

551.02.05.02.00/A
 Stücklistennummer / Piece Number / Liste de Pièces / Номер



Pos.	Bestell-Nr. Stock Number Numéro de Commande Номер товара	Menge Amount Quantité Количество	Beschreibung	Description	Description	Описание
120	 07.03.12	4,000	NORD-LOCK-SCHEIBE FUER M12	NORD-LOCK WASHER M12	NORD-LOCK WASHER M12	
130	 01.10.12040	4,000	SKT-SCHRAUBE M12X40 8.8	SCREW M12X40 DIN 933	SCREW M12X40 DIN 933	
140	 16.01.J090	1,000	SICHERUNGSRING J90X3,0	RETAINING RING J90 ! CAREFULL!!	RETAINING RING J90 ! CAREFULL!!	

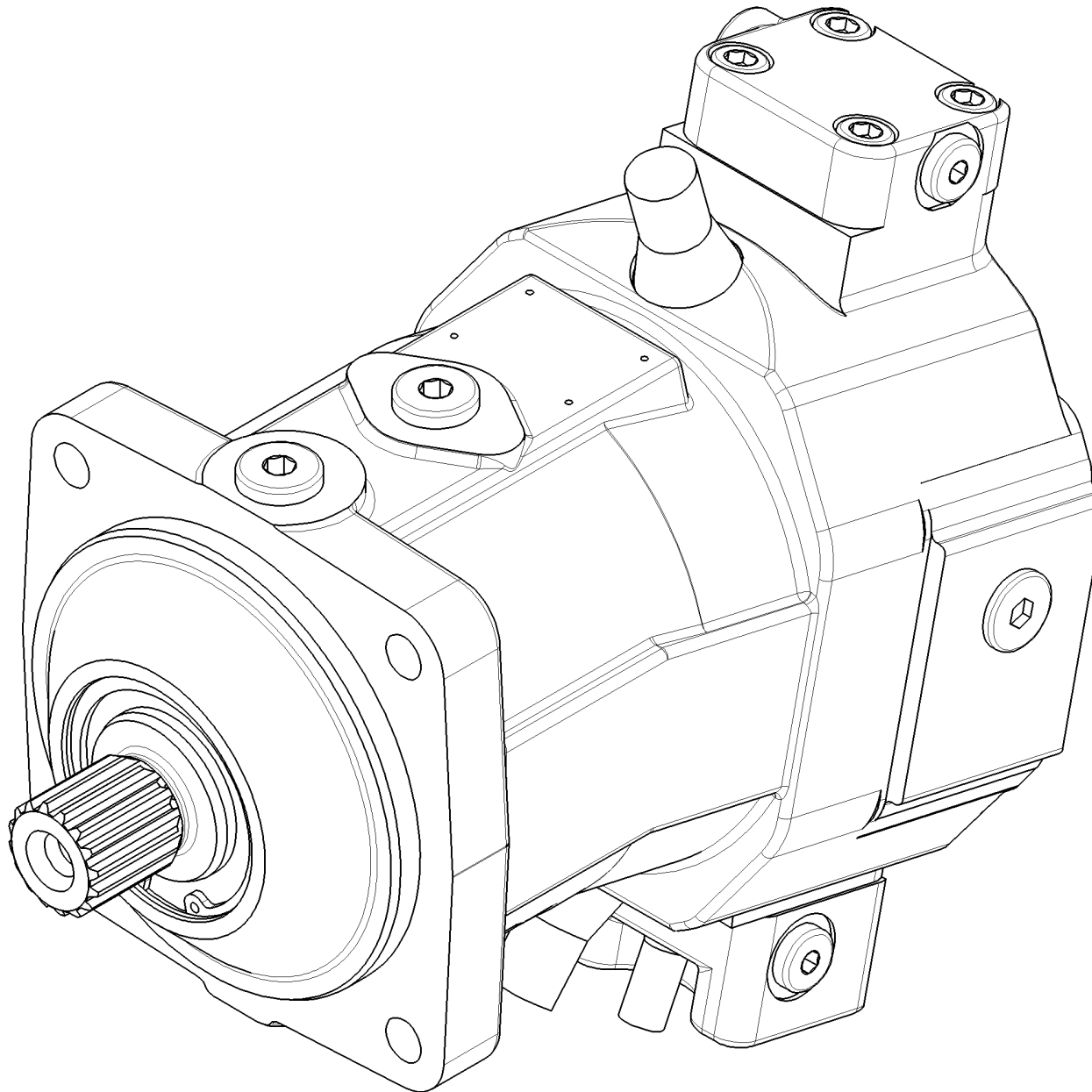

AXKO-VERSTELLMOTOR 80CCM - AXIAL PISTON MOTOR 80CC
AXIAL PISTON MOTOR 80CC - 20.80.136/00

20.80.136/00

Stücklistennummer / Piece Number / Liste de Pièces / Номер



Pos.	Bestell-Nr. Stock Number Numéro de Commande Номер товара	Menge Amount Quantité Количество	Beschreibung	Description	Description	Описание
------	---	---	--------------	-------------	-------------	----------



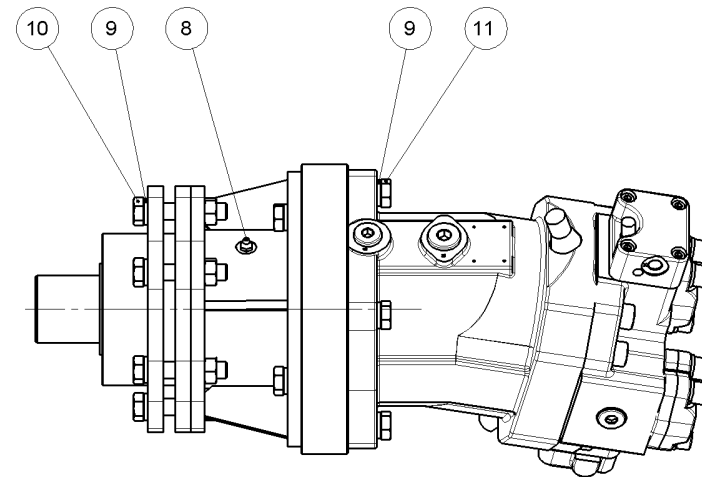
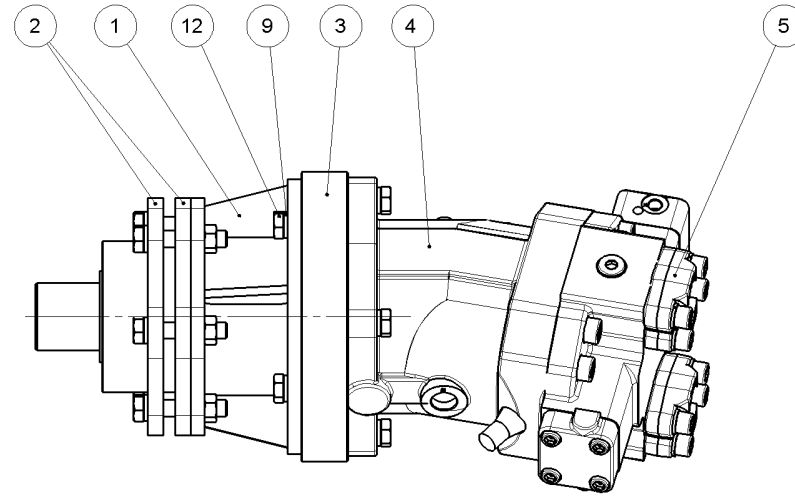







10	20.80.030.03	1,000	WELLENDICHTRING 50X72X7,5	ROTARY SHAFT SEAL	ROTARY SHAFT SEAL	
----	--------------	-------	---------------------------	-------------------	-------------------	--



HYDR.-MOTOR 160CCM - HYDR.-MOTOR 160CCM
 HYDR.-MOTOR 160CCM - 560.02.00.02.00/A

560.02.00.02.00/A
 Stücklistennummer / Piece Number / Liste de Pièces / Номер



Pos.		Bestell-Nr. Stock Number Numéro de Commande Номер товара	Menge Amount Quantité Количество	Beschreibung	Description	Description	Описание
10		650.02.03.03.00/A	1,000	LAGERGLOCKE	BEARING HOUSING	BEARING HOUSING	
20		652.02.00.01.02/A	2,000	FLANSCHPLATTE	FLANGE	FLANGE	
30		650.02.00.03.01/00	1,000	ADAPTERRING	ADAPTERRING	ADAPTERRING	
40		20.80.144/00	1,000	AXKO-VERSTELLMOTOR 160CCM	AXIAL PISTON MOTOR 160CCM	AXIAL PISTON MOTOR 160CCM	
50		20.29.005/A	2,000	SAE-HALBFLANSCH 1 1/4 6000 PSI	SAE-HALBFLANSCH 1 1/4 6000 PSI	SAE-HALBFLANSCH 1 1/4 6000 PSI	
60		20.02.00528/00	1,000	HYDRAULIKSCHLAUCH	HYDRAULIC HOSE	BOYAU HYDRAULIQUE	
70		20.02.00562/00	1,000	HYDRAULIKSCHLAUCH	HYDRAULIC HOSE	BOYAU HYDRAULIQUE	
80		24.A.10.100	1,000	SCHMIERNIPPEL M10X1 GERADE, STAHL	LUBRICATING NIPPLE M10X1	LUBRICATING NIPPLE M10X1	
90		07.02.16	14,0- 00	NORD-LOCK-SCHEIBE FUER M16	NORD-LOCK-DISC FOR M16	NORD-LOCK-DISC FOR M16	
100		01.10.16080	6,000	SKT-SCHRAUBE M16X80 8.8	SCREW M16X80 DIN933	SCREW M16X80 DIN933	
110		01.10.16065	4,000	SKT-SCHRAUBE M16X65 8.8	HEX. SCREW M16X65 DIN933	HEX. SCREW M16X65 DIN933	

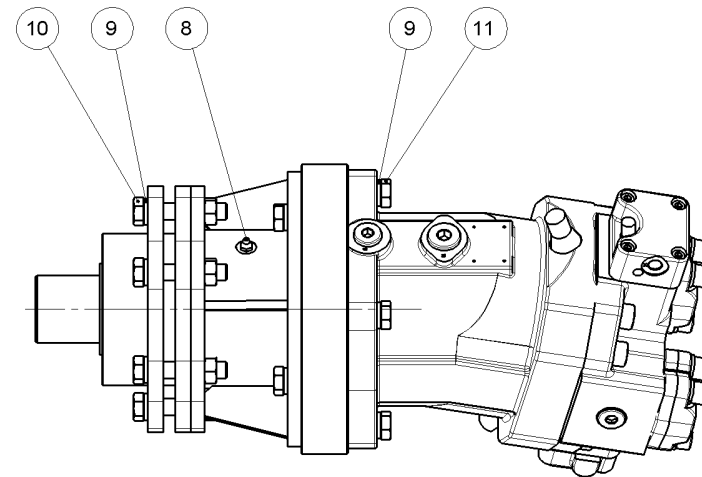
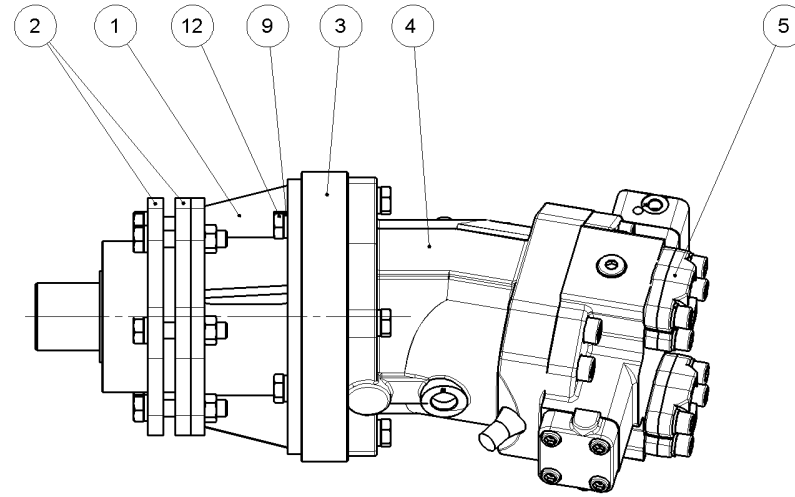

HYDR.-MOTOR 160CCM - HYDR.-MOTOR 160CCM
HYDR.-MOTOR 160CCM - 560.02.00.02.00/A

560.02.00.02.00/A
Stücklistennummer / Piece Number / Liste de Pièces / Номер





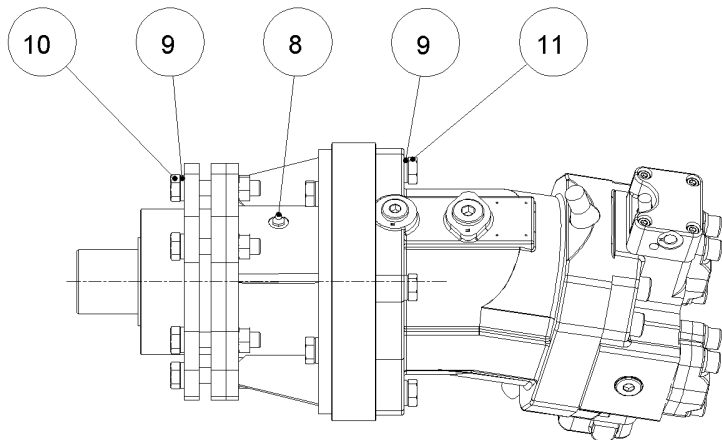
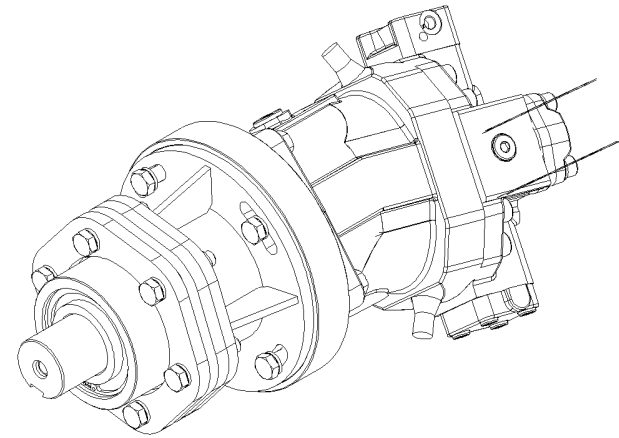
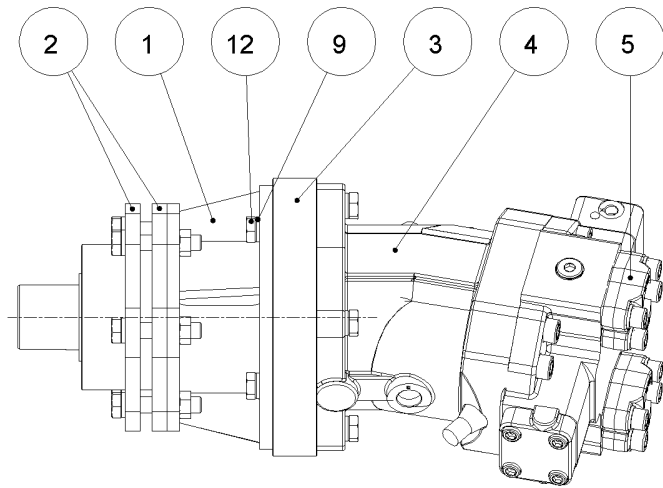







Pos.	Bestell-Nr. Stock Number Numéro de Commande Номер товара	Menge Amount Quantité Количество	Beschreibung	Description	Description	Описание
120	 01.10.16050	4,000	SKT-SCHRAUBE M16X50 8.8	HEX. SCREW M16X50 DIN933	HEX. SCREW M16X50 DIN933	



HYDR.-MOTOR 160CCM - HYDR.-MOTOR 160CCM
 HYDR.-MOTOR 160CCM - 560.02.00.02.00/A

560.02.00.02.00/A
 Stücklistennummer / Piece Number / Liste de Pièces / Номер



Pos.		Bestell-Nr. Stock Number Numéro de Commande Номер товара	Menge Amount Quantité Количество	Beschreibung	Description	Description	Описание
10		650.02.03.03.00/A	1,000	LAGERGLOCKE	BEARING HOUSING	BEARING HOUSING	
20		652.02.00.01.02/A	2,000	FLANSCHPLATTE	FLANGE	FLANGE	
30		650.02.00.03.01/00	1,000	ADAPTERRING	ADAPTERRING	ADAPTERRING	
40		20.80.144/00	1,000	AXKO-VERSTELLMOTOR 160CCM	AXIAL PISTON MOTOR 160CCM	AXIAL PISTON MOTOR 160CCM	
50		20.29.005/A	2,000	SAE-HALBFLANSCH 1 1/4 6000 PSI	SAE-HALBFLANSCH 1 1/4 6000 PSI	SAE-HALBFLANSCH 1 1/4 6000 PSI	
60		20.02.00528/00	1,000	HYDRAULIKSCHLAUCH	HYDRAULIC HOSE	BOYAU HYDRAULIQUE	
70		20.02.00562/00	1,000	HYDRAULIKSCHLAUCH	HYDRAULIC HOSE	BOYAU HYDRAULIQUE	
80		24.A.10.100	1,000	SCHMIERNIPPEL M10X1 GERADE, STAHL	LUBRICATING NIPPLE M10X1	LUBRICATING NIPPLE M10X1	
90		07.02.16	14,0- 00	NORD-LOCK-SCHEIBE FUER M16	NORD-LOCK-DISC FOR M16	NORD-LOCK-DISC FOR M16	
100		01.10.16080	6,000	SKT-SCHRAUBE M16X80 8.8	SCREW M16X80 DIN933	SCREW M16X80 DIN933	
110		01.10.16065	4,000	SKT-SCHRAUBE M16X65 8.8	HEX. SCREW M16X65 DIN933	HEX. SCREW M16X65 DIN933	

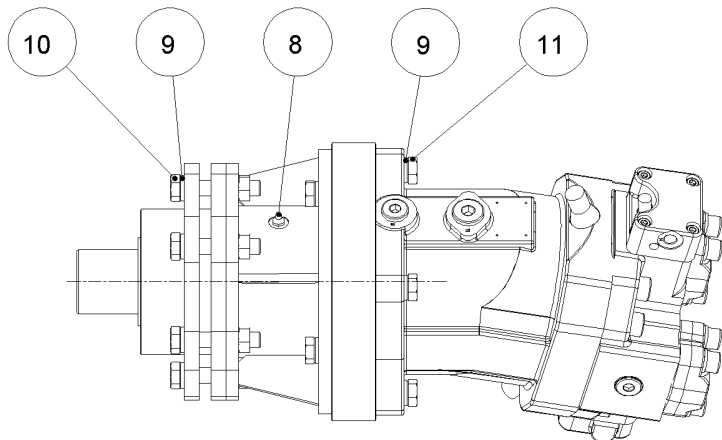
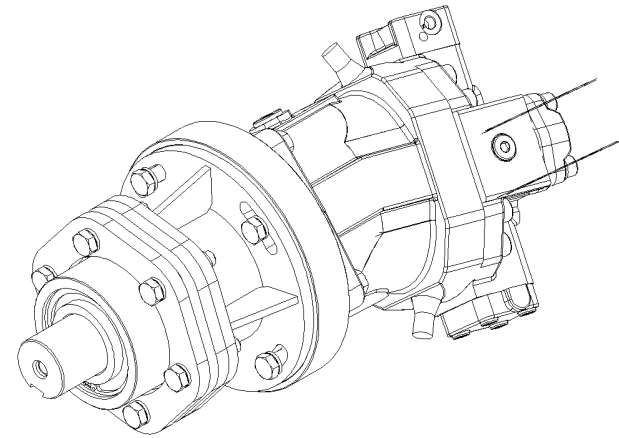
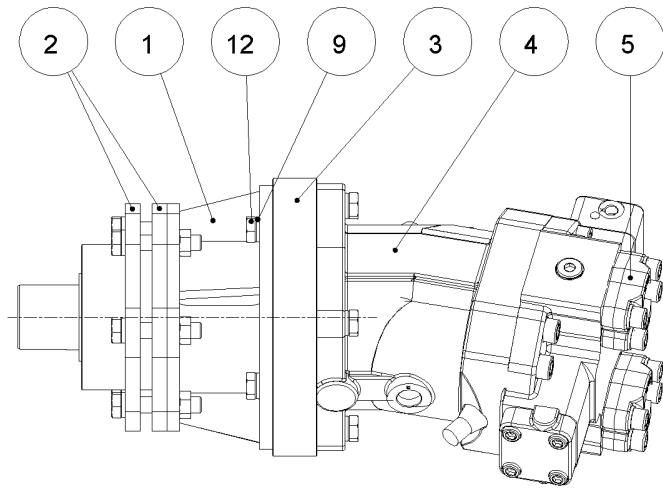

HYDR.-MOTOR 160CCM - HYDR.-MOTOR 160CCM
HYDR.-MOTOR 160CCM - 560.02.00.02.00/A

560.02.00.02.00/A
Stücklistennummer / Piece Number / Liste de Pièces / Номер



Pos.	Bestell-Nr. Stock Number Numéro de Commande Номер товара	Menge Amount Quantité Количество	Beschreibung	Description	Description	Описание
120	 01.10.16050	4,000	SKT-SCHRAUBE M16X50 8.8	HEX. SCREW M16X50 DIN933	HEX. SCREW M16X50 DIN933	

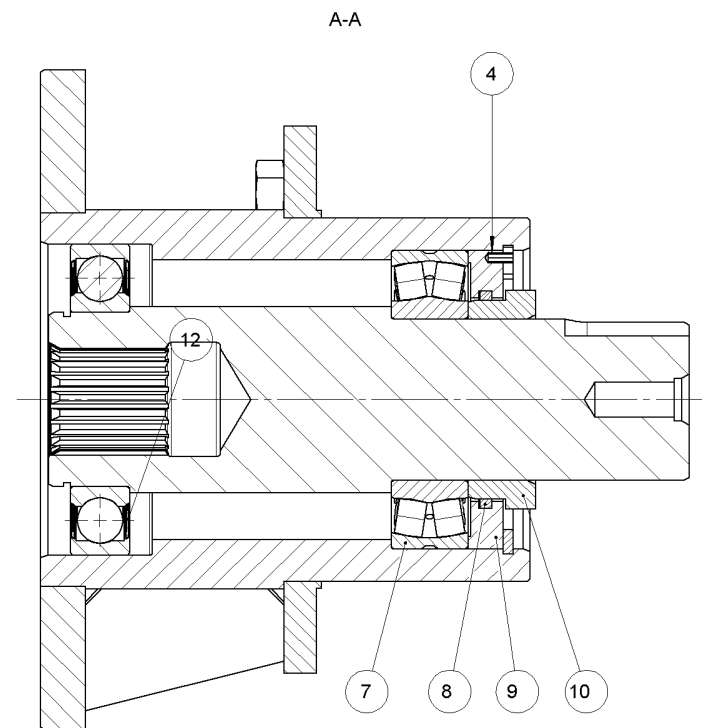
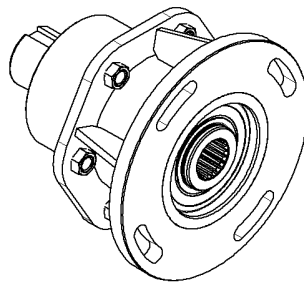
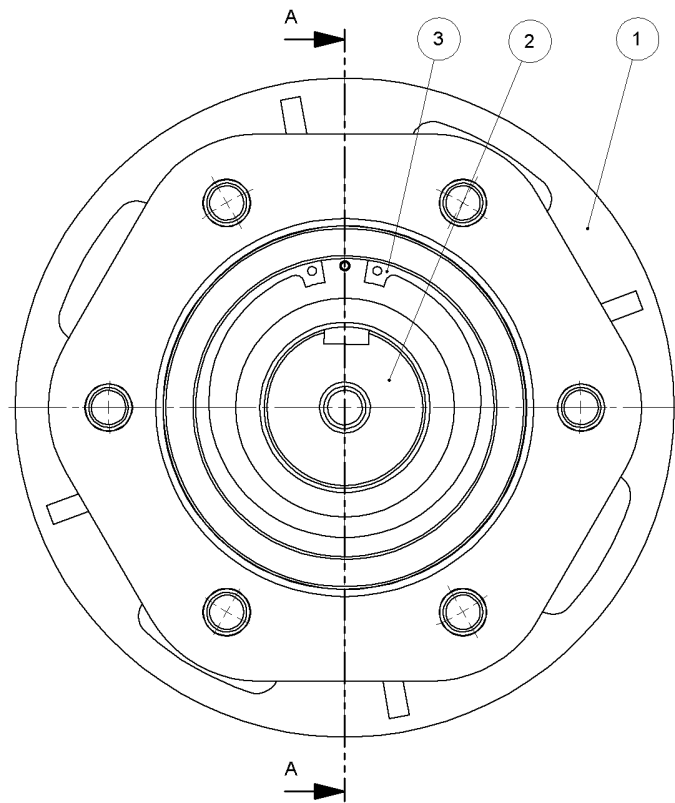

LAGERGLOCKE - BEARING HOUSING
BEARING HOUSING - 650.02.03.03.00/A

650.02.03.03.00/A
Stücklistennummer / Piece Number / Liste de Pièces / Номер



Pos.		Bestell-Nr. Stock Number Numéro de Commande Номер товара	Menge Amount Quantité Количество	Beschreibung	Description	Description	Описание
10		650.02.02.02.00/01	1,000	LAGERGLOCKE-GESCHWEISST	BEARING BELL-WELDED	CLOCHE DE PALIER-SOUDE	
20		650.02.03.03.01/01	1,000	WELLE-INNENVERZAHNT	SHAFT-INTERNAL GEAR TEETH	ARBRE-A DENTURE INTERIEURE	
30		61.1.03/00	1,000	SCHMIERFETT	SCHMIERFETT	SCHMIERFETT	
40		16.01.J120	1,000	SICHERUNGSRING J120X4,0	LOCKING RING J120X4,0 DIN472	LOCKING RING J120X4,0 DIN472	
50		25.01.010.04	1,000	SPANNSTIFT 4X10 STAHL	DOWEL PIN 4X10 DIN 1481	DOWEL PIN 4X10 DIN 1481	
60		13.C.0096/00	1,000	RADIALRILLENKUGELLAGER	DEEP GROOVE BALL BEARING	ROULEMENT RIGIDE A BILLES	
70		16.01.A070	1,000	SICHERUNGSRING A70X2.5	SICHERUNGSRING A70X2.5	SICHERUNGSRING A70X2.5	
80		13.A.0002/00	1,000	PENDELKUGELLAGER	SELF ALIGNING BALL BEARING	ROULEMENT A ROTULE SUR BILLE	
90		14.05.ISKD080/00	1,000	LAMELLENRING 3,5X1,65 D80	LAMELLA RING	LAMELLA RING	
100		750.25.1.01/A	1,000	ABDICHRING 120X81, T=14	SEALING RING 120X81 T=14	SEALING RING 120X81 T=14	
110		013.03.0.01/00	1,000	DISTANZRING D88X65X27	SPACER RING	SPACER RING	

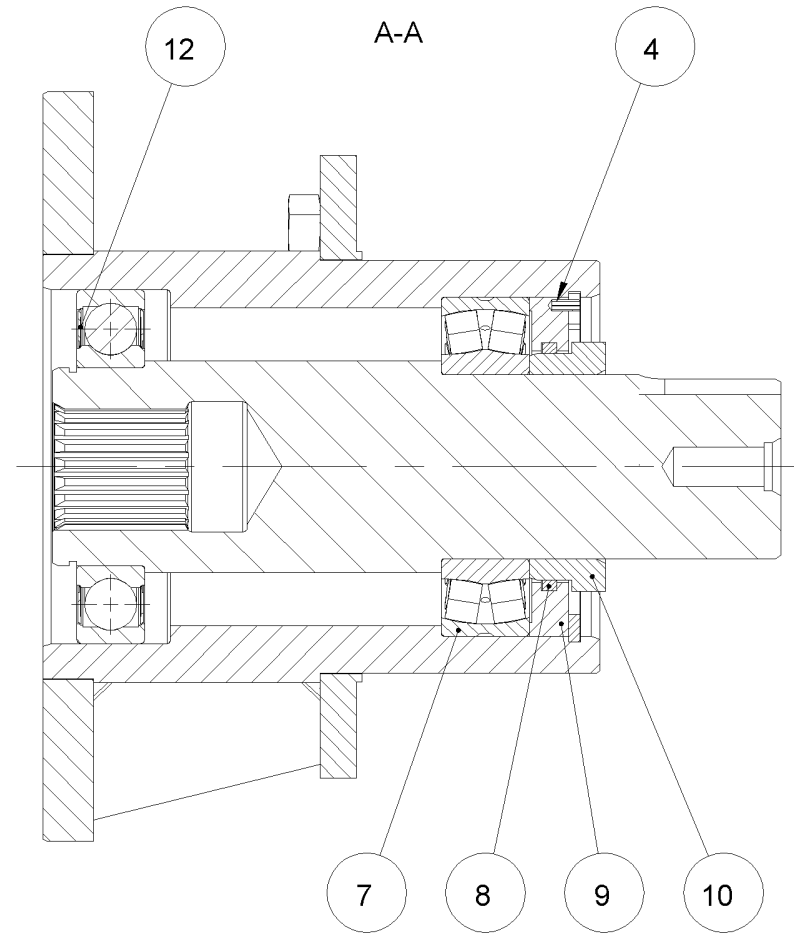
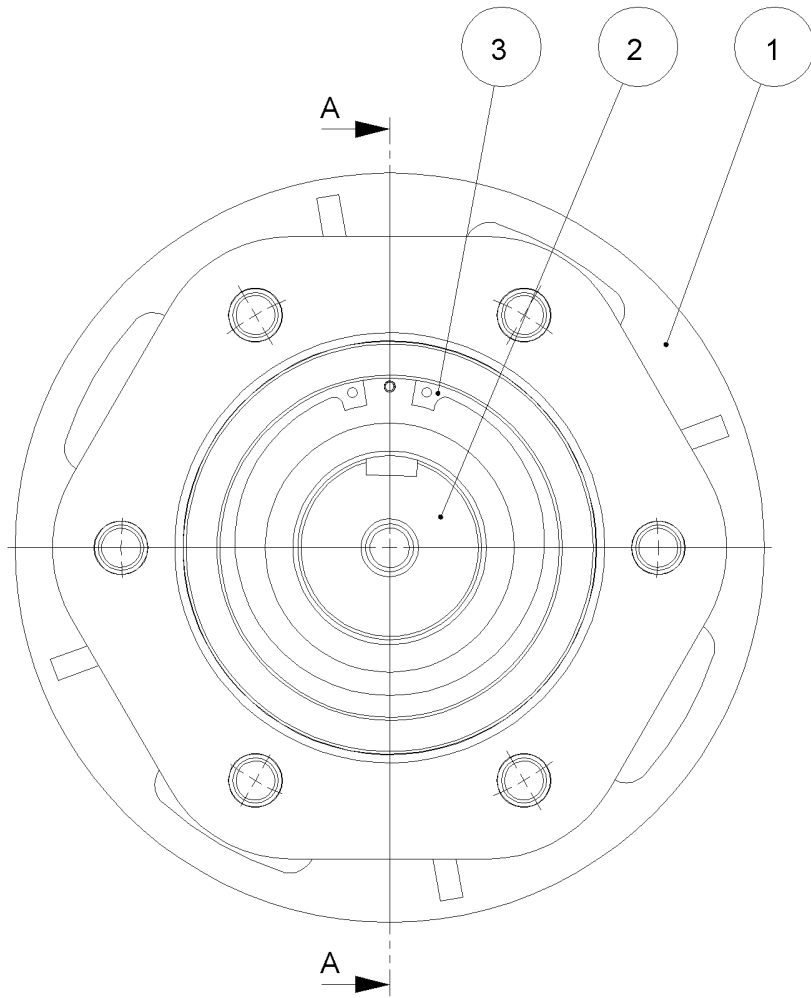

LAGERGLOCKE - BEARING HOUSING
BEARING HOUSING - 650.02.03.03.00/A

650.02.03.03.00/A
Stücklistennummer / Piece Number / Liste de Pièces / Номер



Pos.		Bestell-Nr. Stock Number Numéro de Commande Номер товара	Menge Amount Quantité Количество	Beschreibung	Description	Description	Описание
10		650.02.02.02.00/01	1,000	LAGERGLOCKE-GESCHWEISST	BEARING BELL-WELDED	CLOCHE DE PALIER-SOUDE	
20		650.02.03.03.01/01	1,000	WELLE-INNENVERZAHNT	SHAFT-INTERNAL GEAR TEETH	ARBRE-A DENTURE INTERIEURE	
30		61.1.03/00	1,000	SCHMIERFETT	SCHMIERFETT	SCHMIERFETT	
40		16.01.J120	1,000	SICHERUNGSRING J120X4,0	LOCKING RING J120X4,0 DIN472	LOCKING RING J120X4,0 DIN472	
50		25.01.010.04	1,000	SPANNSTIFT 4X10 STAHL	DOWEL PIN 4X10 DIN 1481	DOWEL PIN 4X10 DIN 1481	
60		13.C.0096/00	1,000	RADIALRILLENKUGELLAGER	DEEP GROOVE BALL BEARING	ROULEMENT RIGIDE A BILLES	
70		16.01.A070	1,000	SICHERUNGSRING A70X2.5	SICHERUNGSRING A70X2.5	SICHERUNGSRING A70X2.5	
80		13.A.0002/00	1,000	PENDELKUGELLAGER	SELF ALIGNING BALL BEARING	ROULEMENT A ROTULE SUR BILLE	
90		14.05.ISKD080/00	1,000	LAMELLENRING 3,5X1,65 D80	LAMELLA RING	LAMELLA RING	
100		750.25.1.01/A	1,000	ABDICHRING 120X81, T=14	SEALING RING 120X81 T=14	SEALING RING 120X81 T=14	
110		013.03.0.01/00	1,000	DISTANZRING D88X65X27	SPACER RING	SPACER RING	

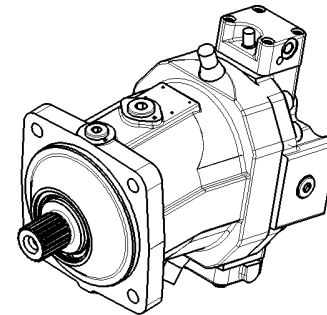

AXKO-VERSTELLMOTOR 160CCM - AXIAL PISTON MOTOR 160CCM
AXIAL PISTON MOTOR 160CCM - 20.80.144/00

20.80.144/00

Stücklistennummer / Piece Number / Liste de Pièces / Номер



Pos.	Bestell-Nr. Stock Number Numéro de Commande Номер товара	Menge Amount Quantité Количество	Beschreibung	Description	Description	Описание
10	 20.80.134.02	1,000	WELLENDICHTRING 70X90X7 / 5,5	ROTARY SHAFT SEAL	ROTARY SHAFT SEAL	

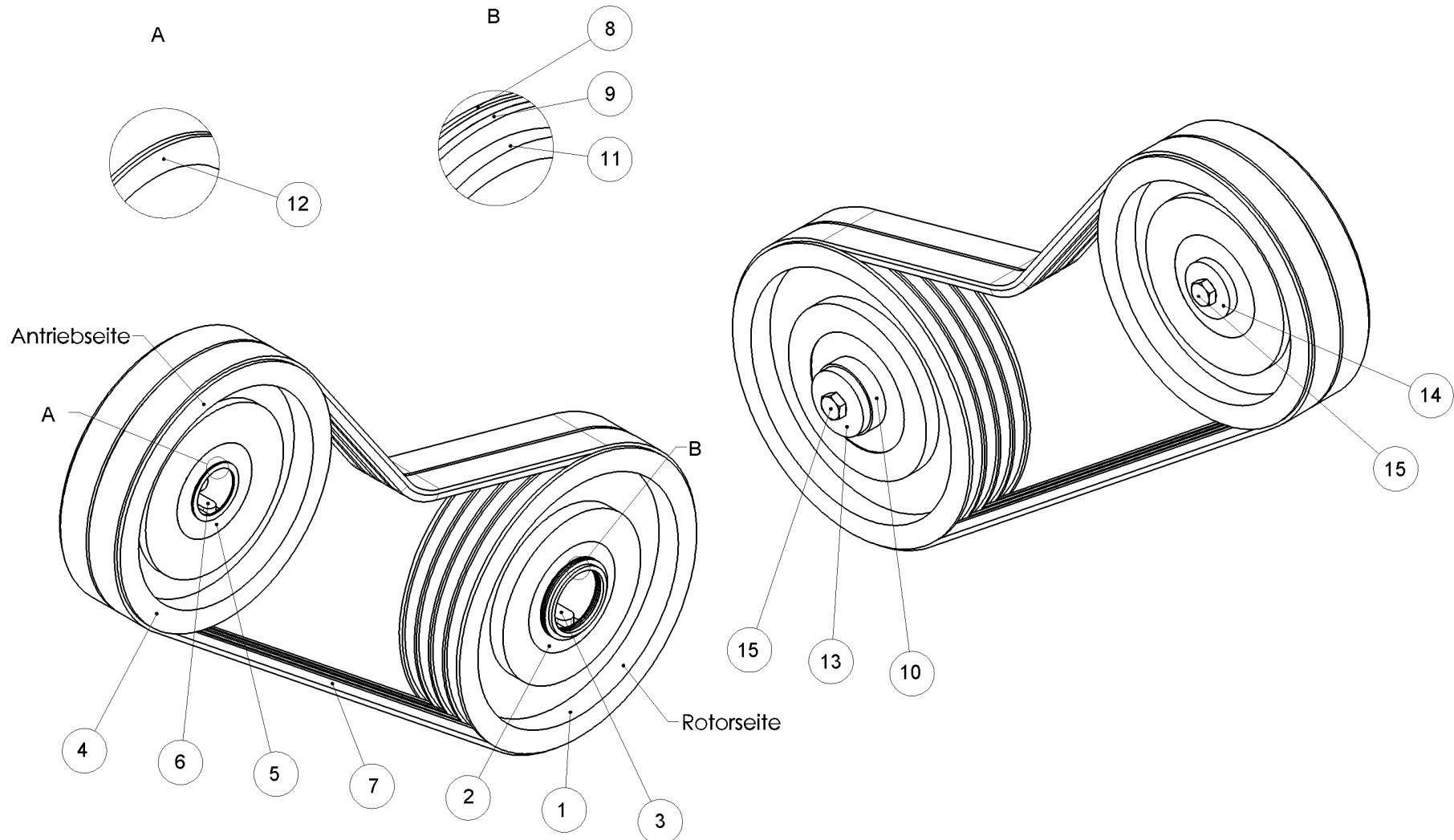

RIEMENUEBERSETZUNG I 1,13 - BELT RATIO I=1,13 - 80CCM
 BELT RATIO I=1,13 - 80CCM - 560.02.04.03.00/00

560.02.04.03.00/00
 Stücklistennummer / Piece Number / Liste de Pièces / Homep



Pos.		Bestell-Nr. Stock Number Numéro de Commande Номер товара	Menge Amount Quantité Количество	Beschreibung	Description	Description	Описание
10		48.01.315.4/00	1,000	KEILRIEMENSCHLEIBE SPB 315X4 TL 3525 KM	V-BELT PULLEY 315X4	V-BELT PULLEY 315X4	
20		49.65.3525/00	1,000	<u>TAPERLOCK 3525 D65</u>	TAPERLOCK-BUSHING D 65 /3525	TAPERLOCK-BUSHING D 65 /3525	
30		09.18.11.63	1,000	PASSFEDER 18X11X63 FORM A	FEATHER KEY 18X11X63 DIN6885	FEATHER KEY 18X11X63 DIN6885	
40		48.01.280.4/00	1,000	KEILRIEMENSCHLEIBE SPB 280X4 TL 3020 KM	V-BELT PULLEY 280X4	V-BELT PULLEY 280X4	
50		49.50.3020/00	1,000	<u>TAPERLOCK 3020 D50</u>	TAPERLOCK-BUSHING D 50 /3020	TAPERLOCK-BUSHING D 50 /3020	
60		09.14.09.50	1,000	PASSFEDER 14X9X50 FORM A	SPRING 14 X 9 X 50 DIN6885	SPRING 14 X 9 X 50 DIN6885	
70		50.2.2187.B.Z.2	2,000	POWERBAND 2 HB 2187 LA AUSFUEHRUNG 7726	POWERBELT 2 HB 2187 LA	POWERBELT 2 HB 2187 LA	
80		18.065.085.1	2,000	PASSSCHEIBE 65X85X1 GEOELT	SPACER / WASHER 65X85X1	SPACER / WASHER 65X85X1	
90		18.065.085.2	2,000	PASSSCHEIBE 65X85X2 GEOELT	ADJUSTING WASHER 65X85X2	ADJUSTING WASHER 65X85X2	
100		796.6.2.66/B	1,000	<u>DISTANZRING D75X4.5X18</u>	DISTANCE RING	DISTANCE RING	
110		754.20.5.02/A	1,000	<u>DISTANZRING D75X4.5X4</u>	DISTANCE RING	DISTANCE RING	

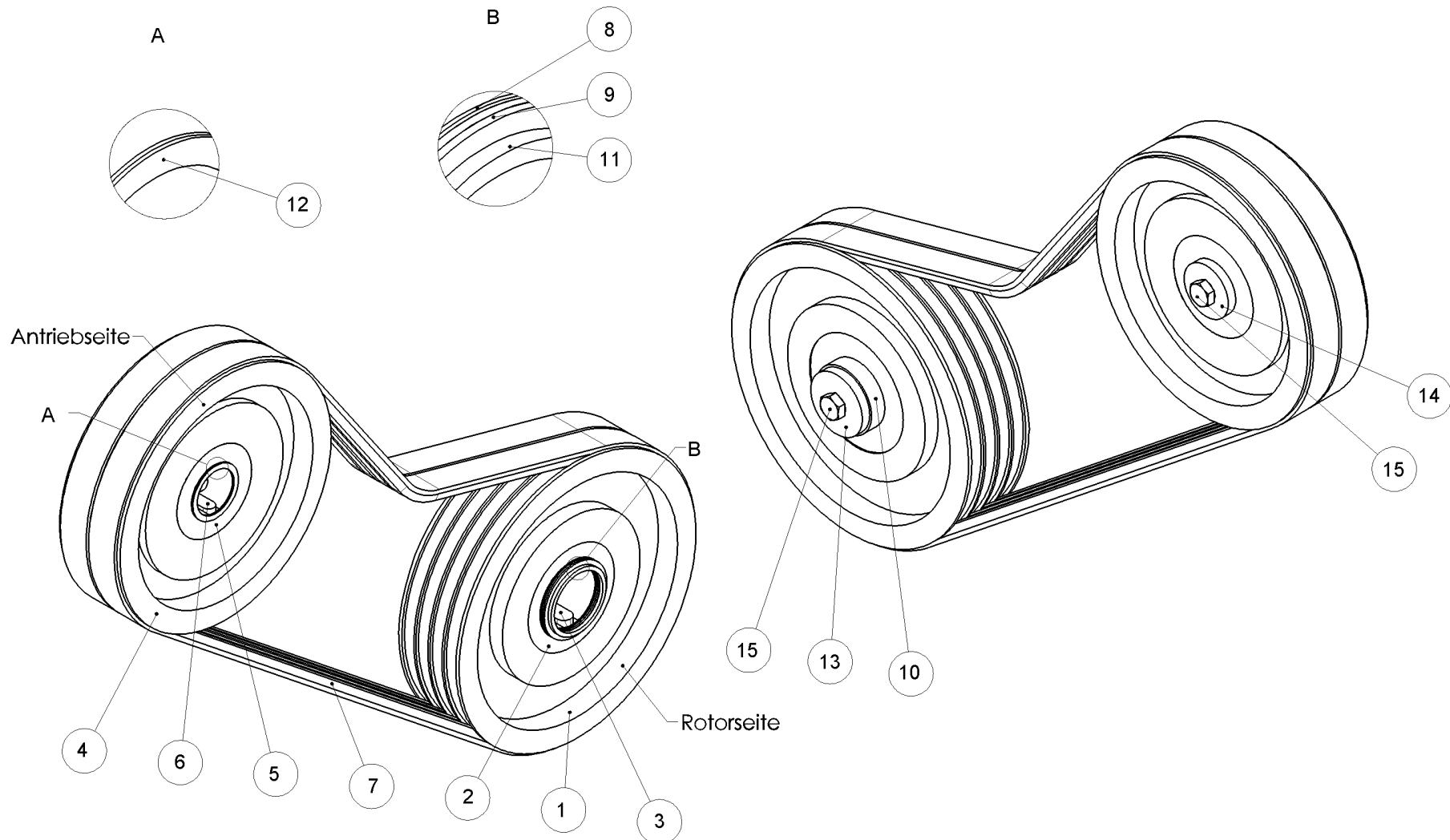

RIEMENUEBERSETZUNG I 1,13 - BELT RATIO I=1,13 - 80CCM
 BELT RATIO I=1,13 - 80CCM - 560.02.04.03.00/00

560.02.04.03.00/00
 Stücklistennummer / Piece Number / Liste de Pièces / Номер



Pos.		Bestell-Nr. Stock Number Numéro de Commande Номер товара	Menge Amount Quantité Количество	Beschreibung	Description	Description	Описание
120		18.050.062.1	2,000	PASSSCHEIBE 50X62X1 GEOELT	SPACER	SPACER	
130		05.10.070.17.5.J	1,000	SCHEIBE 70XD17,5X10	DISC 70X17,5X10	DISC 70X17,5X10	
140		05.10.060.17.0.J	1,000	SCHEIBE 60XD17X10	WASHER 60 X 17,0 D, 10 THICK	WASHER 60 X 17,0 D, 10 THICK	
150		01.10.16045	2,000	SKT-SCHRAUBE M16X45 8.8	SCREW M16X45 DIN 933	SCREW M16X45 DIN 933	

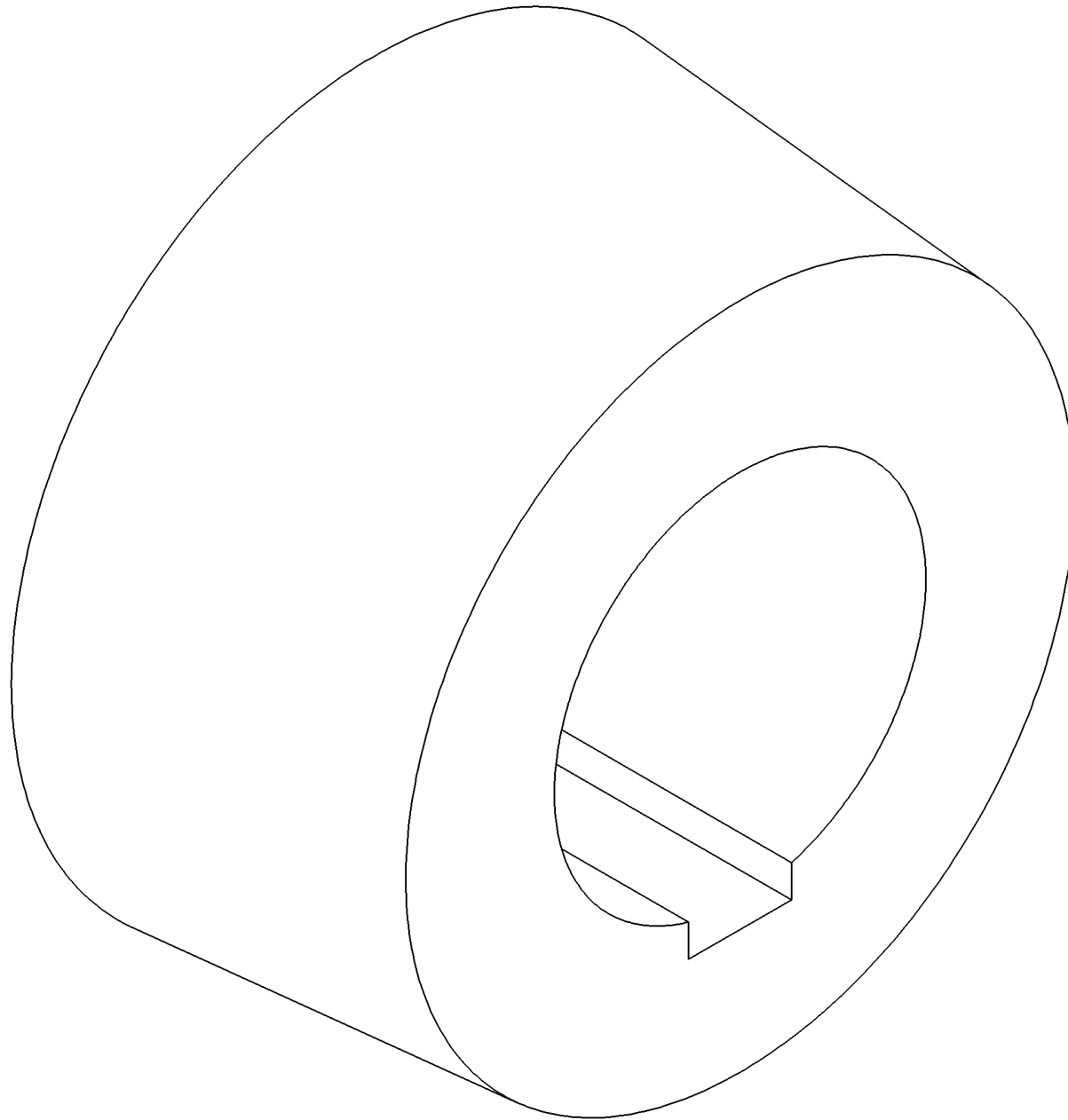



TAPERLOCK 3525 D65 - TAPERLOCK-BUSHING D 65 /3525
TAPERLOCK-BUSHING D 65 /3525 - 49.65.3525/00

49.65.3525/00

Stücklistennummer / Piece Number / Liste de Pièces / Номер



Pos.	Bestell-Nr. Stock Number Numéro de Commande Номер товара	Menge Amount Quantité Количество	Beschreibung	Description	Description	Описание
10	 49.1.3525	4,000	INBUSSCHRAUBE	SOCKET SCREW	SOCKET SCREW	
20	 49.1.3525	3,000	INBUSSCHRAUBE	SOCKET SCREW	SOCKET SCREW	

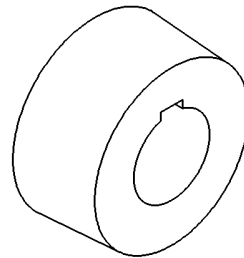

TAPERLOCK 3020 D50 - TAPERLOCK-BUSHING D 50 /3020
TAPERLOCK-BUSHING D 50 /3020 - 49.50.3020/00

49.50.3020/00

Stücklistennummer / Piece Number / Liste de Pièces / Номер



Pos.	Bestell-Nr. Stock Number Numéro de Commande Номер товара	Menge Amount Quantité Количество	Beschreibung	Description	Description	Описание
------	---	---	--------------	-------------	-------------	----------

10	49.1.3020	2,000	INBUSSCHRAUBE	SOCKET SCREW	SOCKET SCREW	
----	-----------	-------	---------------	--------------	--------------	--

DISTANZRING D75X4,5X18 - DISTANCE RING
DISTANCE RING - 796.6.2.66/B

796.6.2.66/B
Stücklistennummer / Piece Number / Liste de Pièces / Homep

Pinoth[®]

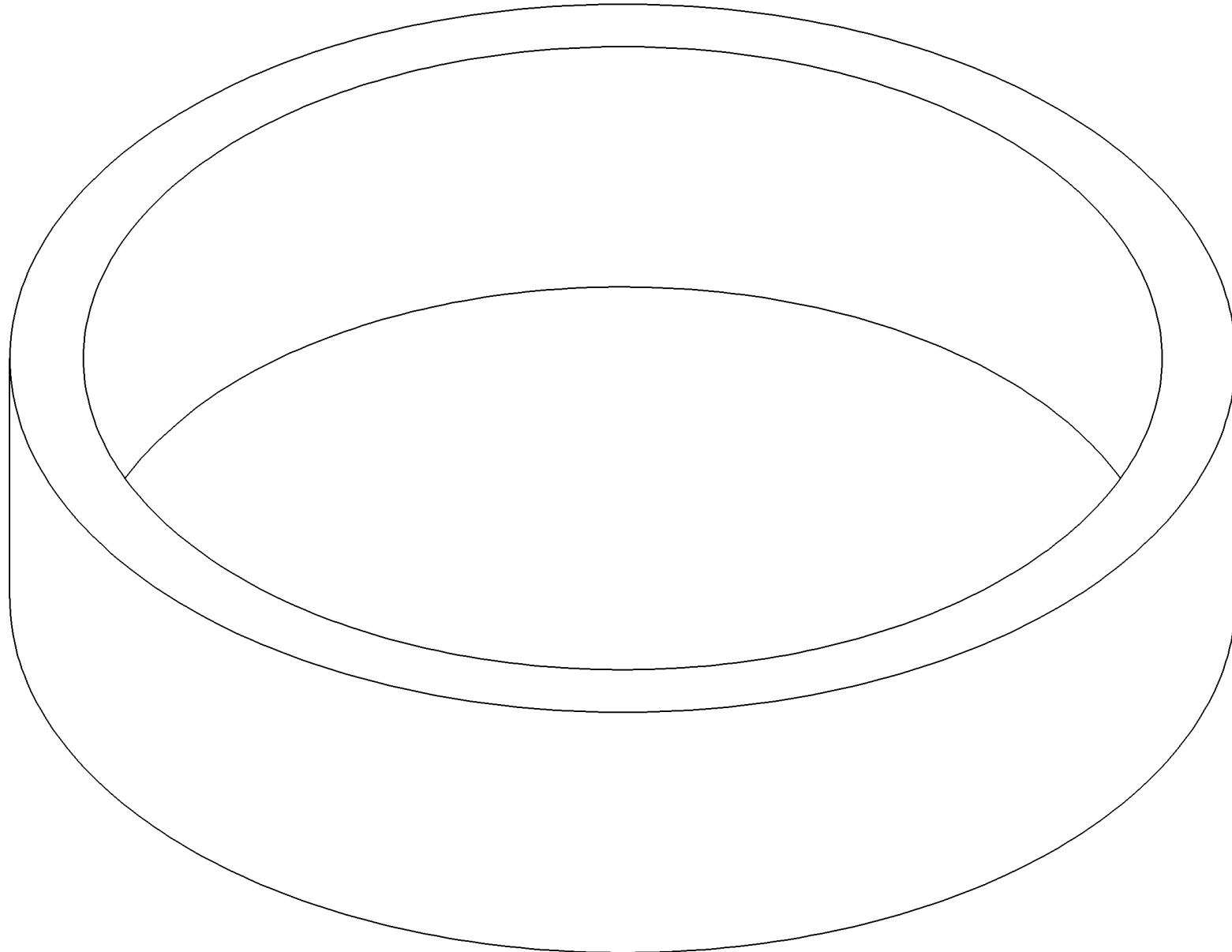

DISTANZRING D75X4,5X18 - DISTANCE RING
DISTANCE RING - 796.6.2.66/B

796.6.2.66/B
Stücklistennummer / Piece Number / Liste de Pièces / Номер



Pos.	Bestell-Nr. Stock Number Numéro de Commande Номер товара	Menge Amount Quantité Количество	Beschreibung	Description	Description	Описание
10	796.9.4.17.B	1,000	DISTANZRING D75X4,5X15	DISTANZRING D75X4,5X15	DISTANZRING D75X4,5X15	
20	754.20.5.08/00	1,000	DISTANZRING D75X4,5X3	DISTANCE RING	DISTANCE RING	

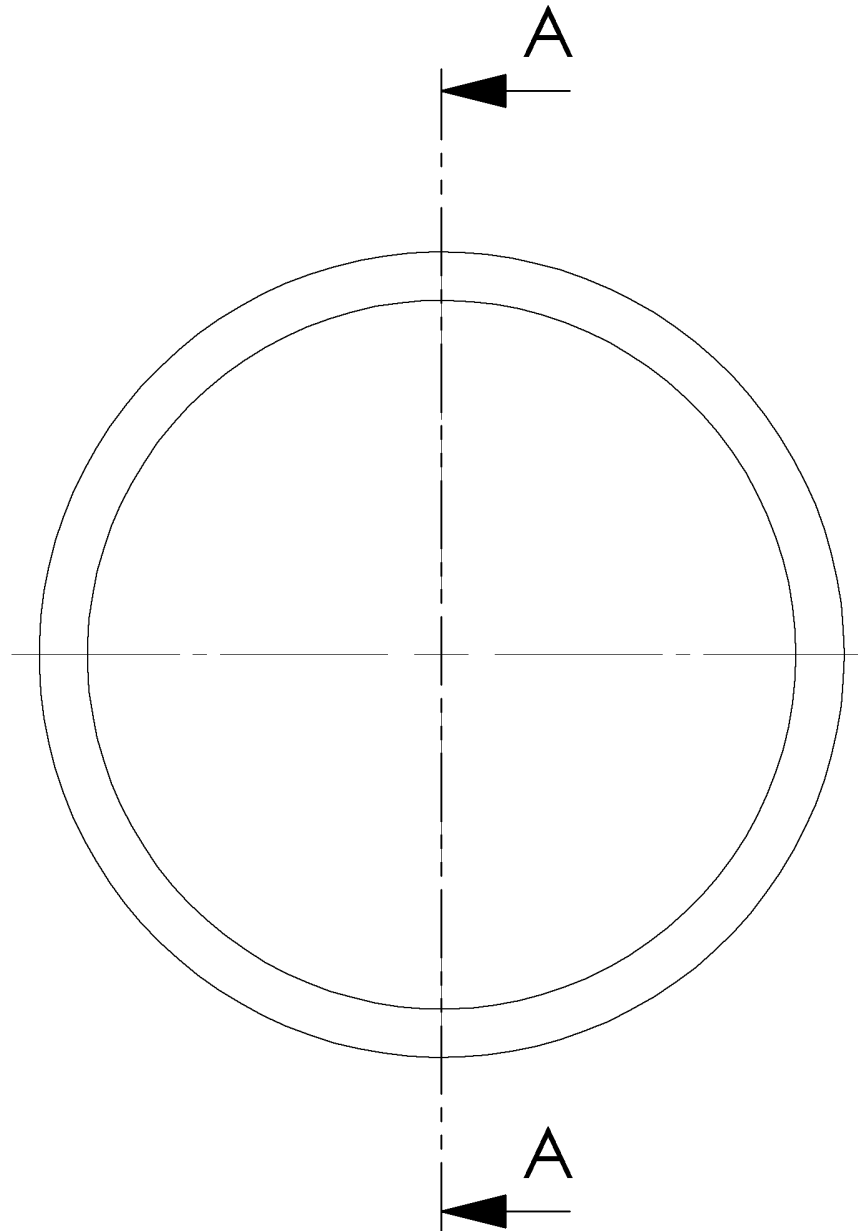

DISTANZRING D75X4,5X4 - DISTANCE RING
DISTANCE RING - 754.20.5.02/A

754.20.5.02/A
Stücklistennummer / Piece Number / Liste de Pièces / Номер



Pos.	Bestell-Nr. Stock Number Numéro de Commande Номер товара	Menge Amount Quantité Количество	Beschreibung	Description	Description	Описание
------	---	---	--------------	-------------	-------------	----------

10	 18.065.085.2	2,000	PASSSCHEIBE 65X85X2 GEOELT	ADJUSTING WASHER 65X85X2	ADJUSTING WASHER 65X85X2	
----	--	-------	----------------------------	--------------------------	--------------------------	--

DISTANZRING D75X4,5X4 - DISTANCE RING
DISTANCE RING - 754.20.5.02/A

754.20.5.02/A
Stücklistennummer / Piece Number / Liste de Pièces / Homep

Pinoth[®]

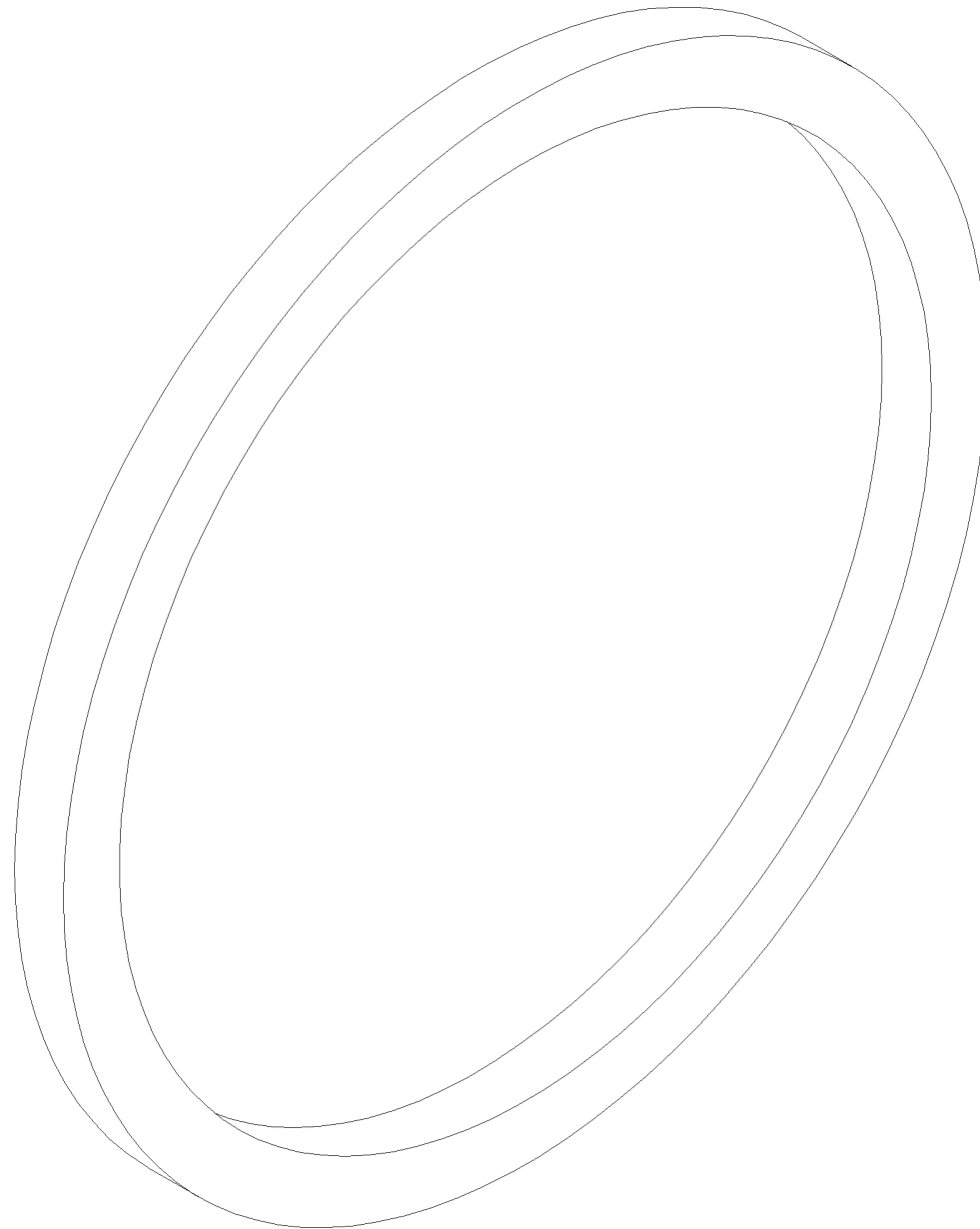

DISTANZRING D75X4,5X4 - DISTANCE RING
DISTANCE RING - 754.20.5.02/A

754.20.5.02/A
Stücklistennummer / Piece Number / Liste de Pièces / Номер



Pos.	Bestell-Nr. Stock Number Numéro de Commande Номер товара	Menge Amount Quantité Количество	Beschreibung	Description	Description	Описание
------	---	---	--------------	-------------	-------------	----------

10	 18.065.085.2	2,000	PASSSCHEIBE 65X85X2 GEOELT	ADJUSTING WASHER 65X85X2	ADJUSTING WASHER 65X85X2	
----	--	-------	----------------------------	--------------------------	--------------------------	--

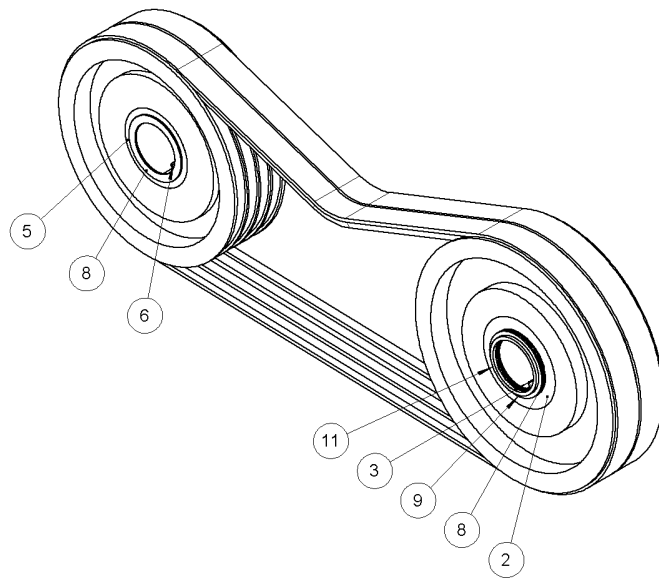
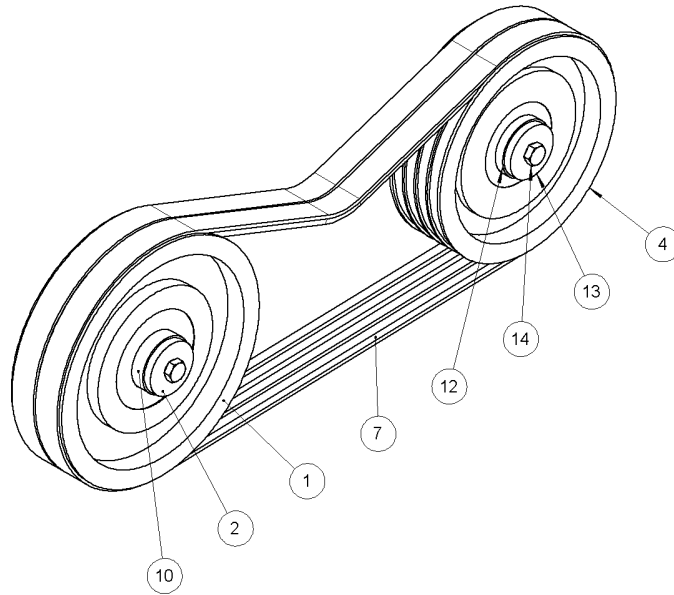



RIEMENUEBERSETZUNG I 1,13 - BELT RATIO I=1,13 - 160CCM
 BELT RATIO I=1,13 - 160CCM - 560.02.04.02.00/00

560.02.04.02.00/00
 Stücklistennummer / Piece Number / Liste de Pièces / Homep

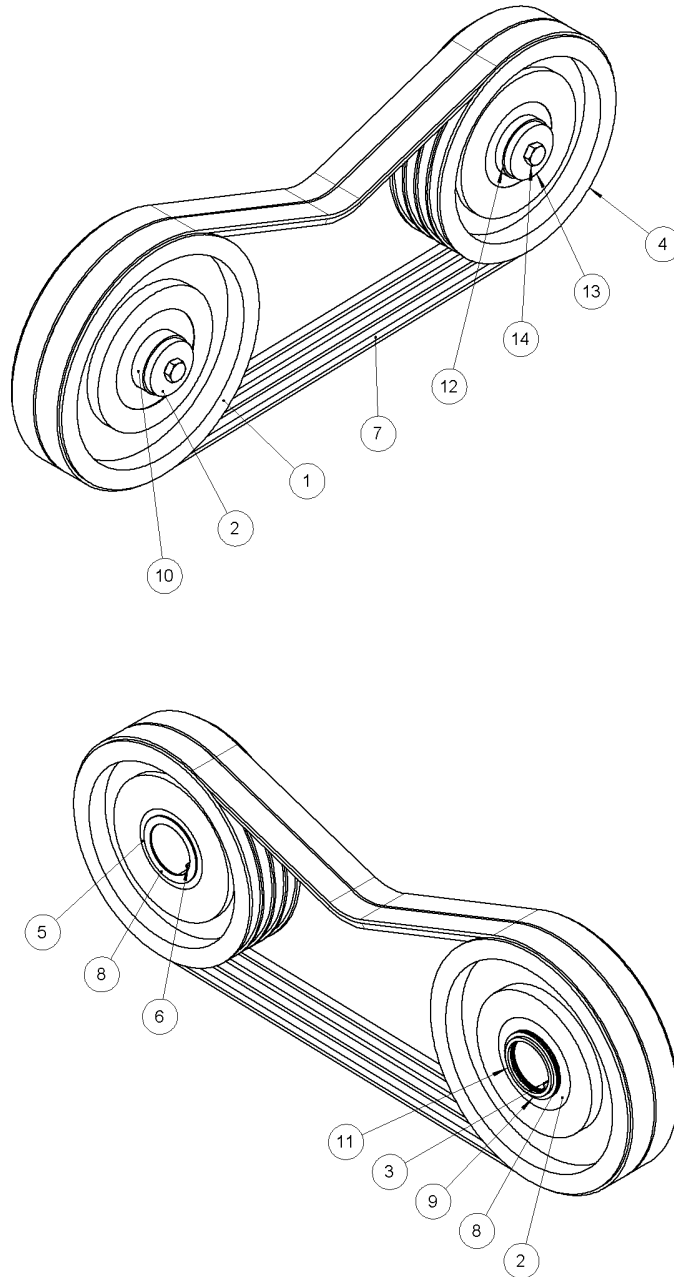

Pos.		Bestell-Nr. Stock Number Numéro de Commande Номер товара	Menge Amount Quantité Количество	Beschreibung	Description	Description	Описание
10		48.01.315.4/00	1,000	KEILRIEMENSCHLEIBE SPB 315X4 TL 3525 KM	V-BELT PULLEY 315X4	V-BELT PULLEY 315X4	
20		49.65.3525/00	1,000	<u>TAPERLOCK 3525 D65</u>	TAPERLOCK-BUSHING D 65 /3525	TAPERLOCK-BUSHING D 65 /3525	
30		09.18.11.63	1,000	PASSFEDER 18X11X63 FORM A	FEATHER KEY 18X11X63 DIN6885	FEATHER KEY 18X11X63 DIN6885	
40		48.01.280.4/00	1,000	KEILRIEMENSCHLEIBE SPB 280X4 TL 3020 KM	V-BELT PULLEY 280X4	V-BELT PULLEY 280X4	
50		49.65.3020/00	1,000	<u>TAPERLOCK 3020 D65</u>	TAPERLOCK-BUSHING D 65 /3020	TAPERLOCK-BUSHING D 65 /3020	
60		09.18.11.40	1,000	PASSFEDER 18X11X40 FORM A	FITTED KEY 18X11X40 DIN6885	FITTED KEY 18X11X40 DIN6885	
70		50.2.2187.B.Z.2	2,000	POWERBAND 2 HB 2187 LA AUSFUEHRUNG 7726	POWERBELT 2 HB 2187 LA	POWERBELT 2 HB 2187 LA	
80		18.065.085.1	4,000	PASSSCHEIBE 65X85X1 GEOELT	SPACER / WASHER 65X85X1	SPACER / WASHER 65X85X1	
90		18.065.085.2	2,000	PASSSCHEIBE 65X85X2 GEOELT	ADJUSTING WASHER 65X85X2	ADJUSTING WASHER 65X85X2	
100		796.6.2.66/B	1,000	<u>DISTANZRING D75X4.5X18</u>	DISTANCE RING	DISTANCE RING	
110		754.20.5.02/A	1,000	<u>DISTANZRING D75X4.5X4</u>	DISTANCE RING	DISTANCE RING	



Pos.	Bestell-Nr. Stock Number Numéro de Commande Номер товара	Menge Amount Quantité Количество	Beschreibung	Description	Description	Описание
120	 752.06.2.05	1,000	DISTANZRING D75X4,5X12	DISTANCE RING	DISTANCE RING	
130	 05.10.070.17.5.J	2,000	SCHEIBE 70XD17,5X10	DISC 70X17,5X10	DISC 70X17,5X10	
140	 01.10.16045	2,000	SKT-SCHRAUBE M16X45 8.8	SCREW M16X45 DIN 933	SCREW M16X45 DIN 933	

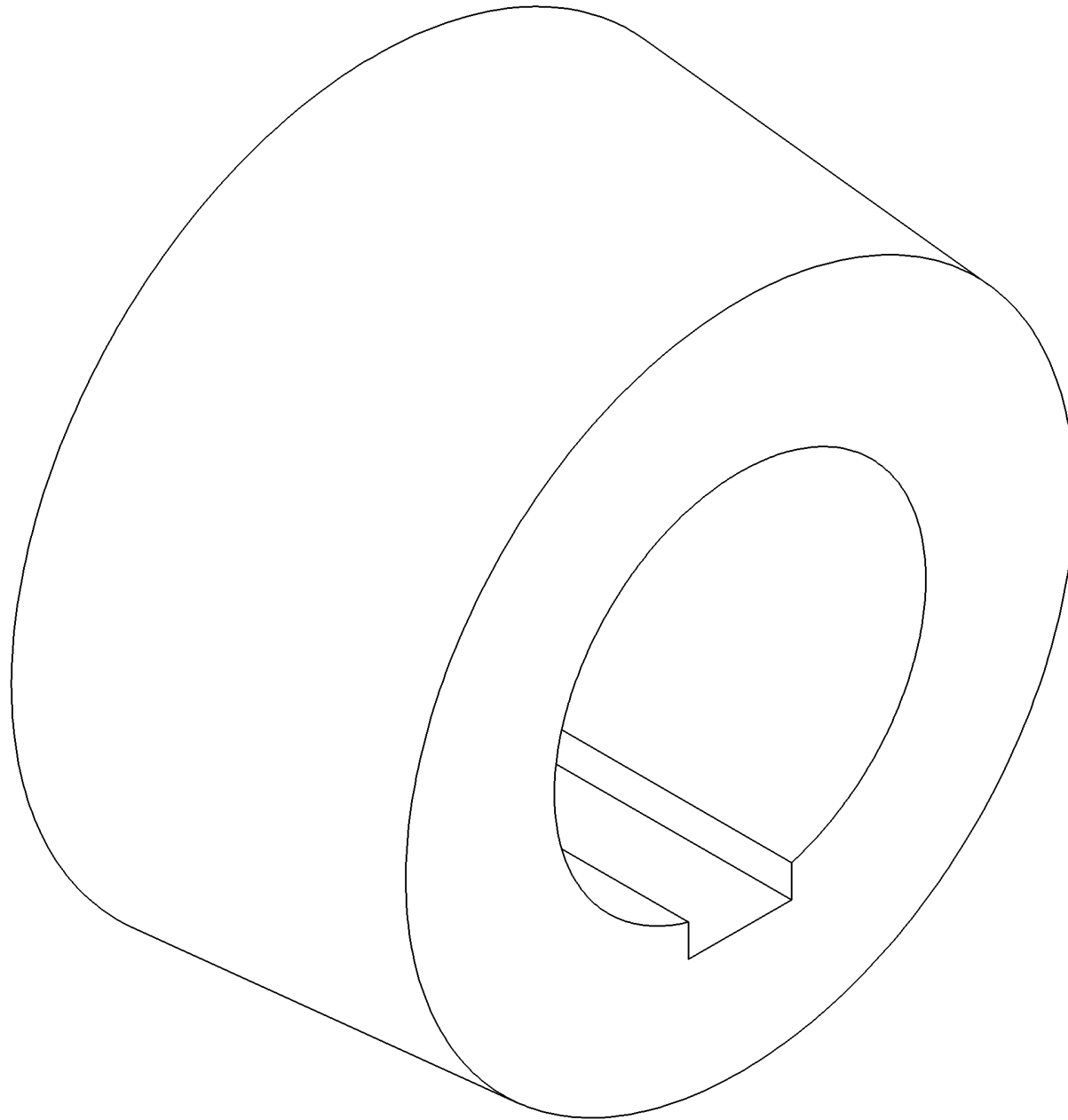



TAPERLOCK 3525 D65 - TAPERLOCK-BUSHING D 65 /3525
TAPERLOCK-BUSHING D 65 /3525 - 49.65.3525/00

49.65.3525/00

Stücklistennummer / Piece Number / Liste de Pièces / Номер



Pos.		Bestell-Nr. Stock Number Numéro de Commande Номер товара	Menge Amount Quantité Количество	Beschreibung	Description	Description	Описание
10		49.1.3525	4,000	INBUSSCHRAUBE	SOCKET SCREW	SOCKET SCREW	
20		49.1.3525	3,000	INBUSSCHRAUBE	SOCKET SCREW	SOCKET SCREW	

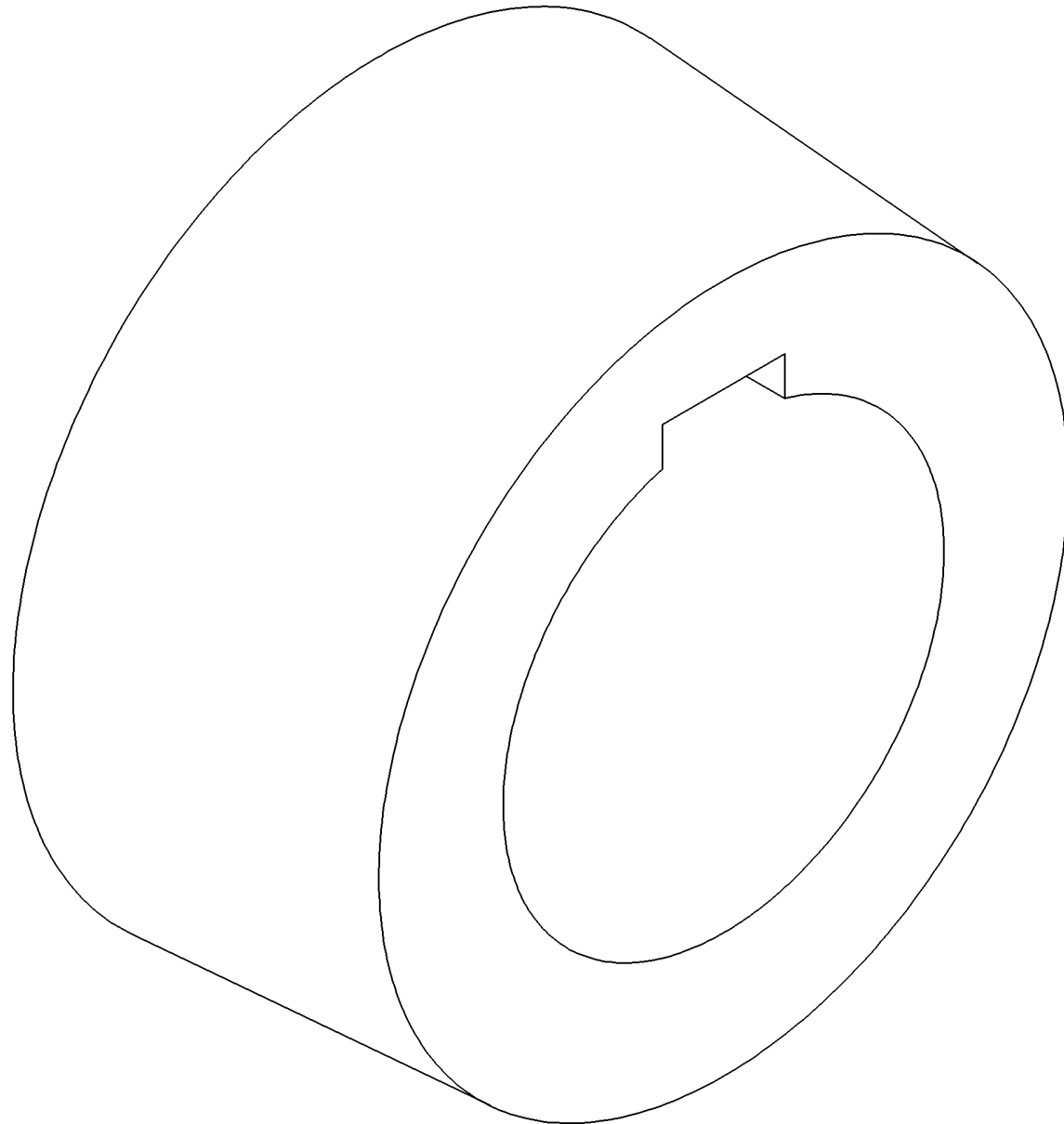

TAPERLOCK 3020 D65 - TAPERLOCK-BUSHING D 65 /3020
TAPERLOCK-BUSHING D 65 /3020 - 49.65.3020/00

49.65.3020/00

Stücklistennummer / Piece Number / Liste de Pièces / Номер



Pos.	Bestell-Nr. Stock Number Numéro de Commande Номер товара	Menge Amount Quantité Количество	Beschreibung	Description	Description	Описание
------	---	---	--------------	-------------	-------------	----------

10	49.1.3020	2,000	INBUSSCHRAUBE	SOCKET SCREW	SOCKET SCREW	
----	-----------	-------	---------------	--------------	--------------	--

DISTANZRING D75X4,5X18 - DISTANCE RING
DISTANCE RING - 796.6.2.66/B

796.6.2.66/B
Stücklistennummer / Piece Number / Liste de Pièces / Homep

Pinoth[®]

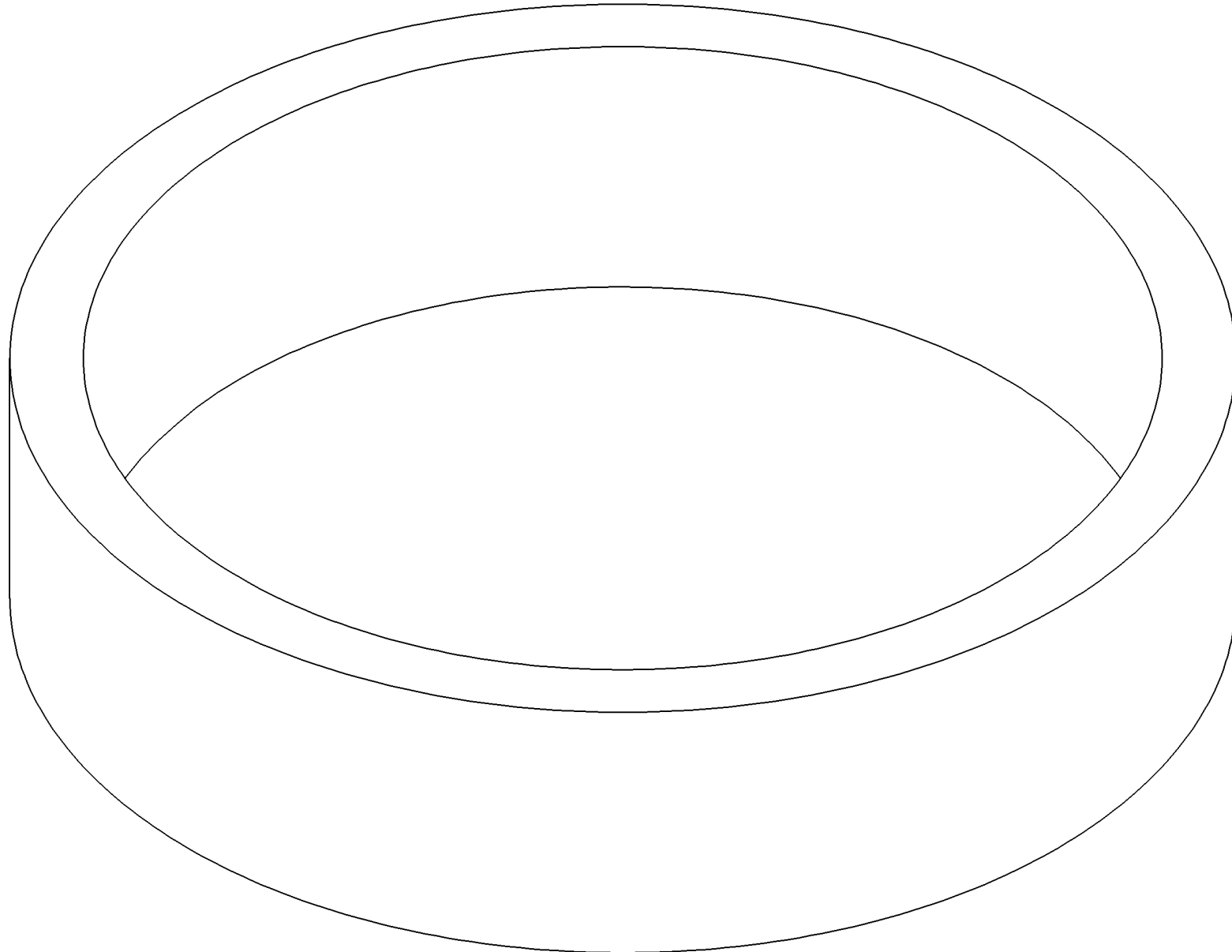

DISTANZRING D75X4,5X18 - DISTANCE RING
DISTANCE RING - 796.6.2.66/B

796.6.2.66/B
Stücklistennummer / Piece Number / Liste de Pièces / Номер



Pos.	Bestell-Nr. Stock Number Numéro de Commande Номер товара	Menge Amount Quantité Количество	Beschreibung	Description	Description	Описание
10	796.9.4.17.B	1,000	DISTANZRING D75X4,5X15	DISTANZRING D75X4,5X15	DISTANZRING D75X4,5X15	
20	754.20.5.08/00	1,000	DISTANZRING D75X4,5X3	DISTANCE RING	DISTANCE RING	

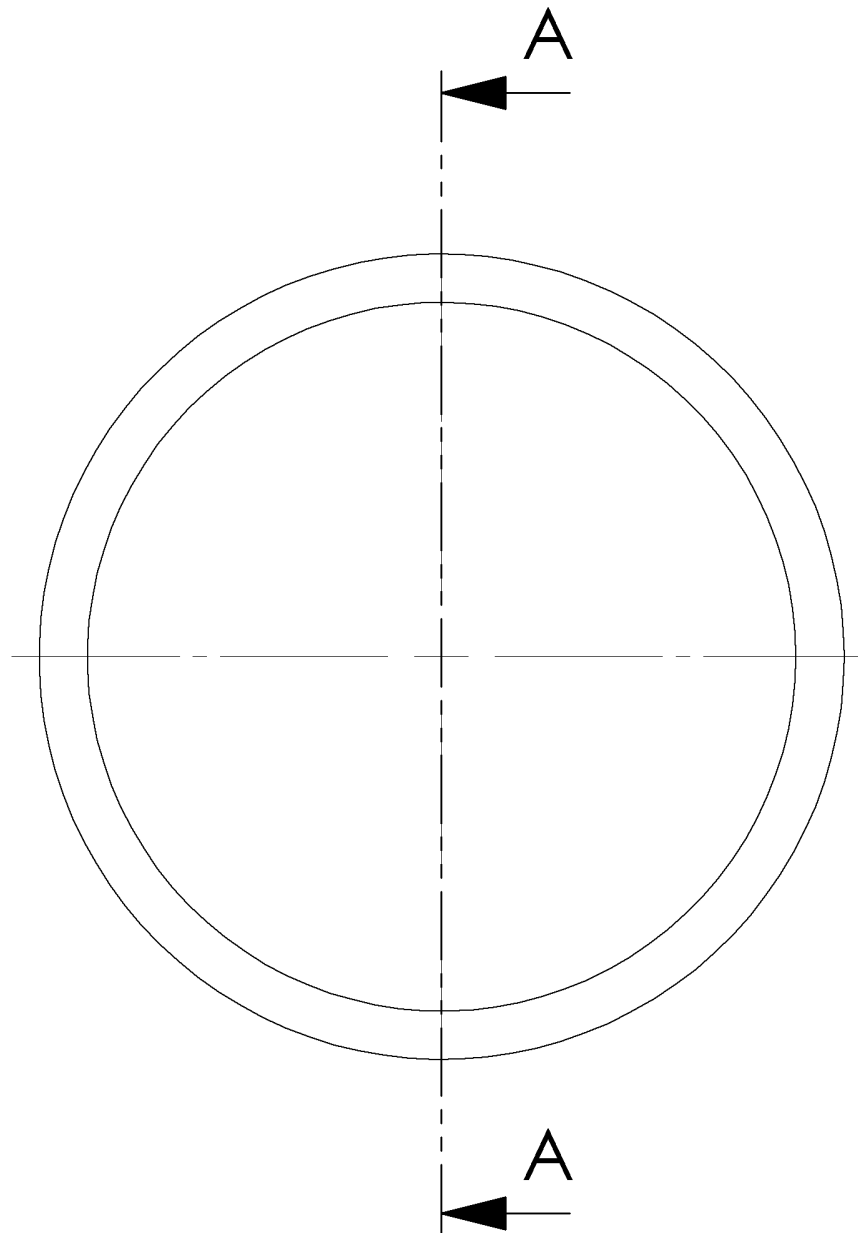

DISTANZRING D75X4,5X4 - DISTANCE RING
DISTANCE RING - 754.20.5.02/A

754.20.5.02/A
Stücklistennummer / Piece Number / Liste de Pièces / Номер



Pos.	Bestell-Nr. Stock Number Numéro de Commande Номер товара	Menge Amount Quantité Количество	Beschreibung	Description	Description	Описание
------	---	---	--------------	-------------	-------------	----------

10	 18.065.085.2	2,000	PASSSCHEIBE 65X85X2 GEOELT	ADJUSTING WASHER 65X85X2	ADJUSTING WASHER 65X85X2	
----	--	-------	----------------------------	--------------------------	--------------------------	--

DISTANZRING D75X4,5X4 - DISTANCE RING
DISTANCE RING - 754.20.5.02/A

754.20.5.02/A
Stücklistennummer / Piece Number / Liste de Pièces / Homep

Pinoth[®]

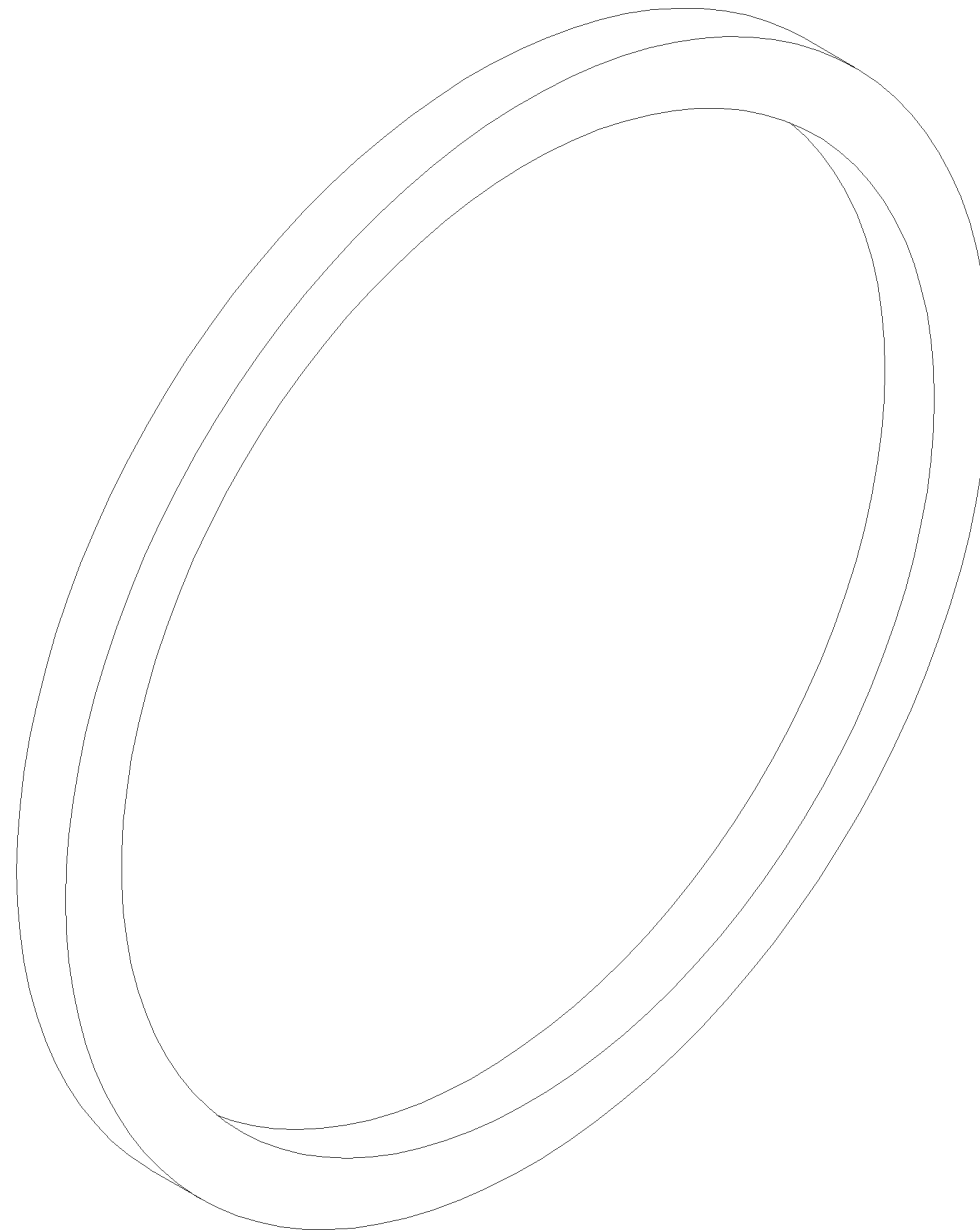

DISTANZRING D75X4,5X4 - DISTANCE RING
DISTANCE RING - 754.20.5.02/A

754.20.5.02/A
Stücklistennummer / Piece Number / Liste de Pièces / Номер



Pos.	Bestell-Nr. Stock Number Numéro de Commande Номер товара	Menge Amount Quantité Количество	Beschreibung	Description	Description	Описание
------	---	---	--------------	-------------	-------------	----------

10	 18.065.085.2	2,000	PASSSCHEIBE 65X85X2 GEOELT	ADJUSTING WASHER 65X85X2	ADJUSTING WASHER 65X85X2	
----	--	-------	----------------------------	--------------------------	--------------------------	--

DISTANZRING D75X4,5X12 - DISTANCE RING
DISTANCE RING - 752.06.2.05

752.06.2.05

Stücklistennummer / Piece Number / Liste de Pièces / Homep



DISTANZRING D75X4,5X12 - DISTANCE RING
DISTANCE RING - 752.06.2.05



752.06.2.05
Stücklistennummer / Piece Number / Liste de Pièces / Номер





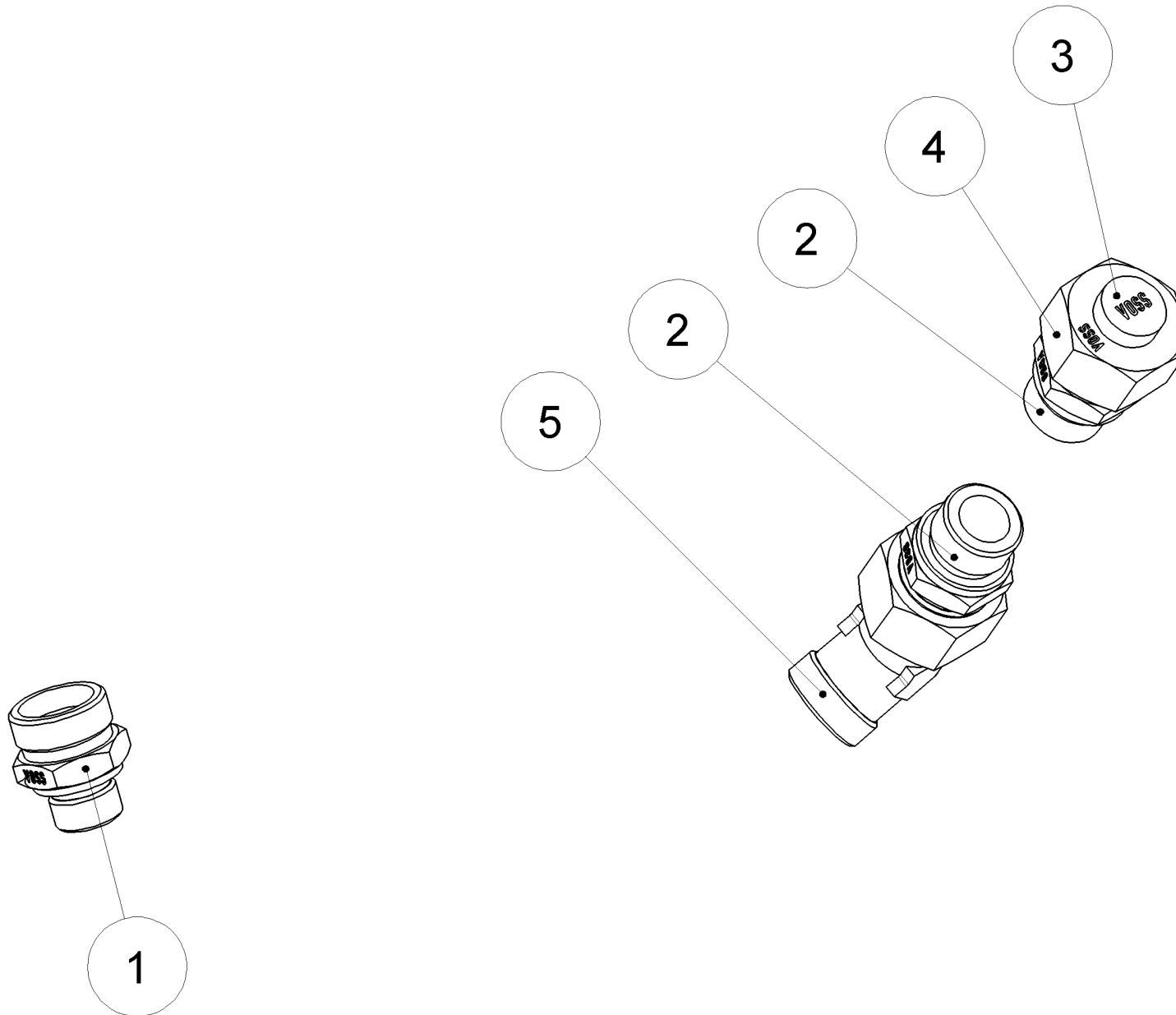

Pos.	Bestell-Nr. Stock Number Numéro de Commande Номер товара	Menge Amount Quantité Количество	Beschreibung	Description	Description	Описание
------	---	---	--------------	-------------	-------------	----------

20	 18.065.085.1	1,000	PASSSCHEIBE 65X85X1 GEOELT	SPACER / WASHER 65X85X1	SPACER / WASHER 65X85X1	
----	--	-------	----------------------------	-------------------------	-------------------------	--

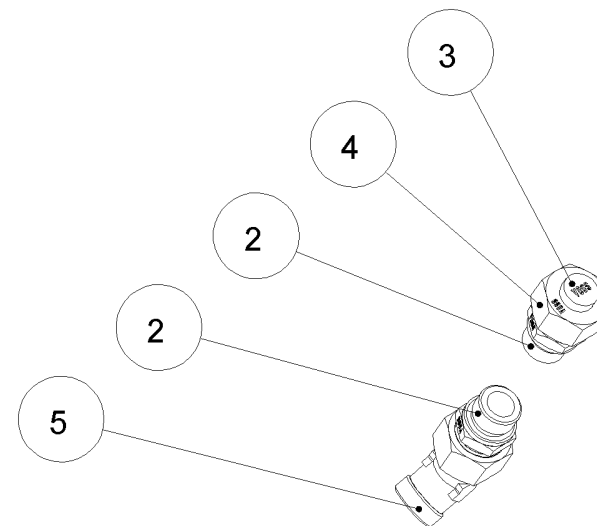
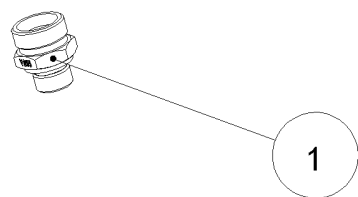

Pos.		Bestell-Nr. Stock Number Numéro de Commande Номер товара	Menge Amount Quantité Количество	Beschreibung	Description	Description	Описание
10		20.GEV18L.M18-1.5/00	1,000	GER-EINSCHR-VERSCHR. 18L	STRAIGHT TUBE FITT. 18L18X1,5	STRAIGHT TUBE FITT. 18L18X1,5	
20		20.GEV18L.M22-1.5/00	2,000	GER-EINSCHR-VERSCHR. 18L	STRAIGHT SCREW FIT. 18L 22X1,5	STRAIGHT SCREW FIT. 18L 22X1,5	
30		20.BUZ18L/00	1,000	VERSCHLUSSTOPFEN 18L PN400 SW32	FITTING FOR MEASURE 18L C/ NUT	FITTING FOR MEASURE 18L C/ NUT	
40		20.UEM18L/00	1,000	UEBERWURFMUTTER 18L M26X1,5 PN400, SW32	UNION NUT 18L M26-1.5	UNION NUT 18L M26-1.5	
50		20.EWV18L.45/00	1,000	EINSTELLBARE-VERSCHR. EV 18L PN315 45G	ADJUSTABLE SCREWING 18L	ADJUSTABLE SCREWING 18L	
60		20.02.14.18.1000.B/00	1,000	HYDRAULIKSCHLAUCH	HYDRAULIC HOSE	BOYAU HYDRAULIQUE	



Pos.		Bestell-Nr. Stock Number Numéro de Commande Номер товара	Menge Amount Quantité Количество	Beschreibung	Description	Description	Описание
10		20.GEV18L.M18-1.5/00	1,000	GER-EINSCHR-VERSCHR. 18L	STRAIGHT TUBE FITT. 18L18X1,5	STRAIGHT TUBE FITT. 18L18X1,5	
20		20.GEV18L.M22-1.5/00	2,000	GER-EINSCHR-VERSCHR. 18L	STRAIGHT SCREW FIT. 18L 22X1,5	STRAIGHT SCREW FIT. 18L 22X1,5	
30		20.BUZ18L/00	1,000	VERSCHLUSSTOPFEN 18L PN400 SW32	FITTING FOR MEASURE 18L C/ NUT	FITTING FOR MEASURE 18L C/ NUT	
40		20.UEM18L/00	1,000	UEBERWURFMUTTER 18L M26X1,5 PN400, SW32	UNION NUT 18L M26-1.5	UNION NUT 18L M26-1.5	
50		20.EWV18L.45/00	1,000	EINSTELLBARE-VERSCHR. EV 18L PN315 45G	ADJUSTABLE SCREWING 18L	ADJUSTABLE SCREWING 18L	
60		20.02.14.18.1000.B/00	1,000	HYDRAULIKSCHLAUCH	HYDRAULIC HOSE	BOYAU HYDRAULIQUE	

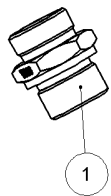
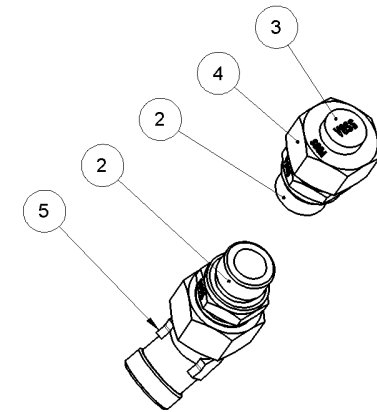







LECKOELVERSCHRAUBUNG DIN FUER 160CCM - LEAK-OIL FITTING - 160CCM DIN
 LEAK-OIL FITTING - 160CCM DIN - 560.15.00.04.00/A

560.15.00.04.00/A

Stücklistennummer / Piece Number / Liste de Pièces / Номер





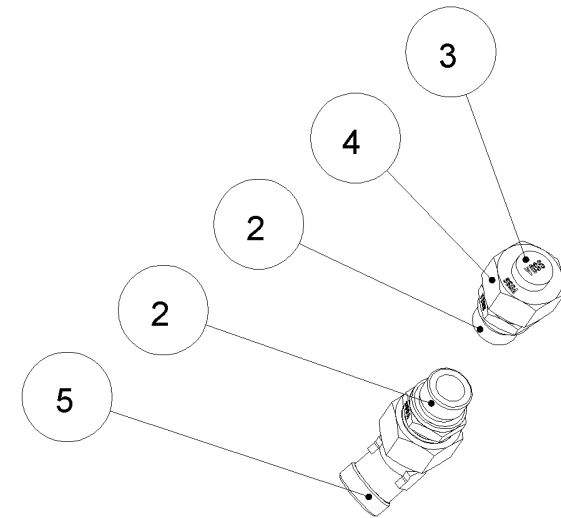
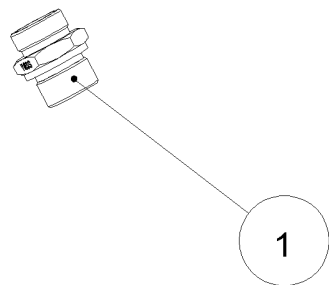



Pos.		Bestell-Nr. Stock Number Numéro de Commande Номер товара	Menge Amount Quantité Количество	Beschreibung	Description	Description	Описание
10		20.GEV18L.M26-1.5/00	1,000	GER-EINSCHR-VERSCHR. 18L M26X1,5, PN400	MALE STUD COUPLING 18L M26-1.5	MALE STUD COUPLING 18L M26-1.5	
20		20.GEV18L.M22-1.5/00	2,000	GER-EINSCHR-VERSCHR. 18L	STRAIGHT SCREW FIT. 18L 22X1,5	STRAIGHT SCREW FIT. 18L 22X1,5	
30		20.BUZ18L/00	1,000	VERSCHLUSSTOPFEN 18L PN400 SW32	FITTING FOR MEASURE 18L C/ NUT	FITTING FOR MEASURE 18L C/ NUT	
40		20.UEM18L/00	1,000	UEBERWURFMUTTER 18L M26X1,5 PN400, SW32	UNION NUT 18L M26-1.5	UNION NUT 18L M26-1.5	
50		20.EWV18L.45/00	1,000	EINSTELLBARE-VERSCHR. EV 18L PN315 45G	ADJUSTABLE SCREWING 18L	ADJUSTABLE SCREWING 18L	
60		20.02.14.18.1000.B/00	1,000	HYDRAULIKSCHLAUCH	HYDRAULIC HOSE	BOYAU HYDRAULIQUE	







LECKOELVERSCHRAUBUNG DIN FUER 160CCM - LEAK-OIL FITTING - 160CCM DIN
 LEAK-OIL FITTING - 160CCM DIN - 560.15.00.04.00/A

560.15.00.04.00/A
 Stücklistennummer / Piece Number / Liste de Pièces / Номер

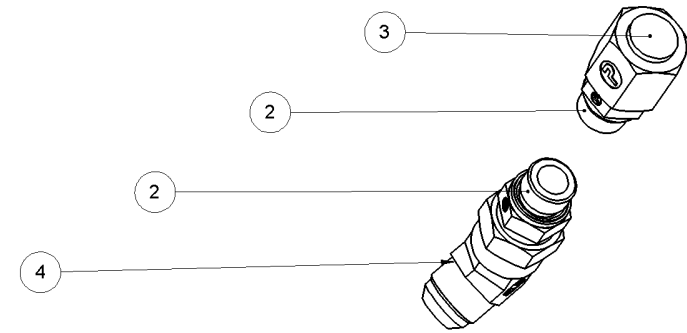
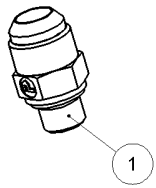



Pos.		Bestell-Nr. Stock Number Numéro de Commande Номер товара	Menge Amount Quantité Количество	Beschreibung	Description	Description	Описание
10		20.GEV18L.M26-1.5/00	1,000	GER-EINSCHR-VERSCHR. 18L M26X1,5, PN400	MALE STUD COUPLING 18L M26-1.5	MALE STUD COUPLING 18L M26-1.5	
20		20.GEV18L.M22-1.5/00	2,000	GER-EINSCHR-VERSCHR. 18L	STRAIGHT SCREW FIT. 18L 22X1,5	STRAIGHT SCREW FIT. 18L 22X1,5	
30		20.BUZ18L/00	1,000	VERSCHLUSSTOPFEN 18L PN400 SW32	FITTING FOR MEASURE 18L C/ NUT	FITTING FOR MEASURE 18L C/ NUT	
40		20.UEM18L/00	1,000	UEBERWURFMUTTER 18L M26X1,5 PN400, SW32	UNION NUT 18L M26-1.5	UNION NUT 18L M26-1.5	
50		20.EWV18L.45/00	1,000	EINSTELLBARE-VERSCHR. EV 18L PN315 45G	ADJUSTABLE SCREWING 18L	ADJUSTABLE SCREWING 18L	
60		20.02.14.18.1000.B/00	1,000	HYDRAULIKSCHLAUCH	HYDRAULIC HOSE	BOYAU HYDRAULIQUE	

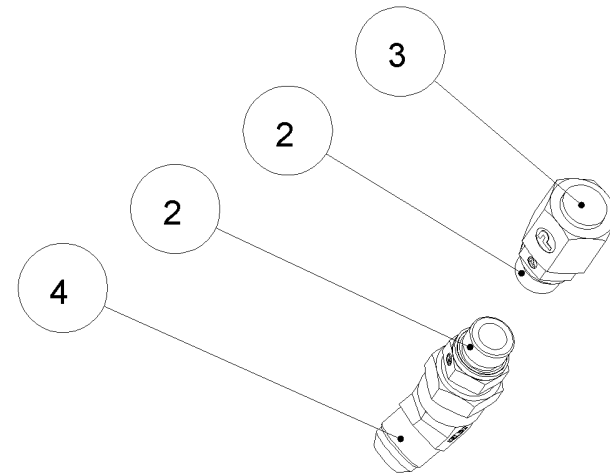
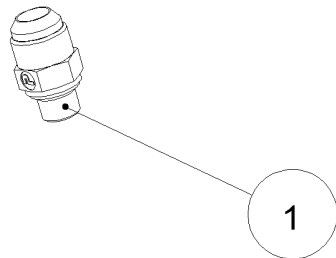

Pos.	Bestell-Nr. Stock Number Numéro de Commande Номер товара	Menge Amount Quantité Количество	Beschreibung	Description	Description	Описание
10	 20.04.00011/00	1,000	EINSCHRAUBSTUTZEN JIC37	MALE STUD	MALE STUD	
20	 20.04.00035/00	2,000	EINSCHRAUBSTUTZEN JIC37 18	EINSCHRAUBSTUTZEN JIC37 18	EINSCHRAUBSTUTZEN JIC37 18	
30	 20.04.00016/00	1,000	VERSCHLUSSKAPPE JIC37 18L PN350	END PLUG JIC37 18L	END PLUG JIC37 18L	
50	20.02.00464/00	1,000	HYDRAULIKSCHLAUCH	HYDRAULIC HOSE	BOYAU HYDRAULIQUE	



Pos.	Bestell-Nr. Stock Number Numéro de Commande Номер товара	Menge Amount Quantité Количество	Beschreibung	Description	Description	Описание
10	 20.04.00011/00	1,000	EINSCHRAUBSTUTZEN JIC37	MALE STUD	MALE STUD	
20	 20.04.00035/00	2,000	EINSCHRAUBSTUTZEN JIC37 18	EINSCHRAUBSTUTZEN JIC37 18	EINSCHRAUBSTUTZEN JIC37 18	
30	 20.04.00016/00	1,000	VERSCHLUSSKAPPE JIC37 18L PN350	END PLUG JIC37 18L	END PLUG JIC37 18L	
50	20.02.00464/00	1,000	HYDRAULIKSCHLAUCH	HYDRAULIC HOSE	BOYAU HYDRAULIQUE	

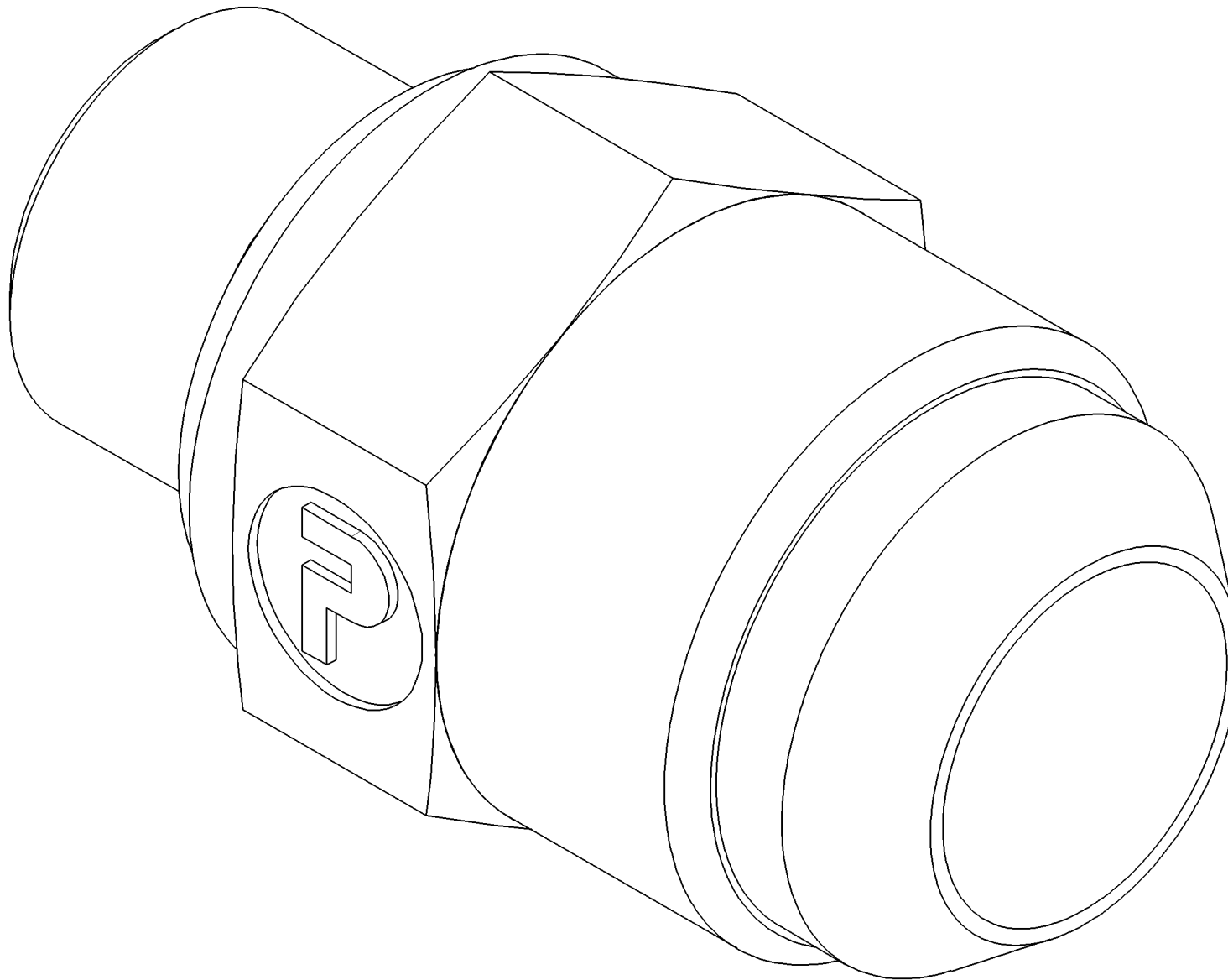

EINSCHRAUBSTUTZEN JIC37 - MALE STUD
MALE STUD - 20.04.00011/00





20.04.00011/00
Stücklistennummer / Piece Number / Liste de Pièces / Номер



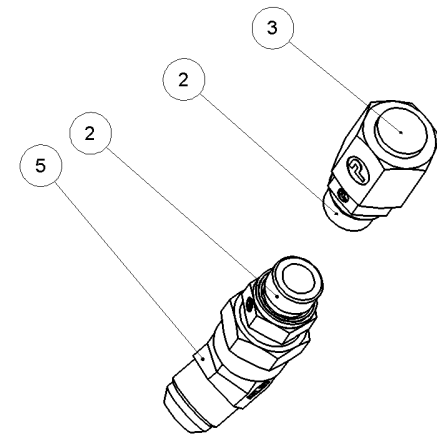
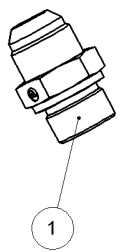



Pos.	Bestell-Nr. Stock Number Numéro de Commande Номер товара	Menge Amount Quantité Количество	Beschreibung	Description	Description	Описание
------	---	---	--------------	-------------	-------------	----------

10	20.04.00011.01	1,000	KAMMERRING	KAMMERRING	KAMMERRING	
----	----------------	-------	------------	------------	------------	--

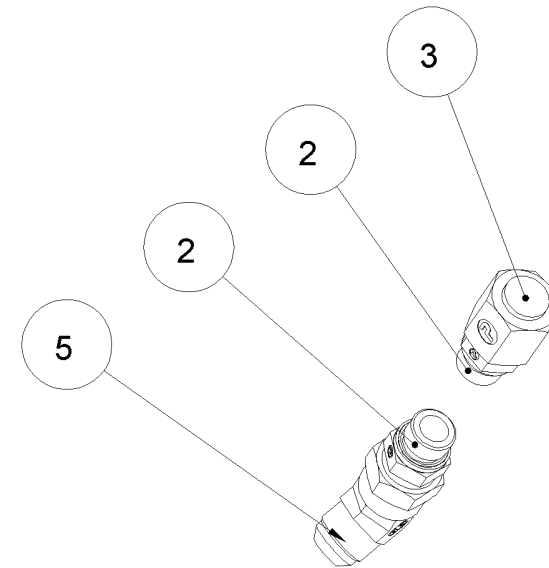
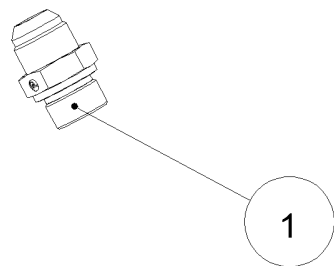

Pos.		Bestell-Nr. Stock Number Numéro de Commande Номер товара	Menge Amount Quantité Количество	Beschreibung	Description	Description	Описание
10		20.04.00061/00	1,000	EINSCHRAUBSTUTZEN JIC37 18,20	EINSCHRAUBSTUTZEN JIC37 18,20	EINSCHRAUBSTUTZEN JIC37 18,20	
20		20.04.00035/00	2,000	EINSCHRAUBSTUTZEN JIC37 18	EINSCHRAUBSTUTZEN JIC37 18	EINSCHRAUBSTUTZEN JIC37 18	
30		20.04.00016/00	1,000	VERSCHLUSSKAPPE JIC37 18L PN350	END PLUG JIC37 18L	END PLUG JIC37 18L	
40		20.02.00464/00	1,000	HYDRAULIKSCHLAUCH	HYDRAULIC HOSE	BOYAU HYDRAULIQUE	





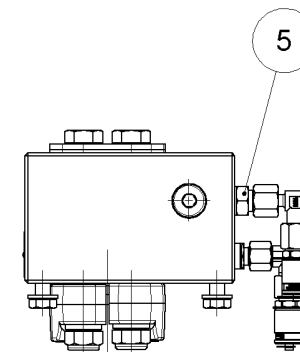
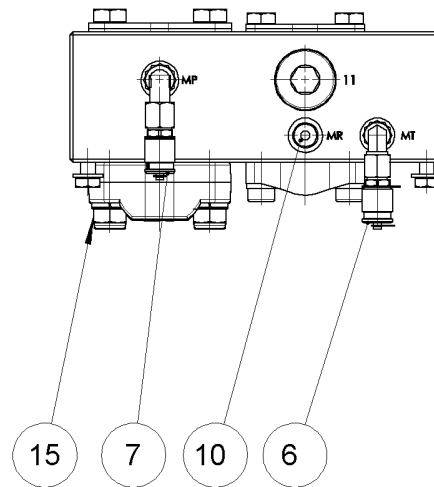
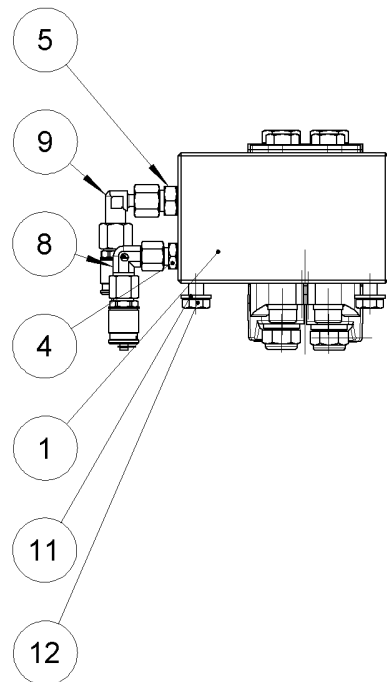
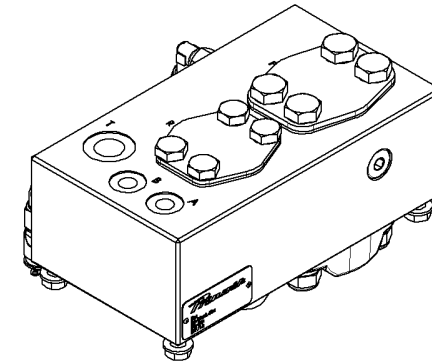
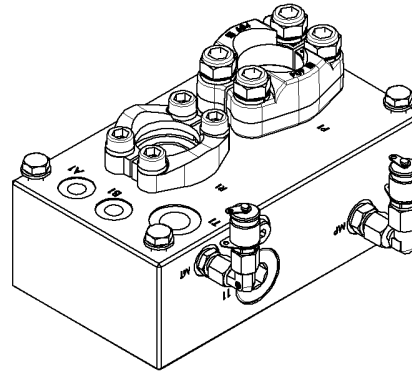
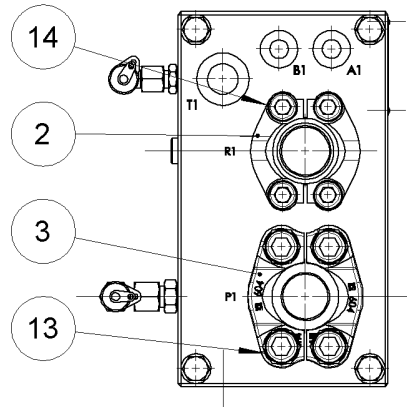

Pos.		Bestell-Nr. Stock Number Numéro de Commande Номер товара	Menge Amount Quantité Количество	Beschreibung	Description	Description	Описание
10		20.04.00061/00	1,000	EINSCHRAUBSTUTZEN JIC37 18,20	EINSCHRAUBSTUTZEN JIC37 18,20	EINSCHRAUBSTUTZEN JIC37 18,20	
20		20.04.00035/00	2,000	EINSCHRAUBSTUTZEN JIC37 18	EINSCHRAUBSTUTZEN JIC37 18	EINSCHRAUBSTUTZEN JIC37 18	
30		20.04.00016/00	1,000	VERSCHLUSSKAPPE JIC37 18L PN350	END PLUG JIC37 18L	END PLUG JIC37 18L	
40		20.02.00464/00	1,000	HYDRAULIKSCHLAUCH	HYDRAULIC HOSE	BOYAU HYDRAULIQUE	

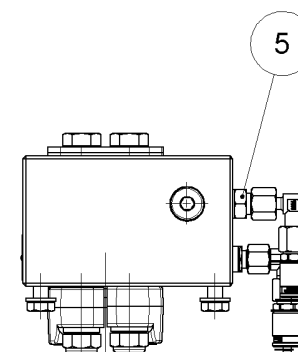
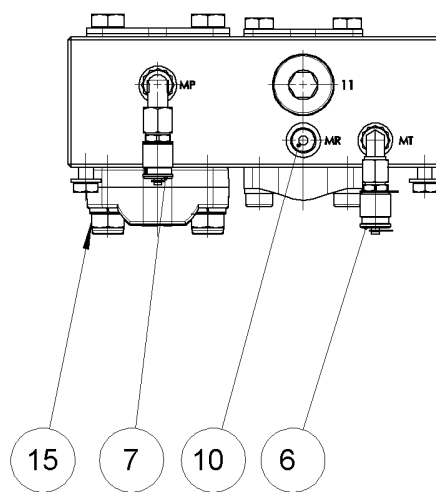
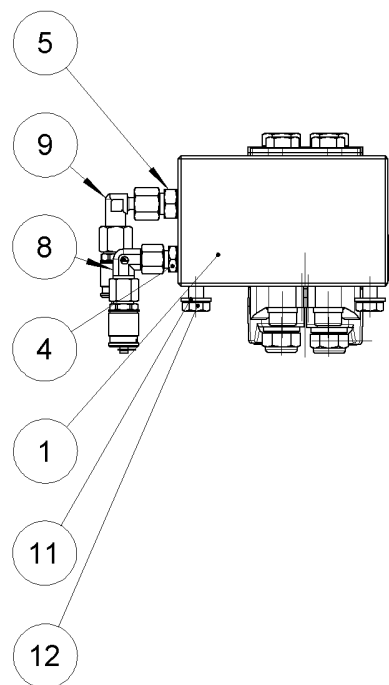
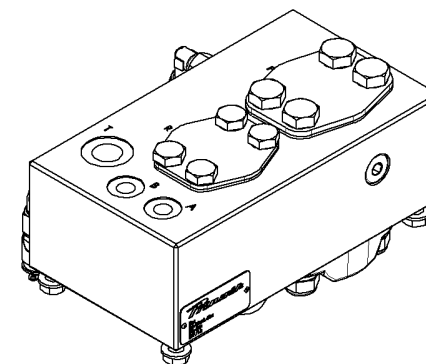
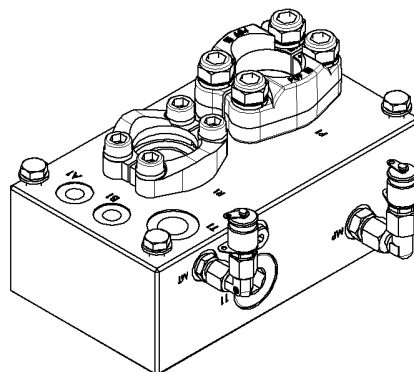
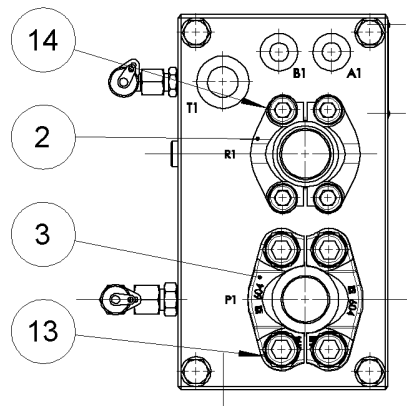

Pos.		Bestell-Nr. Stock Number Numéro de Commande Номер товара	Menge Amount Quantité Количество	Beschreibung	Description	Description	Описание
10		20.60.045/A	1,000	ANSCHLUSSBLOCK	ANSCHLUSSBLOCK	ANSCHLUSSBLOCK	
20		20.29.002/00	1,000	SAE-HALBFLANSCH 1 1/4 3000 PSI M12	SAE-HALF FLANGE 1 1/4"	SAE-HALF FLANGE 1 1/4"	
30		20.29.005/A	1,000	SAE-HALBFLANSCH 1 1/4 6000 PSI	SAE-HALBFLANSCH 1 1/4 6000 PSI	SAE-HALBFLANSCH 1 1/4 6000 PSI	
40		20.GEV08L.M12-1.5/00	1,000	GER-EINSCHR-VERSCHR. 8L	MALE STUD COUPLING 08L M12-1.5	MALE STUD COUPLING 08L M12-1.5	
50		20.GEV08S.M14-1.5/00	1,000	GER-EINSCHR-VERSCHR. 8S	STRAIGHT SCREW FITT. 8S 14X1,5	STRAIGHT SCREW FITT. 8S 14X1,5	
60		20.41.001/00	1,000	PRUEFANSCHLUSS MINIMESS 8L SMK 20	FITTING MEASUREMENT 8L/ SMK20	FITTING MEASUREMENT 8L/ SMK20	
70		20.41.002/00	1,000	PRUEFANSCHLUSS MINIMESS 8S SMK 20	PRUEFANSCHLUSS MINIMESS 8S SMK 20	PRUEFANSCHLUSS MINIMESS 8S SMK 20	
80		20.EWV08L/00	1,000	EINSTELLBARE-VERSCHR. EW 8L PN500	HYDR. FITTING EWV 8L	HYDR. FITTING EWV 8L	
90		20.EWV08S	1,000	EINSTELLBARE-VERSCHR. EW 8S PN800	HYDR. FITTING EWV 8S	HYDR. FITTING EWV 8S	
100		20.VS12.1.5/00	1,000	VERSCHLUSSSCHRAUBE M12X1,5 PN400, I-SW6	LOCK SCREW M12X1,5	LOCK SCREW M12X1,5	
110		05.01.10	4,000	SCHEIBE ISO 7090-10-200HV	WASHER B10,5 DIN 125 GALV.	WASHER B10,5 DIN 125 GALV.	





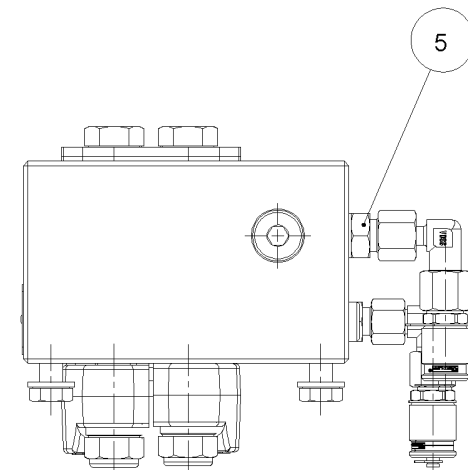
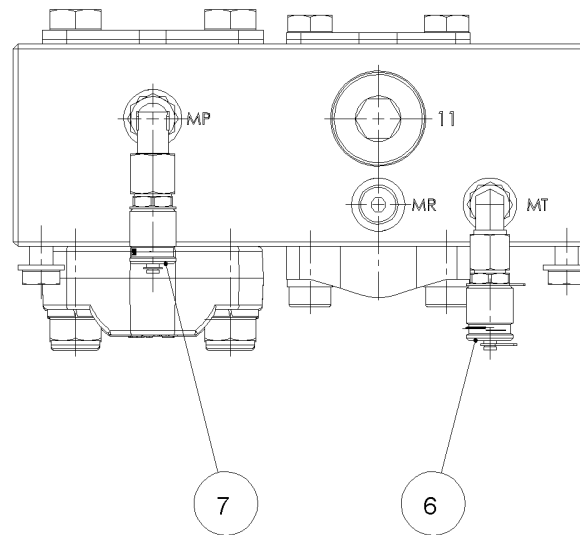
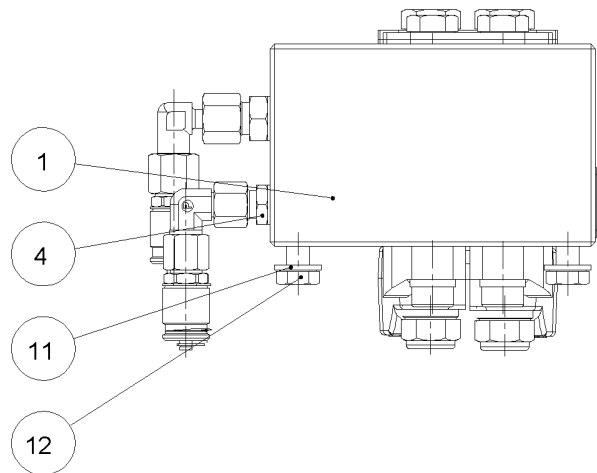
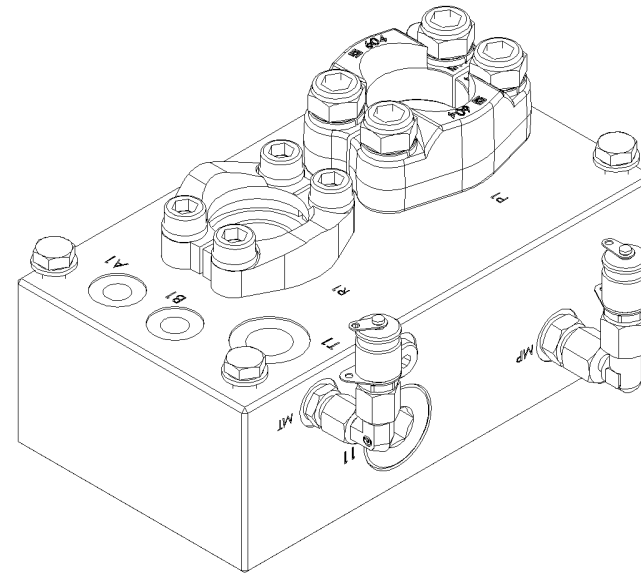
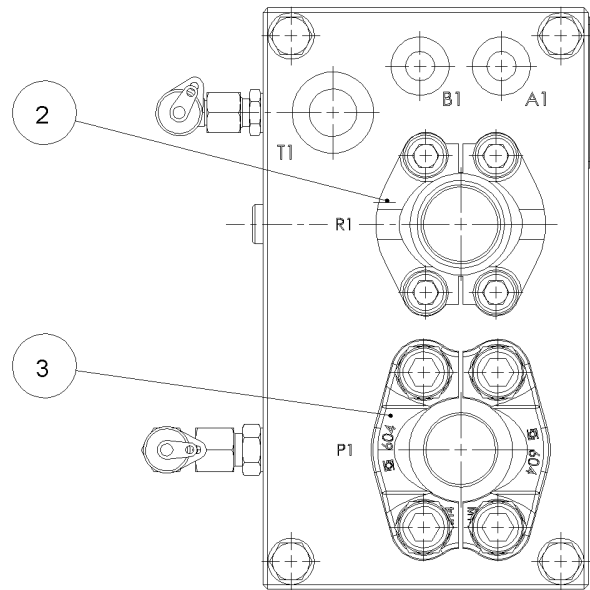

Pos.		Bestell-Nr. Stock Number Numéro de Commande Номер товара	Menge Amount Quantité Количество	Beschreibung	Description	Description	Описание
120		01.10.10025	4,000	SKT-SCHRAUBE M10X25 8.8	SCREW M10X25 DIN 933	SCREW M10X25 DIN 933	
130		07.02.14	4,000	NORD-LOCK-SCHEIBE FUER M14	NORD-LOCK-DISC FOR M14	NORD-LOCK-DISC FOR M14	
140		07.02.12	4,000	NORD-LOCK-SCHEIBE FUER M12	NORD-LOCK-DISC FOR M12	NORD-LOCK-DISC FOR M12	
150		01.10.14055.C.V	4,000	SKT-SCHRAUBE M14X55 10.9	SKT-SCHRAUBE M14X55 10.9	SKT-SCHRAUBE M14X55 10.9	

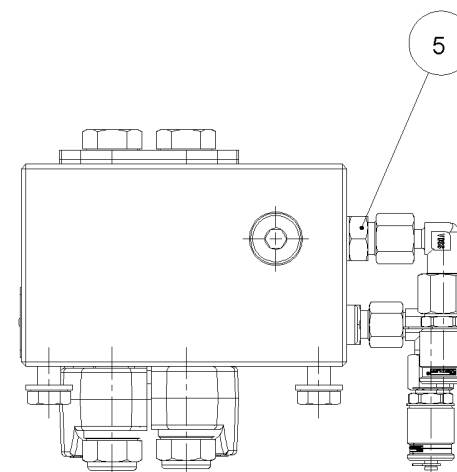
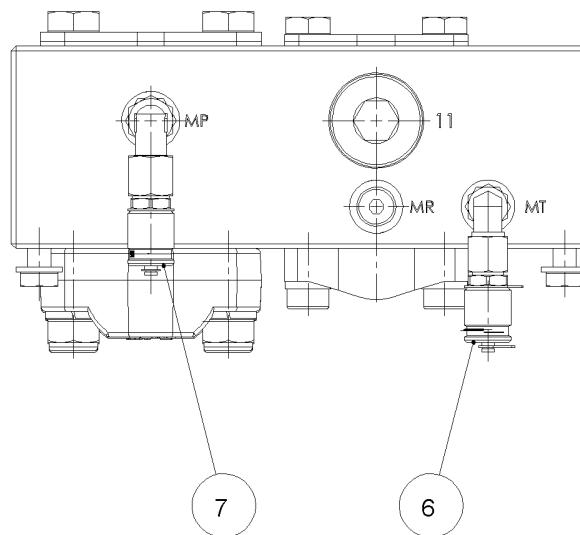
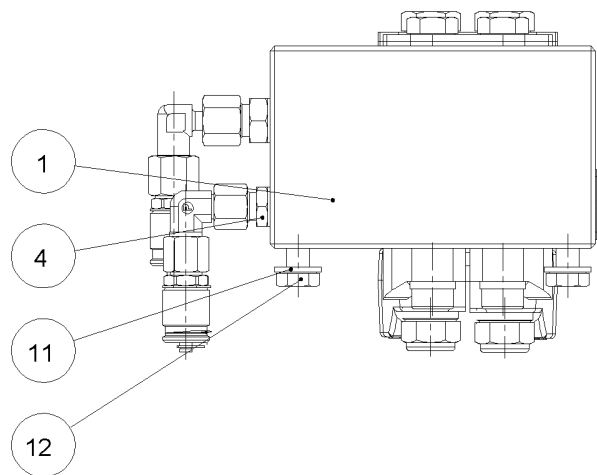
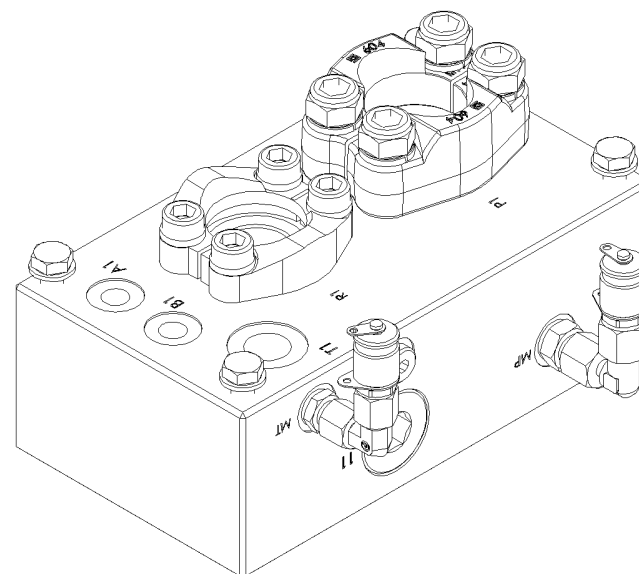
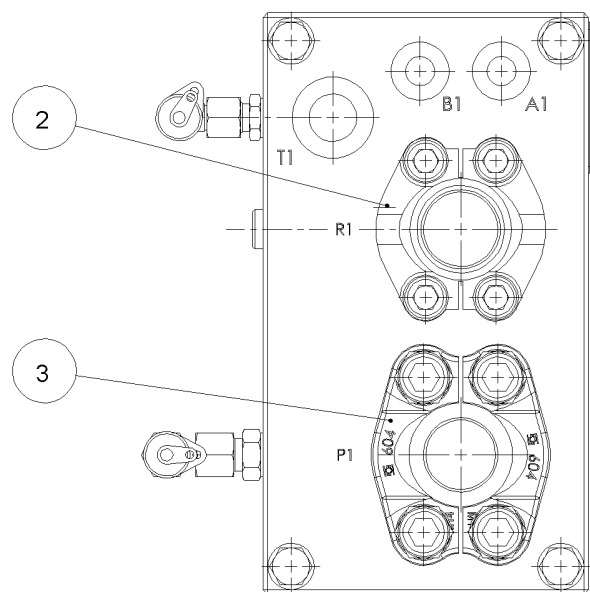

Pos.		Bestell-Nr. Stock Number Numéro de Commande Номер товара	Menge Amount Quantité Количество	Beschreibung	Description	Description	Описание
10		20.60.045/A	1,000	ANSCHLUSSBLOCK	ANSCHLUSSBLOCK	ANSCHLUSSBLOCK	
20		20.29.002/00	1,000	SAE-HALBFLANSCH 1 1/4 3000 PSI M12	SAE-HALF FLANGE 1 1/4"	SAE-HALF FLANGE 1 1/4"	
30		20.29.005/A	1,000	SAE-HALBFLANSCH 1 1/4 6000 PSI	SAE-HALBFLANSCH 1 1/4 6000 PSI	SAE-HALBFLANSCH 1 1/4 6000 PSI	
40		20.GEV08L.M12-1.5/00	1,000	GER-EINSCHR-VERSCHR. 8L	MALE STUD COUPLING 08L M12-1.5	MALE STUD COUPLING 08L M12-1.5	
50		20.GEV08S.M14-1.5/00	1,000	GER-EINSCHR-VERSCHR. 8S	STRAIGHT SCREW FITT. 8S 14X1,5	STRAIGHT SCREW FITT. 8S 14X1,5	
60		20.41.001/00	1,000	PRUEFANSCHLUSS MINIMESS 8L SMK 20	FITTING MEASUREMENT 8L/ SMK20	FITTING MEASUREMENT 8L/ SMK20	
70		20.41.002/00	1,000	PRUEFANSCHLUSS MINIMESS 8S SMK 20	PRUEFANSCHLUSS MINIMESS 8S SMK 20	PRUEFANSCHLUSS MINIMESS 8S SMK 20	
80		20.EWV08L/00	1,000	EINSTELLBARE-VERSCHR. EW 8L PN500	HYDR. FITTING EWV 8L	HYDR. FITTING EWV 8L	
90		20.EWV08S	1,000	EINSTELLBARE-VERSCHR. EW 8S PN800	HYDR. FITTING EWV 8S	HYDR. FITTING EWV 8S	
100		20.VS12.1.5/00	1,000	VERSCHLUSSSCHRAUBE M12X1,5 PN400, I-SW6	LOCK SCREW M12X1,5	LOCK SCREW M12X1,5	
110		05.01.10	4,000	SCHEIBE ISO 7090-10-200HV	WASHER B10,5 DIN 125 GALV.	WASHER B10,5 DIN 125 GALV.	



Pos.		Bestell-Nr. Stock Number Numéro de Commande Номер товара	Menge Amount Quantité Количество	Beschreibung	Description	Description	Описание
120		01.10.10025	4,000	SKT-SCHRAUBE M10X25 8.8	SCREW M10X25 DIN 933	SCREW M10X25 DIN 933	
130		07.02.14	4,000	NORD-LOCK-SCHEIBE FUER M14	NORD-LOCK-DISC FOR M14	NORD-LOCK-DISC FOR M14	
140		07.02.12	4,000	NORD-LOCK-SCHEIBE FUER M12	NORD-LOCK-DISC FOR M12	NORD-LOCK-DISC FOR M12	
150		01.10.14055.C.V	4,000	SKT-SCHRAUBE M14X55 10.9	SKT-SCHRAUBE M14X55 10.9	SKT-SCHRAUBE M14X55 10.9	

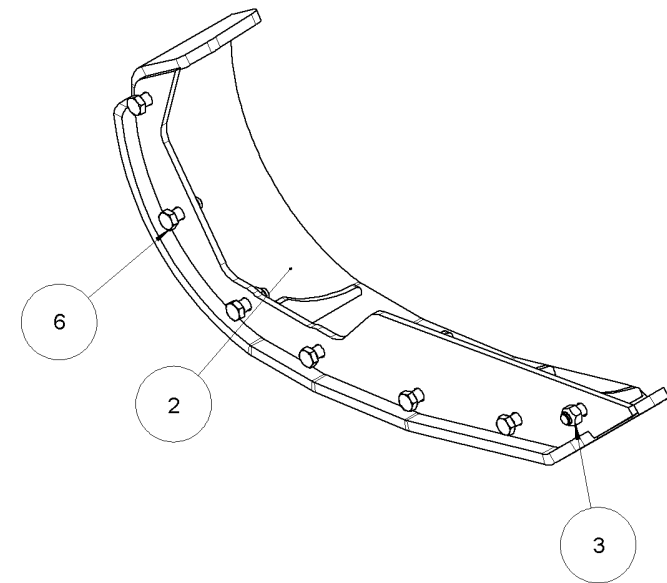
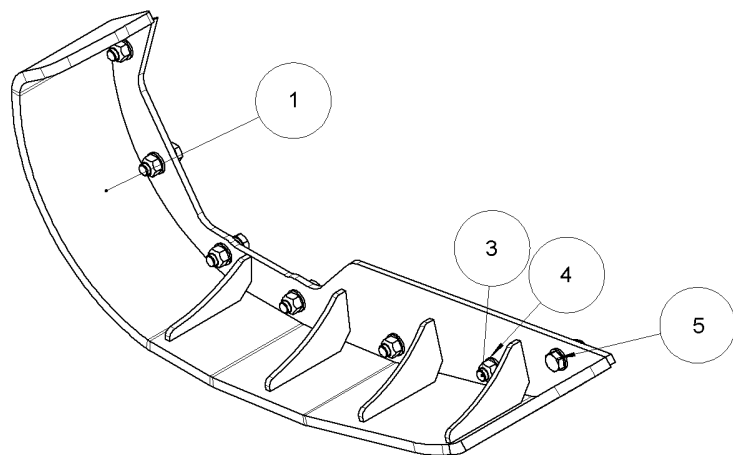

STANDARDKUFEN SATZ M550 - STANDARD SKIDS
STANDARD SKIDS - 550.06.00.00.00/B

550.06.00.00.00/B
Stücklistennummer / Piece Number / Liste de Pièces / Номер



Pos.		Bestell-Nr. Stock Number Numéro de Commande Номер товара	Menge Amount Quantité Количество	Beschreibung	Description	Description	Описание
10		550.06.00.20.00/01	1,000	KUFE-LINKS	RUNNER-LEFT	COUREUR-GAUCHE	
20		550.06.00.21.00/01	1,000	KUFE-RECHTS	RUNNER-RIGHT	COUREUR-DROITE	
30		03.02.16	14,0- 00	SKT-MUTTER M16 8, SELBSTSICH.	NUT M16 DIN980V SELF- LOCKING	NUT M16 DIN980V SELF- LOCKING	
40		05.01.17	14,0- 00	SCHEIBE ISO 7090-17-200HV	WASHER B17 DIN 125 GALVANIZED	WASHER B17 DIN 125 GALVANIZED	
50		01.10.16045	2,000	SKT-SCHRAUBE M16X45 8.8	SCREW M16X45 DIN 933	SCREW M16X45 DIN 933	
60		01.10.16050	12,0- 00	SKT-SCHRAUBE M16X50 8.8	HEX. SCREW M16X50 DIN933	HEX. SCREW M16X50 DIN933	

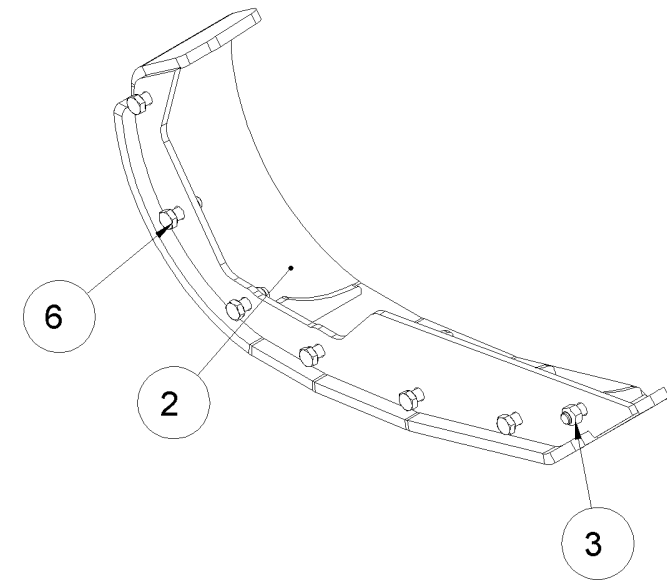
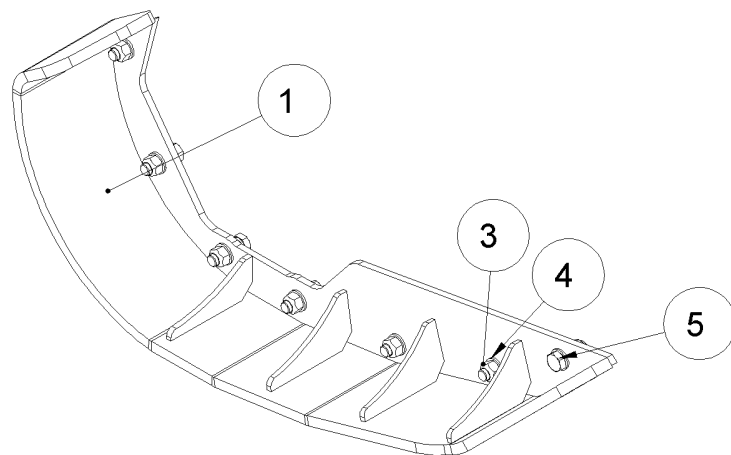

STANDARDKUFEN SATZ M550 - STANDARD SKIDS
STANDARD SKIDS - 550.06.00.00.00/B

550.06.00.00.00/B
Stücklistennummer / Piece Number / Liste de Pièces / Номер





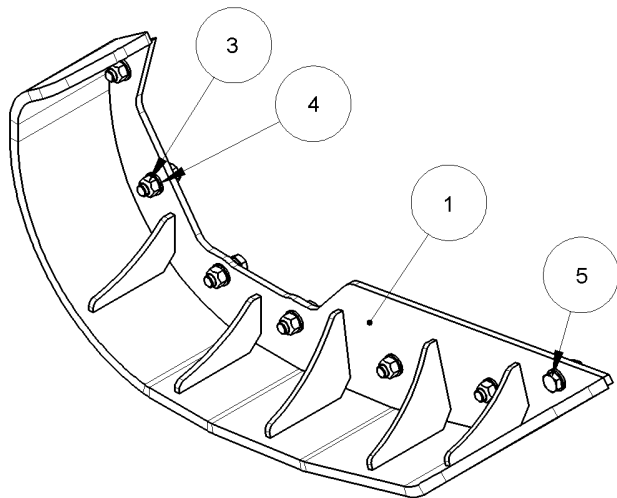
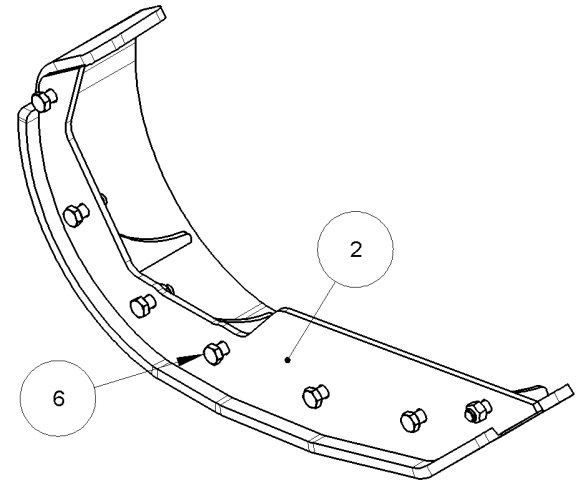



Pos.		Bestell-Nr. Stock Number Numéro de Commande Номер товара	Menge Amount Quantité Количество	Beschreibung	Description	Description	Описание
10		550.06.00.20.00/01	1,000	KUFE-LINKS	RUNNER-LEFT	COUREUR-GAUCHE	
20		550.06.00.21.00/01	1,000	KUFE-RECHTS	RUNNER-RIGHT	COUREUR-DROITE	
30		03.02.16	14,0- 00	SKT-MUTTER M16 8, SELBSTSICH.	NUT M16 DIN980V SELF- LOCKING	NUT M16 DIN980V SELF- LOCKING	
40		05.01.17	14,0- 00	SCHEIBE ISO 7090-17-200HV	WASHER B17 DIN 125 GALVANIZED	WASHER B17 DIN 125 GALVANIZED	
50		01.10.16045	2,000	SKT-SCHRAUBE M16X45 8.8	SCREW M16X45 DIN 933	SCREW M16X45 DIN 933	
60		01.10.16050	12,0- 00	SKT-SCHRAUBE M16X50 8.8	HEX. SCREW M16X50 DIN933	HEX. SCREW M16X50 DIN933	



HOCHKUFEN SATZ M550 - HIGH SKIDS
HIGH SKIDS - 550.06.00.01.00/00

550.06.00.01.00/00
Stücklistennummer / Piece Number / Liste de Pièces / Номер



Pos.		Bestell-Nr. Stock Number Numéro de Commande Номер товара	Menge Amount Quantité Количество	Beschreibung	Description	Description	Описание
10		550.06.00.24.00/00	1,000	KUFE LINKS	KUFE LINKS	KUFE LINKS	
20		550.06.00.25.00/00	1,000	KUFE RECHTS	KUFE RECHTS	KUFE RECHTS	
30		03.02.16	14,0- 00	SKT-MUTTER M16 8, SELBSTSICH.	NUT M16 DIN980V SELF- LOCKING	NUT M16 DIN980V SELF- LOCKING	
40		05.01.17	14,0- 00	SCHEIBE ISO 7090-17-200HV	WASHER B17 DIN 125 GALVANIZED	WASHER B17 DIN 125 GALVANIZED	
50		01.10.16045	2,000	SKT-SCHRAUBE M16X45 8.8	SCREW M16X45 DIN 933	SCREW M16X45 DIN 933	
60		01.10.16050	12,0- 00	SKT-SCHRAUBE M16X50 8.8	HEX. SCREW M16X50 DIN933	HEX. SCREW M16X50 DIN933	

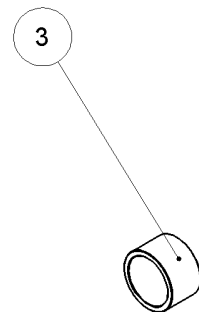
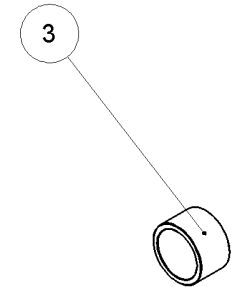
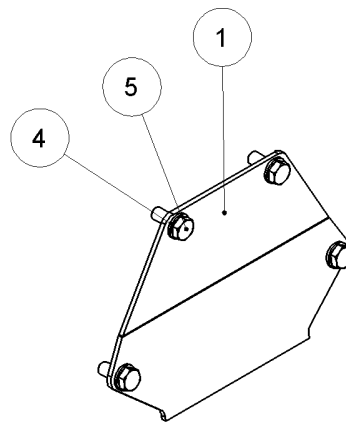
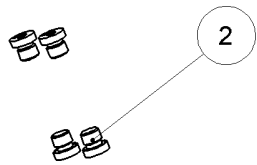

DECKEL WENN OHNE Klappe - DECKEL WENN OHNE Klappe
 DECKEL WENN OHNE Klappe - 560.10.03.00.00/00

560.10.03.00.00/00
 Stücklistennummer / Piece Number / Liste de Pièces / Номер



Pos.		Bestell-Nr. Stock Number Numéro de Commande Номер товара	Menge Amount Quantité Количество	Beschreibung	Description	Description	Описание
10		560.10.03.00.01/00	1,000	BLECH	BLECH	BLECH	
20		20.VS14.1.5/00	4,000	VERSCHLUSSSCHRAUBE M14X1,5 PN400, I-SW6	LOCK SCREW M14X1,5	LOCK SCREW M14X1,5	
30		451.10.05.00.01/00	2,000	HUELSE	HUELSE	HUELSE	
40		05.01.10	4,000	SCHEIBE ISO 7090-10-200HV	WASHER B10,5 DIN 125 GALV.	WASHER B10,5 DIN 125 GALV.	
50		01.10.10025	4,000	SKT-SCHRAUBE M10X25 8.8	SCREW M10X25 DIN 933	SCREW M10X25 DIN 933	

KLAPPE MIT GEGENSCHNEIDE M550E - FLAP W. COUNTER BLADES
FLAP W. COUNTER BLADES - 560.10.00.01.00/00

560.10.00.01.00/00









Stücklistennummer / Piece Number / Liste de Pièces / Homep

Pinath[®]

KLAPPE MIT GEGENSCHNEIDE M550E - FLAP W. COUNTER BLADES
 FLAP W. COUNTER BLADES - 560.10.00.01.00/00

560.10.00.01.00/00
 Stücklistennummer / Piece Number / Liste de Pièces / Homep



Pos.	Bestell-Nr. Stock Number Numéro de Commande Номер товара	Menge Amount Quantité Количество	Beschreibung	Description	Description	Описание
10	 560.10.00.20.00/00	1,000	<u>KLAPPE GESCHWEISST</u>	KLAPPE GESCHWEISST	KLAPPE GESCHWEISST	
20	 560.10.00.22.00/00	2,000	<u>GEGENSCHNEIDE GESCHWEISST - FUER Klappe</u>	GEGENSCHNEIDE GESCHWEISST - FUER Klappe	GEGENSCHNEIDE GESCHWEISST - FUER Klappe	
30	 551.10.01.01.00/A	1,000	<u>BOLZEN MIT SCHRAUBE</u>	BOLZEN MIT SCHRAUBE	BOLZEN MIT SCHRAUBE	
40	 551.10.01.01.00/A	1,000	<u>BOLZEN MIT SCHRAUBE</u>	BOLZEN MIT SCHRAUBE	BOLZEN MIT SCHRAUBE	
50	 12.40.44.30/00	2,000	GLEITBUCHSE	SLIDE BUSHING	DOUILLE DE GLISSEMENT	
60	 991.10.42.00.00/00	1,000	HYDRAULIK-ZYLINDER	HYDRAULIK-ZYLINDER	HYDRAULIK-ZYLINDER	
70	 05.04.13	10,0- 00	SCHEIBE B13	WASHER B13 DIN 7349 GALVANIZED	WASHER B13 DIN 7349 GALVANIZED	
80	 03.02.12	10,0- 00	SKT-MUTTER M12 8, SELBSTSICH.	NUT M12 DIN980V SELF- LOCKING	NUT M12 DIN980V SELF- LOCKING	
90	01.10.12030	10,0- 00	SKT-SCHRAUBE M12X30 8.8	SCREW M12X30 DIN 933	SCREW M12X30 DIN 933	

1

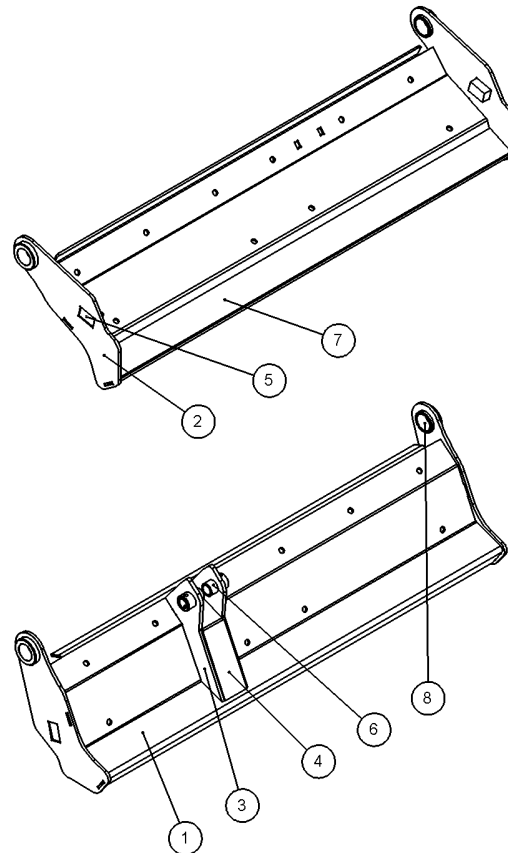

KLAPPE GESCHWEISST - Klappe geschweisst
KLAPPE GESCHWEISST - 560.10.00.20.00/00

560.10.00.20.00/00
Stücklistennummer / Piece Number / Liste de Pièces / Номер



Pos.	Bestell-Nr. Stock Number Numéro de Commande Номер товара	Menge Amount Quantité Количество	Beschreibung	Description	Description	Описание
------	---	---	--------------	-------------	-------------	----------

80	 742.10.01.00.04/00	2,000	BUCHSE	BUSHING	BUSHING	
----	--	-------	--------	---------	---------	--

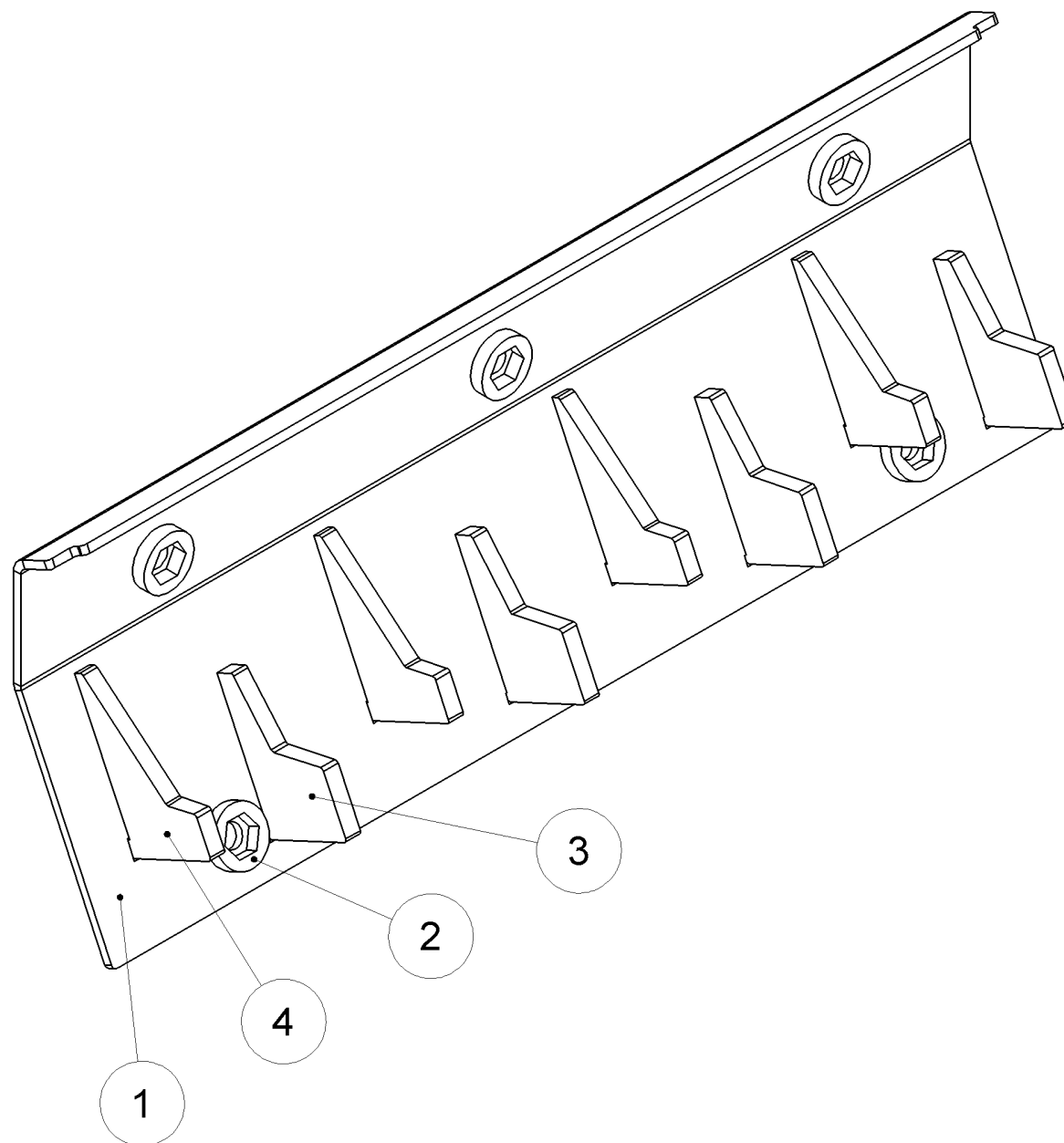



Pos.	Bestell-Nr. Stock Number Numéro de Commande Номер товара	Menge Amount Quantité Количество	Beschreibung	Description	Description	Описание
------	---	---	--------------	-------------	-------------	----------

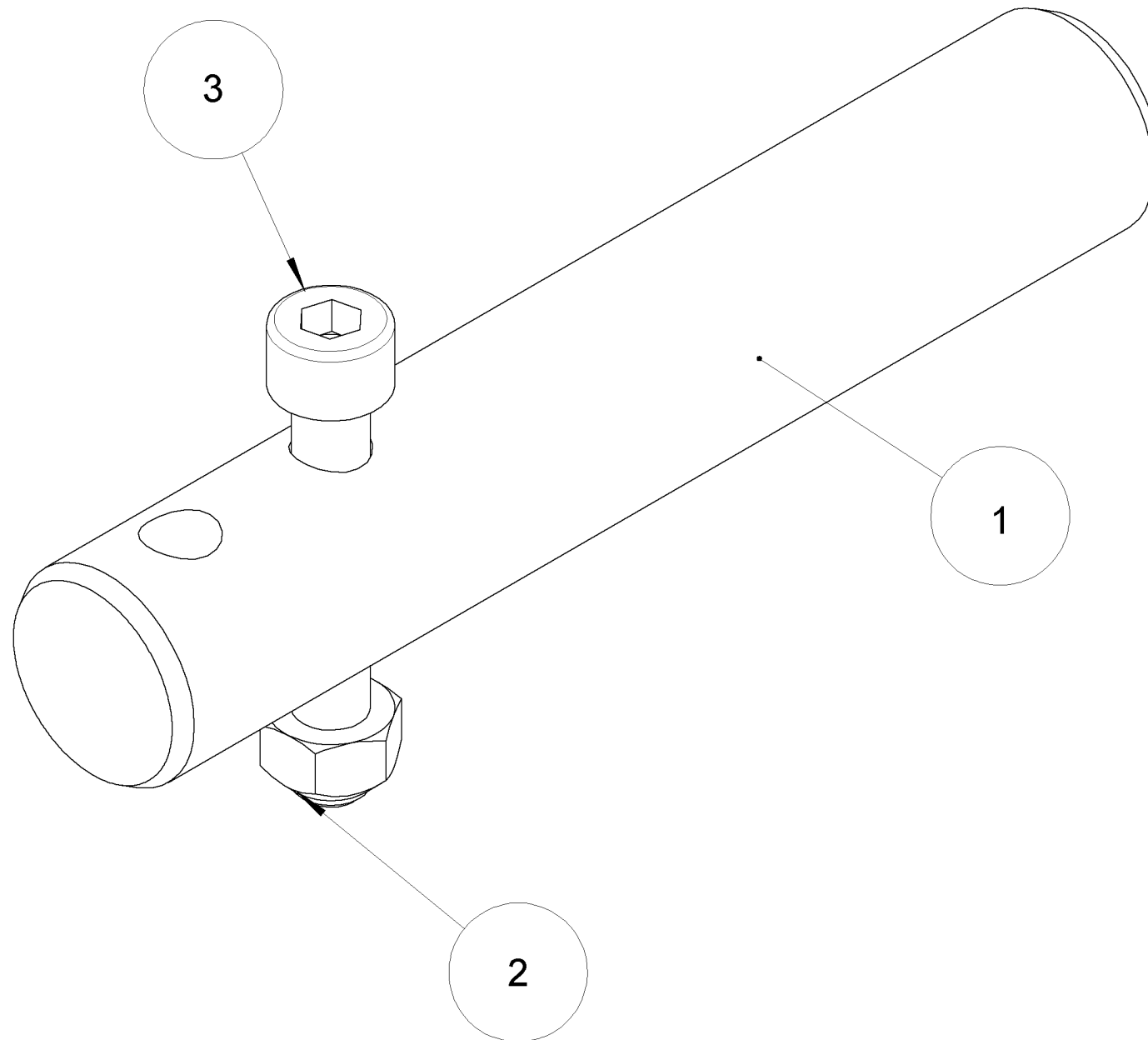

40	650.10.01.20.03/00	4,000	GEGENSCHNEIDE	GEGENSCHNEIDE	GEGENSCHNEIDE	
----	--------------------	-------	---------------	---------------	---------------	--



BOLZEN MIT SCHRAUBE - BOLZEN MIT SCHRAUBE
 BOLZEN MIT SCHRAUBE - 551.10.01.01.00/A

551.10.01.01.00/A
 Stücklistennummer / Piece Number / Liste de Pièces / Номер



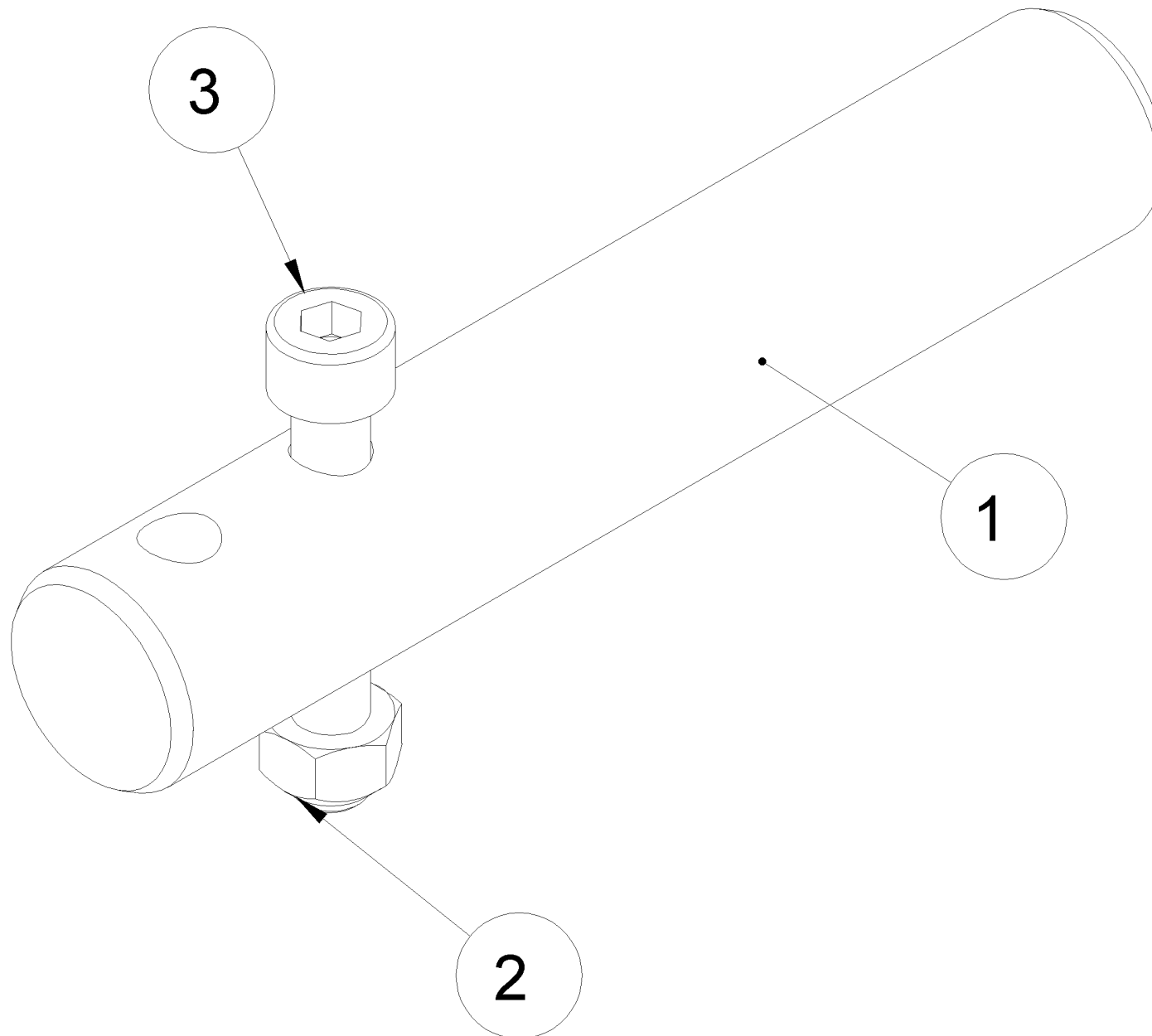

Pos.	Bestell-Nr. Stock Number Numéro de Commande Номер товара	Menge Amount Quantité Количество	Beschreibung	Description	Description	Описание
10	 551.10.01.01.01/A	1,000	BOLZEN MIT BOHRUNG	BOLZEN MIT BOHRUNG	BOLZEN MIT BOHRUNG	
20	 03.02.08	1,000	SKT-MUTTER M8 8, SELBSTSICH.	NUT M8 DIN980V SELF-LOCKING	NUT M8 DIN980V SELF-LOCKING	
30	 01.20.08050	1,000	ZYLINDERSCHRAUBE M8X50 8.8	CYL. HEAD SCREW M8X50 DIN 912	CYL. HEAD SCREW M8X50 DIN 912	



BOLZEN MIT SCHRAUBE - BOLZEN MIT SCHRAUBE
 BOLZEN MIT SCHRAUBE - 551.10.01.01.00/A

551.10.01.01.00/A
 Stücklistennummer / Piece Number / Liste de Pièces / Номер



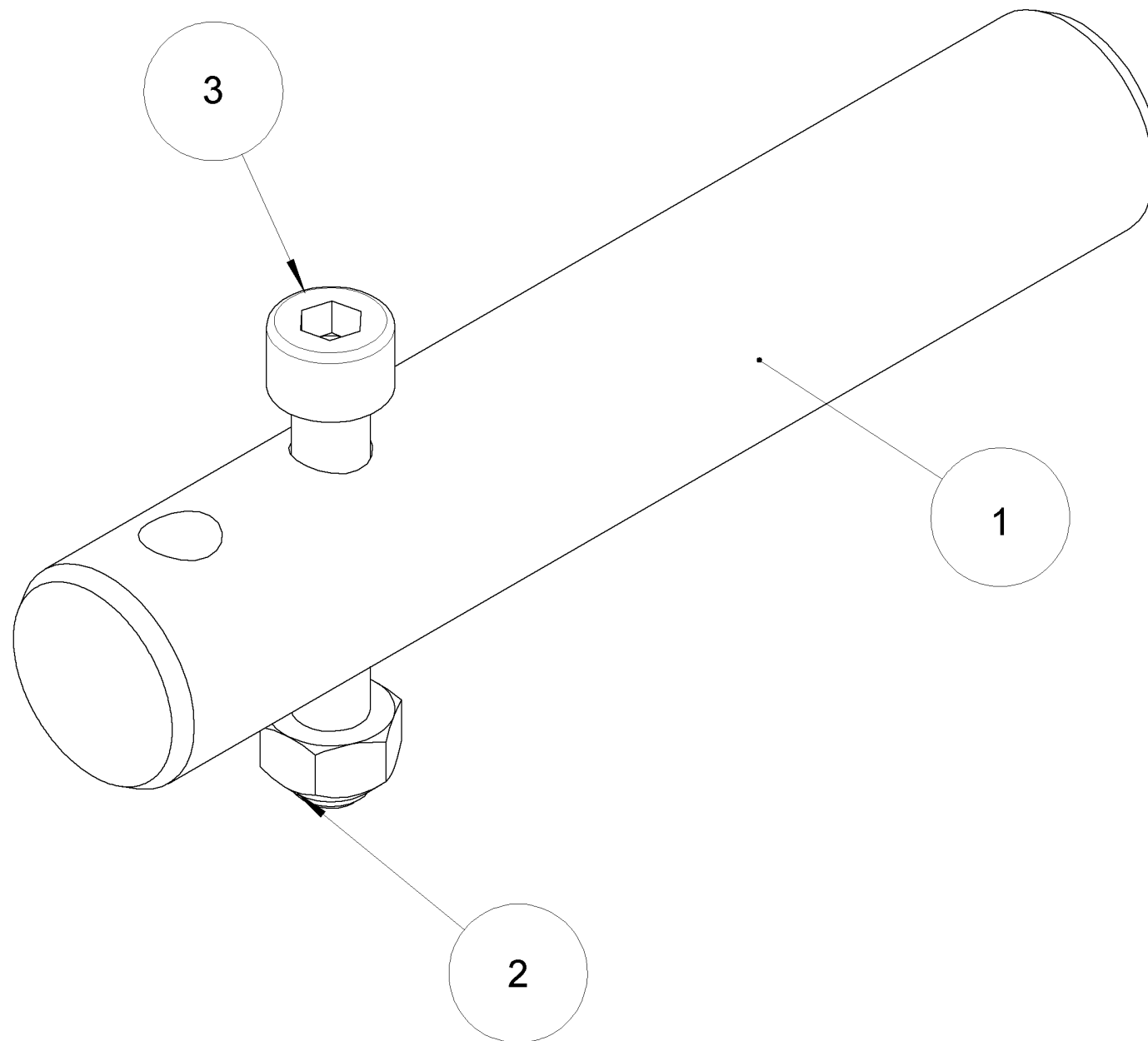

Pos.	Bestell-Nr. Stock Number Numéro de Commande Номер товара	Menge Amount Quantité Количество	Beschreibung	Description	Description	Описание
10	 551.10.01.01.01/A	1,000	BOLZEN MIT BOHRUNG	BOLZEN MIT BOHRUNG	BOLZEN MIT BOHRUNG	
20	 03.02.08	1,000	SKT-MUTTER M8 8, SELBSTSICH.	NUT M8 DIN980V SELF-LOCKING	NUT M8 DIN980V SELF-LOCKING	
30	 01.20.08050	1,000	ZYLINDERSCHRAUBE M8X50 8.8	CYL. HEAD SCREW M8X50 DIN 912	CYL. HEAD SCREW M8X50 DIN 912	



BOLZEN MIT SCHRAUBE - BOLZEN MIT SCHRAUBE
 BOLZEN MIT SCHRAUBE - 551.10.01.01.00/A

551.10.01.01.00/A
 Stücklistennummer / Piece Number / Liste de Pièces / Номер



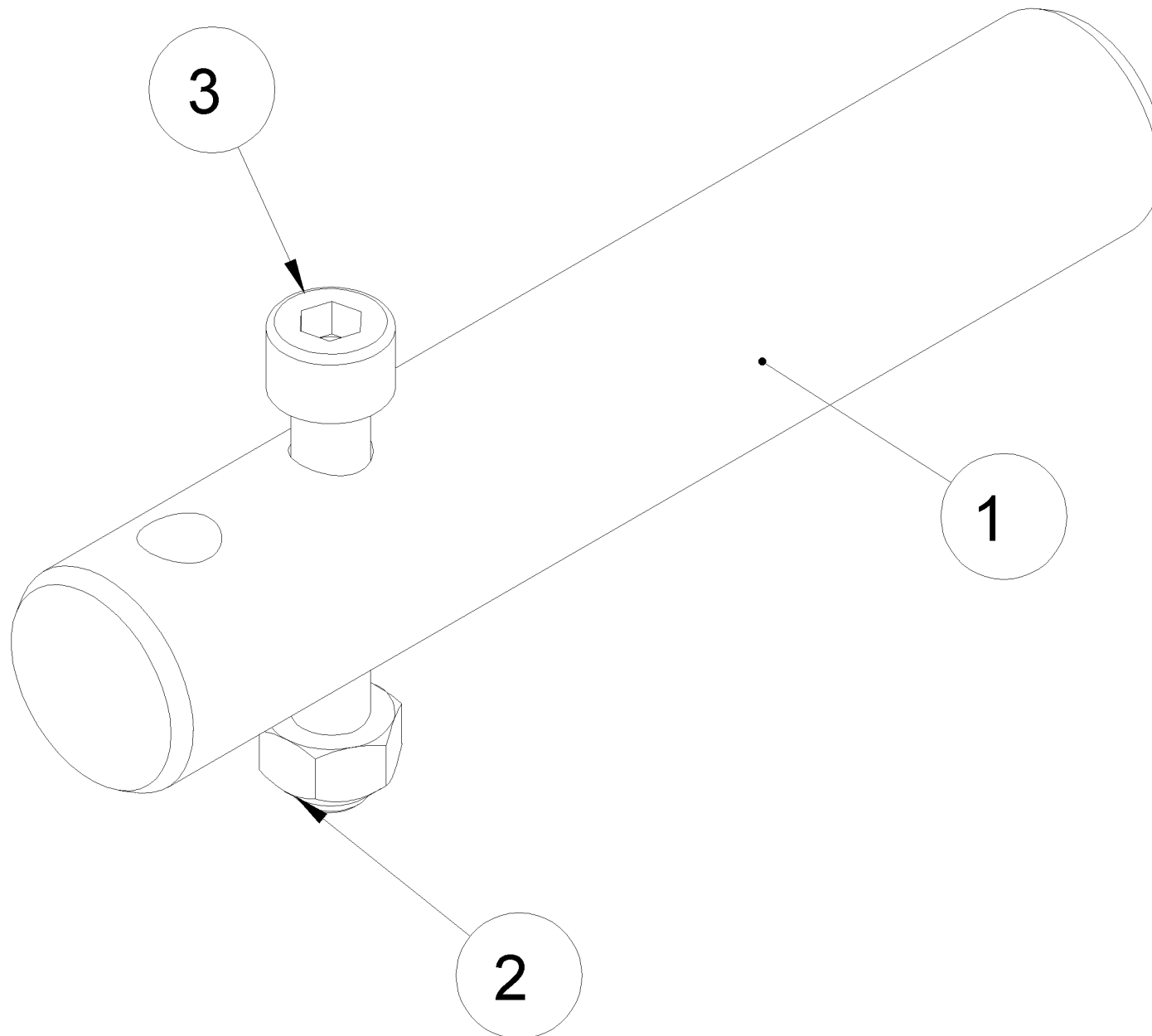

Pos.	Bestell-Nr. Stock Number Numéro de Commande Номер товара	Menge Amount Quantité Количество	Beschreibung	Description	Description	Описание
10	 551.10.01.01.01/A	1,000	BOLZEN MIT BOHRUNG	BOLZEN MIT BOHRUNG	BOLZEN MIT BOHRUNG	
20	 03.02.08	1,000	SKT-MUTTER M8 8, SELBSTSICH.	NUT M8 DIN980V SELF-LOCKING	NUT M8 DIN980V SELF-LOCKING	
30	 01.20.08050	1,000	ZYLINDERSCHRAUBE M8X50 8.8	CYL. HEAD SCREW M8X50 DIN 912	CYL. HEAD SCREW M8X50 DIN 912	



BOLZEN MIT SCHRAUBE - BOLZEN MIT SCHRAUBE
 BOLZEN MIT SCHRAUBE - 551.10.01.01.00/A

551.10.01.01.00/A
 Stücklistennummer / Piece Number / Liste de Pièces / Номер





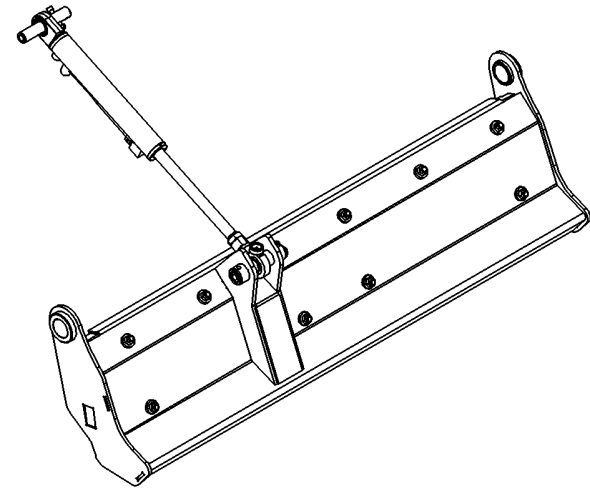
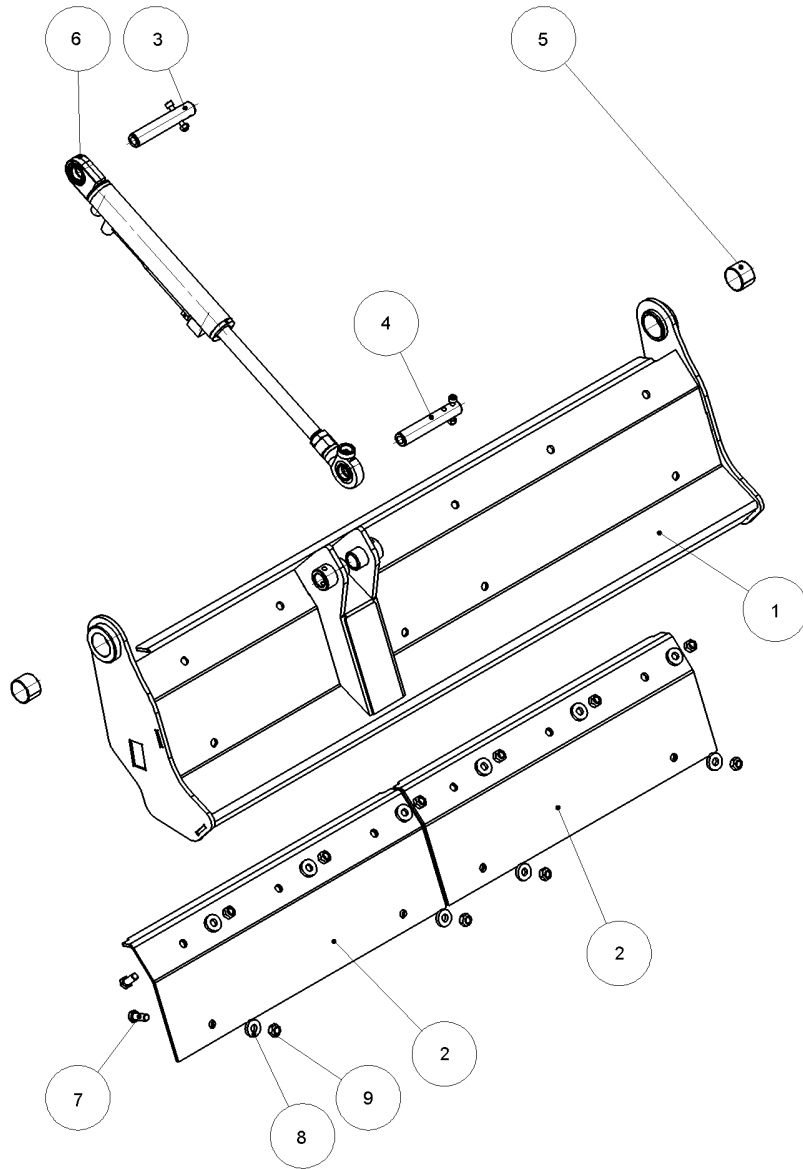





Pos.	Bestell-Nr. Stock Number Numéro de Commande Номер товара	Menge Amount Quantité Количество	Beschreibung	Description	Description	Описание
10	 551.10.01.01.01/A	1,000	BOLZEN MIT BOHRUNG	BOLZEN MIT BOHRUNG	BOLZEN MIT BOHRUNG	
20	 03.02.08	1,000	SKT-MUTTER M8 8, SELBSTSICH.	NUT M8 DIN980V SELF-LOCKING	NUT M8 DIN980V SELF-LOCKING	
30	 01.20.08050	1,000	ZYLINDERSCHRAUBE M8X50 8.8	CYL. HEAD SCREW M8X50 DIN 912	CYL. HEAD SCREW M8X50 DIN 912	



KLAPPE OHNE GEGENSCHNEIDE M550E - FLAP W/O COUNTER BLADES
 FLAP W/O COUNTER BLADES - 560.10.00.00.00/00

560.10.00.00.00/00
 Stücklistennummer / Piece Number / Liste de Pièces / Homep



Pos.	Bestell-Nr. Stock Number Numéro de Commande Номер товара	Menge Amount Quantité Количество	Beschreibung	Description	Description	Описание
10	 560.10.00.20.00/00	1,000	KLAPPE GESCHWEISST	KLAPPE GESCHWEISST	KLAPPE GESCHWEISST	
20	 560.10.00.21.00/00	2,000	VERSCHLEISSPLATTE	VERSCHLEISSPLATTE	VERSCHLEISSPLATTE	
30	 551.10.01.01.00/A	1,000	BOLZEN MIT SCHRAUBE	BOLZEN MIT SCHRAUBE	BOLZEN MIT SCHRAUBE	
40	 551.10.01.01.00/A	1,000	BOLZEN MIT SCHRAUBE	BOLZEN MIT SCHRAUBE	BOLZEN MIT SCHRAUBE	
50	 12.40.44.30/00	2,000	GLEITBUCHSE	SLIDE BUSHING	DOUILLE DE GLISSEMENT	
60	 991.10.42.00.00/00	1,000	HYDRAULIK-ZYLINDER	HYDRAULIK-ZYLINDER	HYDRAULIK-ZYLINDER	
70	01.10.12030	10,0-00	SKT-SCHRAUBE M12X30 8.8	SCREW M12X30 DIN 933	SCREW M12X30 DIN 933	
80	 05.04.13	10,0-00	SCHEIBE B13	WASHER B13 DIN 7349 GALVANIZED	WASHER B13 DIN 7349 GALVANIZED	
90	 03.02.12	10,0-00	SKT-MUTTER M12 8, SELBSTSICH.	NUT M12 DIN980V SELF-LOCKING	NUT M12 DIN980V SELF-LOCKING	

1

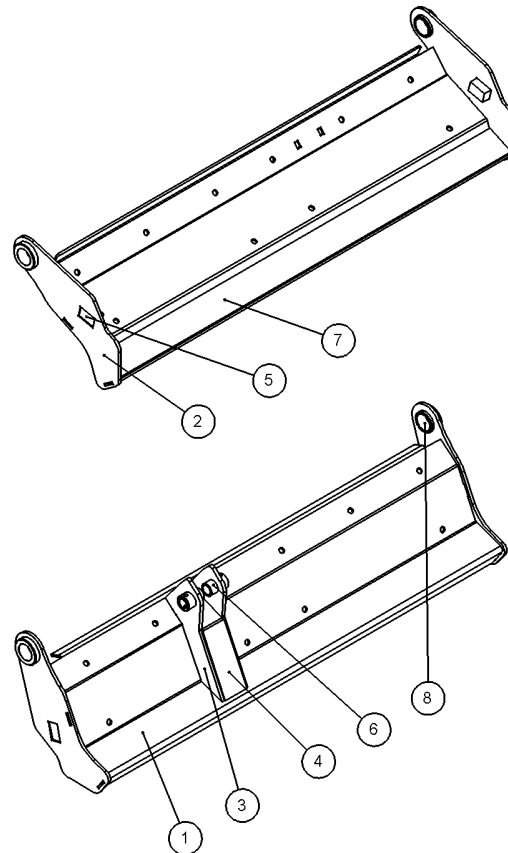

KLAPPE GESCHWEISST - Klappe geschweisst
KLAPPE GESCHWEISST - 560.10.00.20.00/00

560.10.00.20.00/00
Stücklistennummer / Piece Number / Liste de Pièces / Номер



Pos.	Bestell-Nr. Stock Number Numéro de Commande Номер товара	Menge Amount Quantité Количество	Beschreibung	Description	Description	Описание
------	---	---	--------------	-------------	-------------	----------

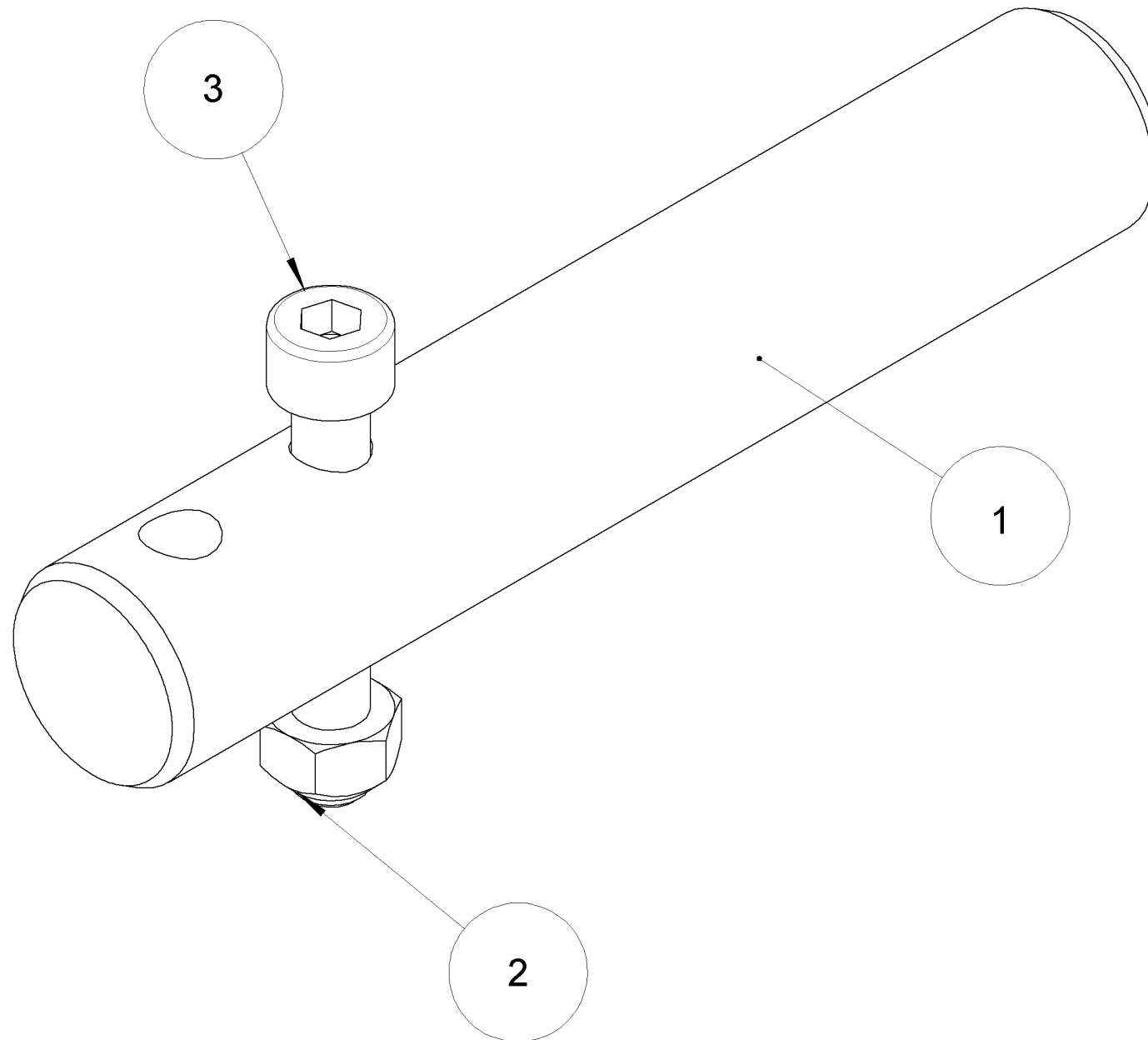

80	 742.10.01.00.04/00	2,000	BUCHSE	BUSHING	BUSHING	
----	--	-------	--------	---------	---------	--



BOLZEN MIT SCHRAUBE - BOLZEN MIT SCHRAUBE
 BOLZEN MIT SCHRAUBE - 551.10.01.01.00/A

551.10.01.01.00/A
 Stücklistennummer / Piece Number / Liste de Pièces / Номер



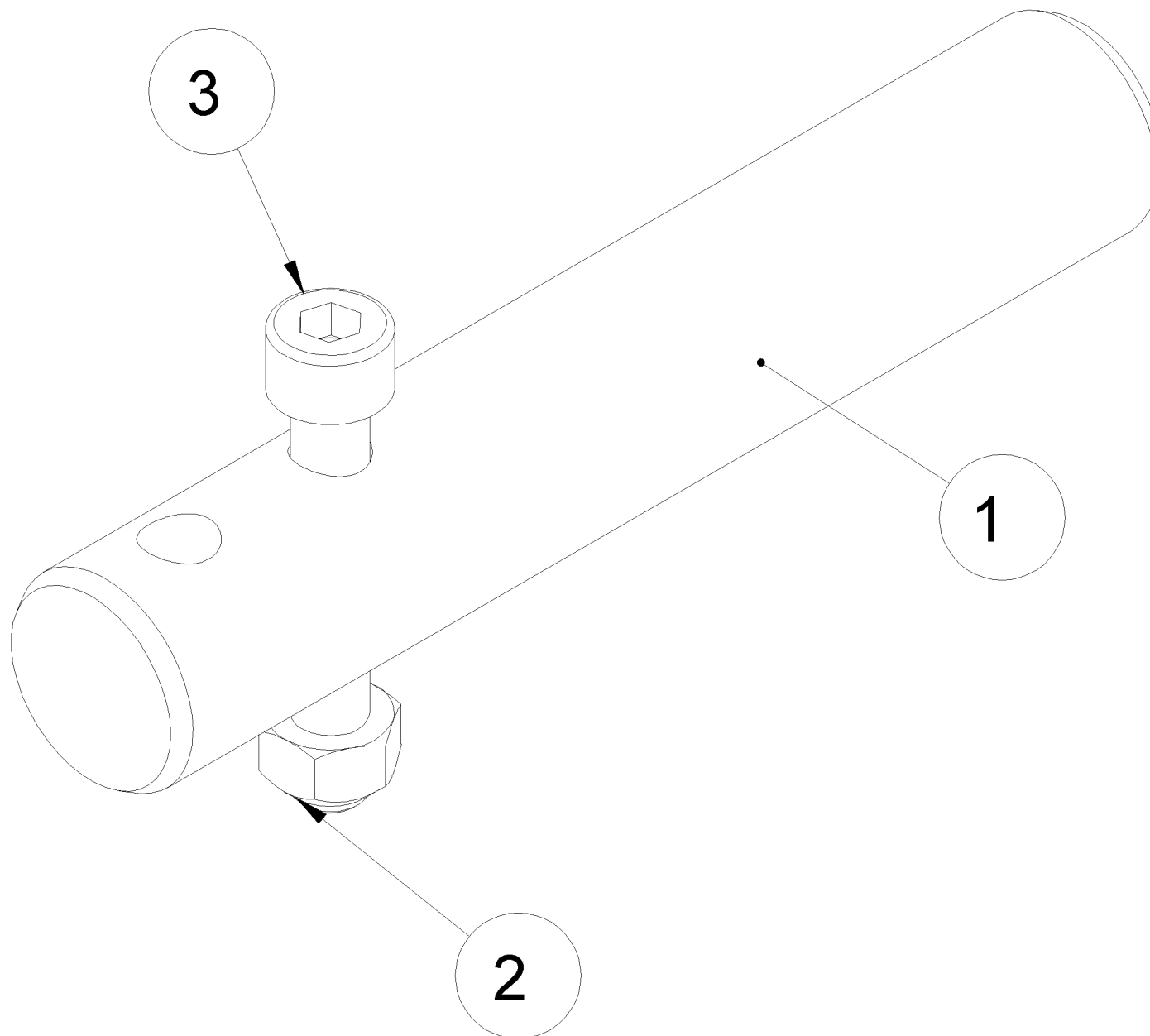

Pos.	Bestell-Nr. Stock Number Numéro de Commande Номер товара	Menge Amount Quantité Количество	Beschreibung	Description	Description	Описание
10	 551.10.01.01.01/A	1,000	BOLZEN MIT BOHRUNG	BOLZEN MIT BOHRUNG	BOLZEN MIT BOHRUNG	
20	 03.02.08	1,000	SKT-MUTTER M8 8, SELBSTSICH.	NUT M8 DIN980V SELF-LOCKING	NUT M8 DIN980V SELF-LOCKING	
30	 01.20.08050	1,000	ZYLINDERSCHRAUBE M8X50 8.8	CYL. HEAD SCREW M8X50 DIN 912	CYL. HEAD SCREW M8X50 DIN 912	



BOLZEN MIT SCHRAUBE - BOLZEN MIT SCHRAUBE
 BOLZEN MIT SCHRAUBE - 551.10.01.01.00/A

551.10.01.01.00/A
 Stücklistennummer / Piece Number / Liste de Pièces / Номер



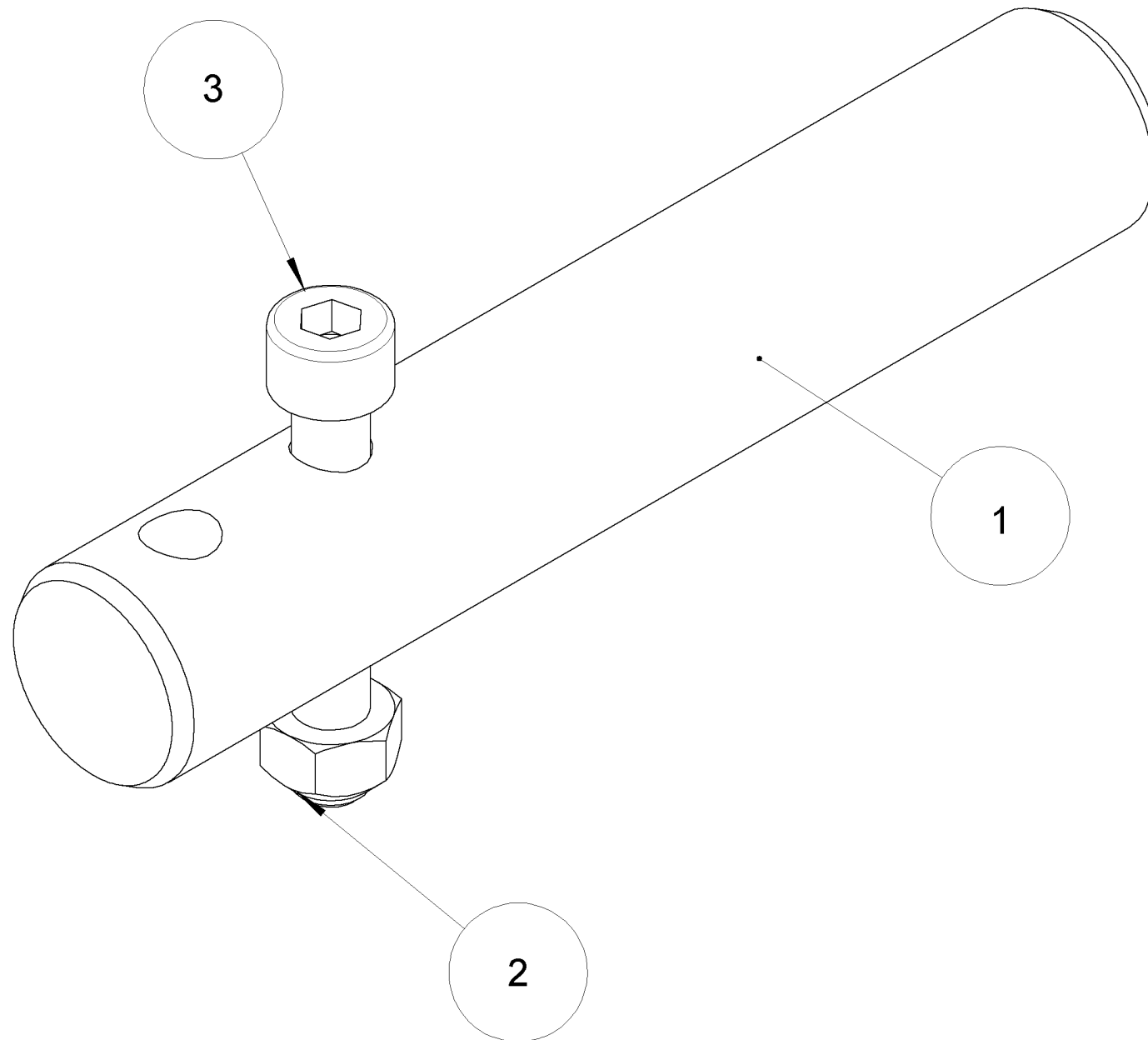

Pos.	Bestell-Nr. Stock Number Numéro de Commande Номер товара	Menge Amount Quantité Количество	Beschreibung	Description	Description	Описание
10	 551.10.01.01.01/A	1,000	BOLZEN MIT BOHRUNG	BOLZEN MIT BOHRUNG	BOLZEN MIT BOHRUNG	
20	 03.02.08	1,000	SKT-MUTTER M8 8, SELBSTSICH.	NUT M8 DIN980V SELF-LOCKING	NUT M8 DIN980V SELF-LOCKING	
30	 01.20.08050	1,000	ZYLINDERSCHRAUBE M8X50 8.8	CYL. HEAD SCREW M8X50 DIN 912	CYL. HEAD SCREW M8X50 DIN 912	



BOLZEN MIT SCHRAUBE - BOLZEN MIT SCHRAUBE
 BOLZEN MIT SCHRAUBE - 551.10.01.01.00/A

551.10.01.01.00/A
 Stücklistennummer / Piece Number / Liste de Pièces / Номер



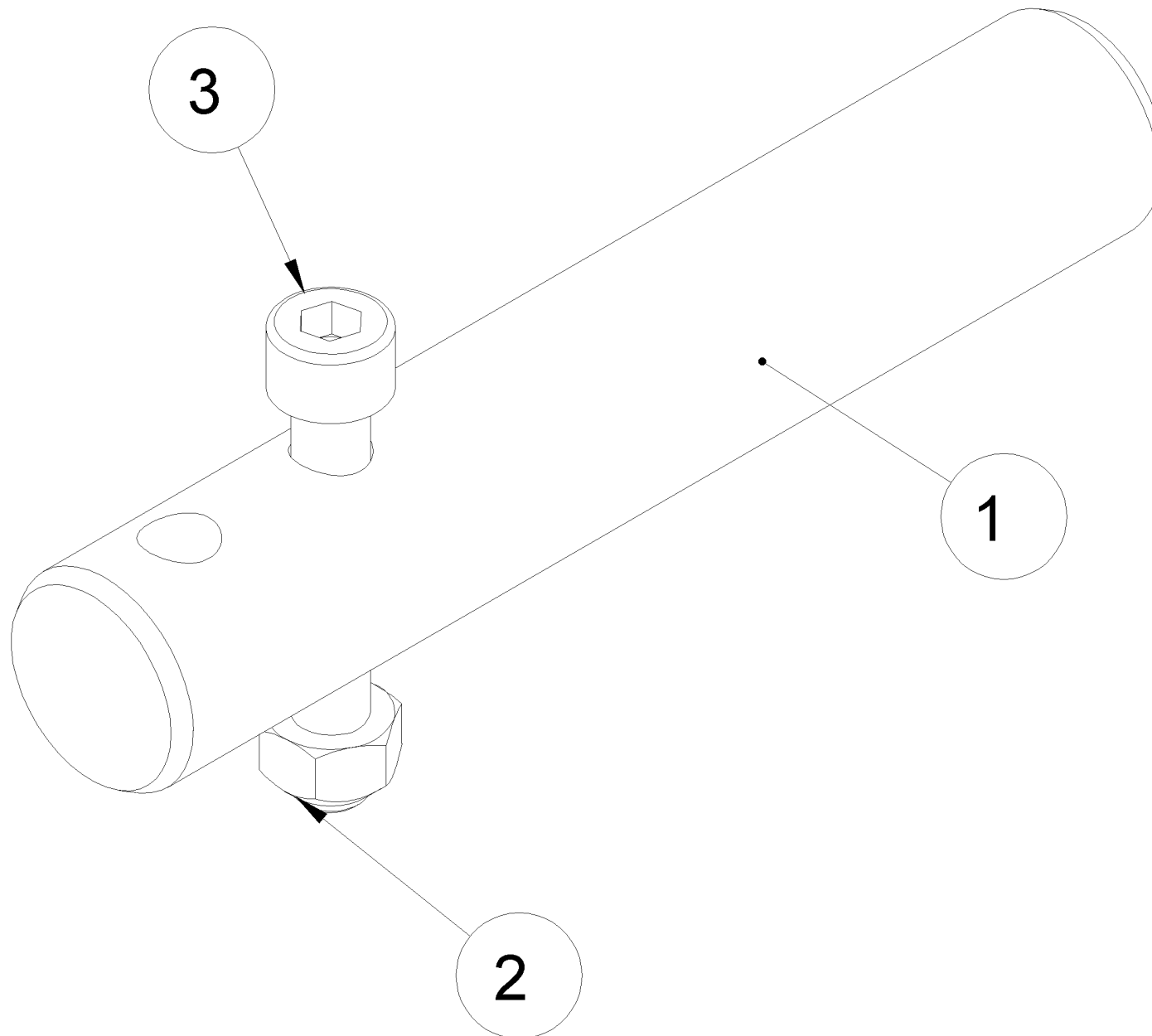

Pos.	Bestell-Nr. Stock Number Numéro de Commande Номер товара	Menge Amount Quantité Количество	Beschreibung	Description	Description	Описание
10	 551.10.01.01.01/A	1,000	BOLZEN MIT BOHRUNG	BOLZEN MIT BOHRUNG	BOLZEN MIT BOHRUNG	
20	 03.02.08	1,000	SKT-MUTTER M8 8, SELBSTSICH.	NUT M8 DIN980V SELF-LOCKING	NUT M8 DIN980V SELF-LOCKING	
30	 01.20.08050	1,000	ZYLINDERSCHRAUBE M8X50 8.8	CYL. HEAD SCREW M8X50 DIN 912	CYL. HEAD SCREW M8X50 DIN 912	



BOLZEN MIT SCHRAUBE - BOLZEN MIT SCHRAUBE
 BOLZEN MIT SCHRAUBE - 551.10.01.01.00/A

551.10.01.01.00/A
 Stücklistennummer / Piece Number / Liste de Pièces / Номер





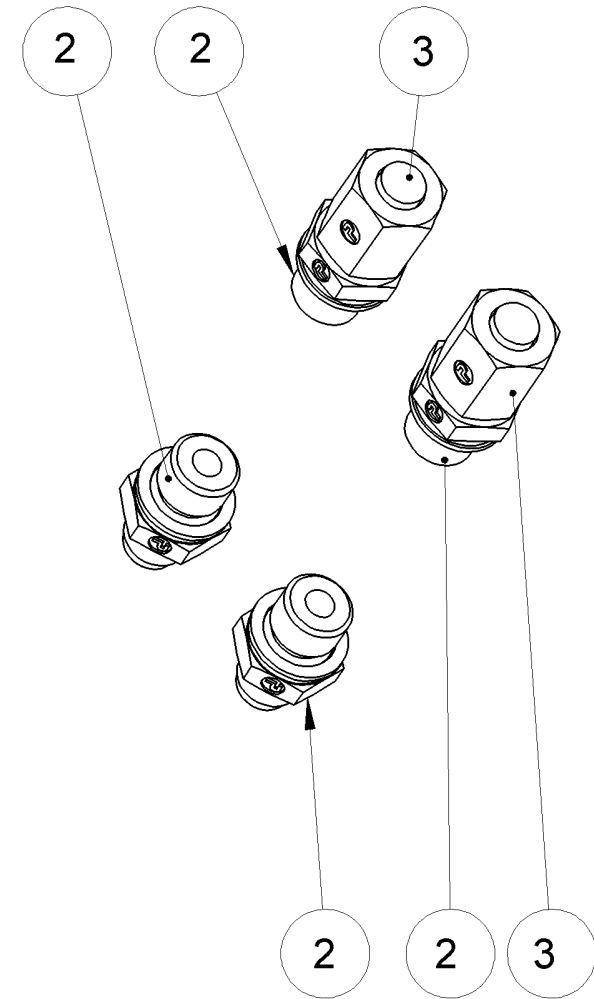
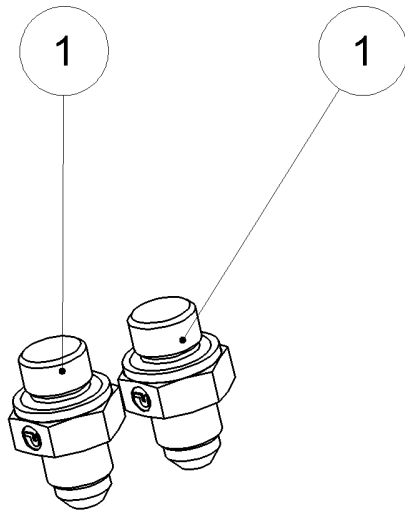

Pos.	Bestell-Nr. Stock Number Numéro de Commande Номер товара	Menge Amount Quantité Количество	Beschreibung	Description	Description	Описание
10	 551.10.01.01.01/A	1,000	BOLZEN MIT BOHRUNG	BOLZEN MIT BOHRUNG	BOLZEN MIT BOHRUNG	
20	 03.02.08	1,000	SKT-MUTTER M8 8, SELBSTSICH.	NUT M8 DIN980V SELF-LOCKING	NUT M8 DIN980V SELF-LOCKING	
30	 01.20.08050	1,000	ZYLINDERSCHRAUBE M8X50 8.8	CYL. HEAD SCREW M8X50 DIN 912	CYL. HEAD SCREW M8X50 DIN 912	



HYDRAULIK FUER Klappe JIC - HYDRAULICS JIC
 HYDRAULICS JIC - 560.15.00.01.00/A

560.15.00.01.00/A
 Stücklistennummer / Piece Number / Liste de Pièces / Номер



Pos.		Bestell-Nr. Stock Number Numéro de Commande Номер товара	Menge Amount Quantité Количество	Beschreibung	Description	Description	Описание
10		20.04.00030/00	2,000	EINSCHRAUBSTUTZEN JIC37	SCREW-IN FITTING JIC37	SCREW-IN FITTING JIC37	
20		20.04.00014/00	4,000	EINSCHRAUBSTUTZEN JIC37	EINSCHRAUBSTUTZEN JIC37	EINSCHRAUBSTUTZEN JIC37	
30		20.04.00021/00	2,000	VERSCHLUSSSTOPFEN JIC37 8 PN315 SW17	VERSCHLUSSSTOPFEN JIC37 8 PN315 SW17	VERSCHLUSSSTOPFEN JIC37 8 PN315 SW17	

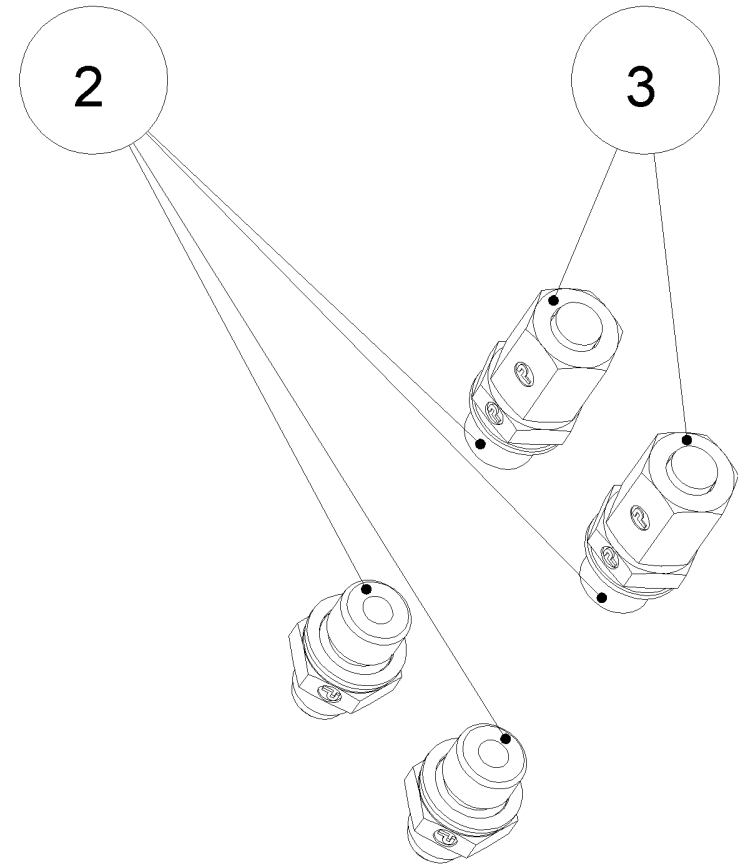
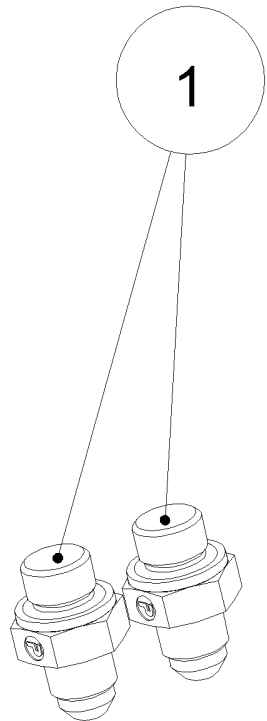

HYDRAULIK FUER Klappe JIC - HYDRAULICS JIC
 HYDRAULICS JIC - 560.15.00.01.00/A

560.15.00.01.00/A
 Stücklistennummer / Piece Number / Liste de Pièces / Номер





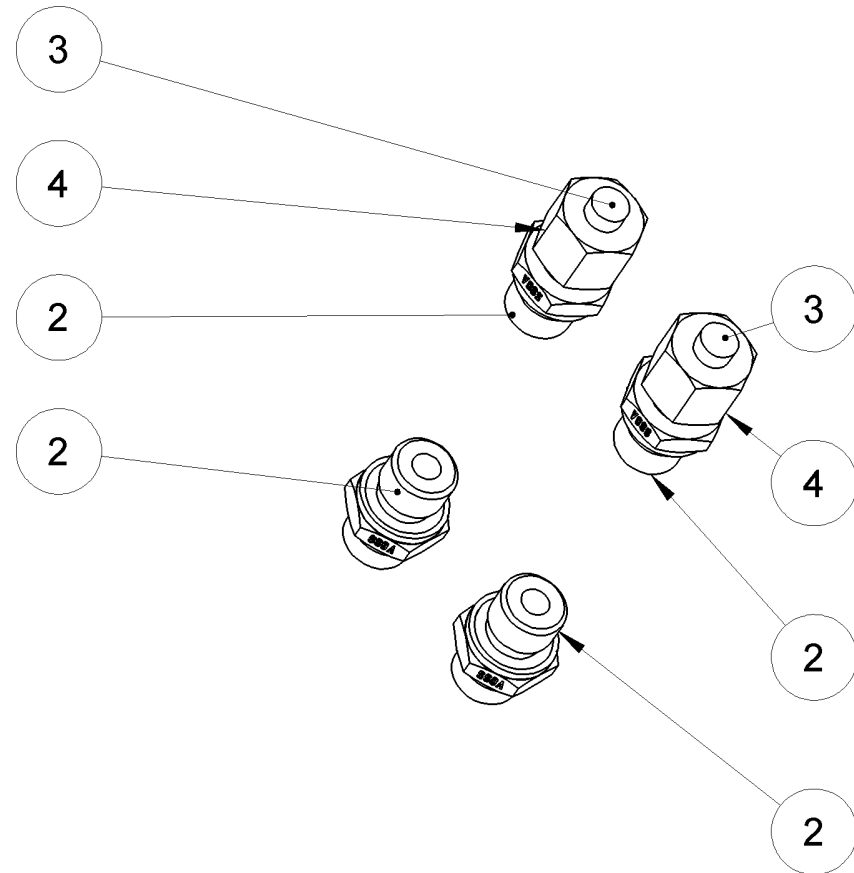
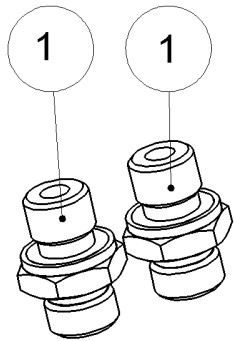

Pos.		Bestell-Nr. Stock Number Numéro de Commande Номер товара	Menge Amount Quantité Количество	Beschreibung	Description	Description	Описание
10		20.04.00030/00	2,000	EINSCHRAUBSTUTZEN JIC37	SCREW-IN FITTING JIC37	SCREW-IN FITTING JIC37	
20		20.04.00014/00	4,000	EINSCHRAUBSTUTZEN JIC37	EINSCHRAUBSTUTZEN JIC37	EINSCHRAUBSTUTZEN JIC37	
30		20.04.00021/00	2,000	VERSCHLUSSSTOPFEN JIC37 8 PN315 SW17	VERSCHLUSSSTOPFEN JIC37 8 PN315 SW17	VERSCHLUSSSTOPFEN JIC37 8 PN315 SW17	



HYDRAULIK FUER Klappe DIN - HYDRAULICS DIN
 HYDRAULICS DIN - 560.15.00.00.00/A

560.15.00.00.00/A
 Stücklistennummer / Piece Number / Liste de Pièces / Номер





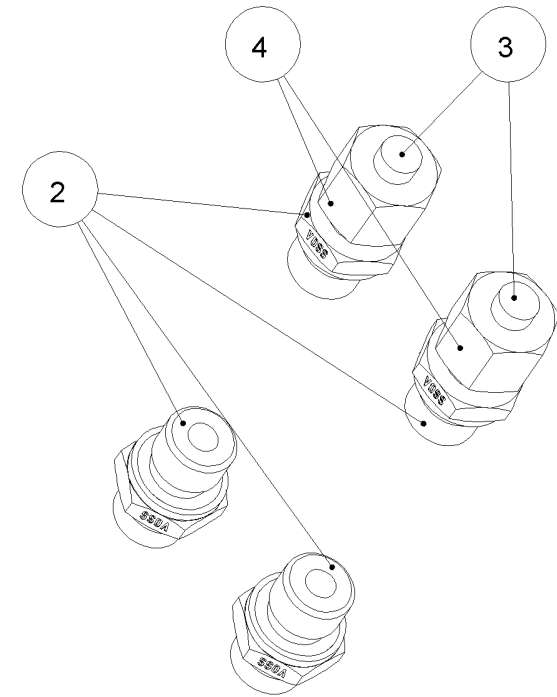
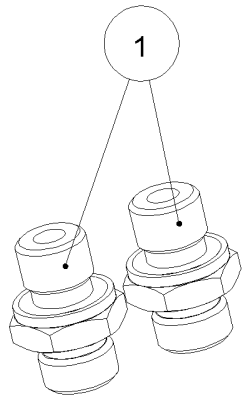

Pos.	Bestell-Nr. Stock Number Numéro de Commande Номер товара	Menge Amount Quantité Количество	Beschreibung	Description	Description	Описание
10	 20.GEV08L1.4/00	2,000	GER-EINSCHR-VERSCHR. 8L G 1/4	MALE STUD COUPLING 08L 1/4"	MALE STUD COUPLING 08L 1/4"	
20	 20.GEV08L.M14-1.5/00	4,000	GER-EINSCHR-VERSCHR. 8L	MALE STUD COUPLING 08L M14-1.5	MALE STUD COUPLING 08L M14-1.5	
30	 20.BUZ08L/00	2,000	VERSCHLUSSSTOPFEN 8L PN500 SW17	FITTING FOR MEASURE 8L C/ NUT	FITTING FOR MEASURE 8L C/ NUT	
40	 20.UEM08L/00	2,000	UEBERWURFMUTTER 8L M14X1,5 PN500, SW17	UNION NUT 8L M14-1.5	UNION NUT 8L M14-1.5	
50	 20.02.14.08.0450.B/00	2,000	HYDRAULIKSCHLAUCH	HYDRAULIC HOSE	BOYAU HYDRAULIQUE	



HYDRAULIK FUER Klappe DIN - HYDRAULICS DIN
 HYDRAULICS DIN - 560.15.00.00.00/A

560.15.00.00.00/A
 Stücklistennummer / Piece Number / Liste de Pièces / Номер



Pos.	Bestell-Nr. Stock Number Numéro de Commande Номер товара	Menge Amount Quantité Количество	Beschreibung	Description	Description	Описание
10	 20.GEV08L1.4/00	2,000	GER-EINSCHR-VERSCHR. 8L G 1/4	MALE STUD COUPLING 08L 1/4"	MALE STUD COUPLING 08L 1/4"	
20	 20.GEV08L.M14-1.5/00	4,000	GER-EINSCHR-VERSCHR. 8L	MALE STUD COUPLING 08L M14-1.5	MALE STUD COUPLING 08L M14-1.5	
30	 20.BUZ08L/00	2,000	VERSCHLUSSSTOPFEN 8L PN500 SW17	FITTING FOR MEASURE 8L C/ NUT	FITTING FOR MEASURE 8L C/ NUT	
40	 20.UEM08L/00	2,000	UEBERWURFMUTTER 8L M14X1,5 PN500, SW17	UNION NUT 8L M14-1.5	UNION NUT 8L M14-1.5	
50	 20.02.14.08.0450.B/00	2,000	HYDRAULIKSCHLAUCH	HYDRAULIC HOSE	BOYAU HYDRAULIQUE	

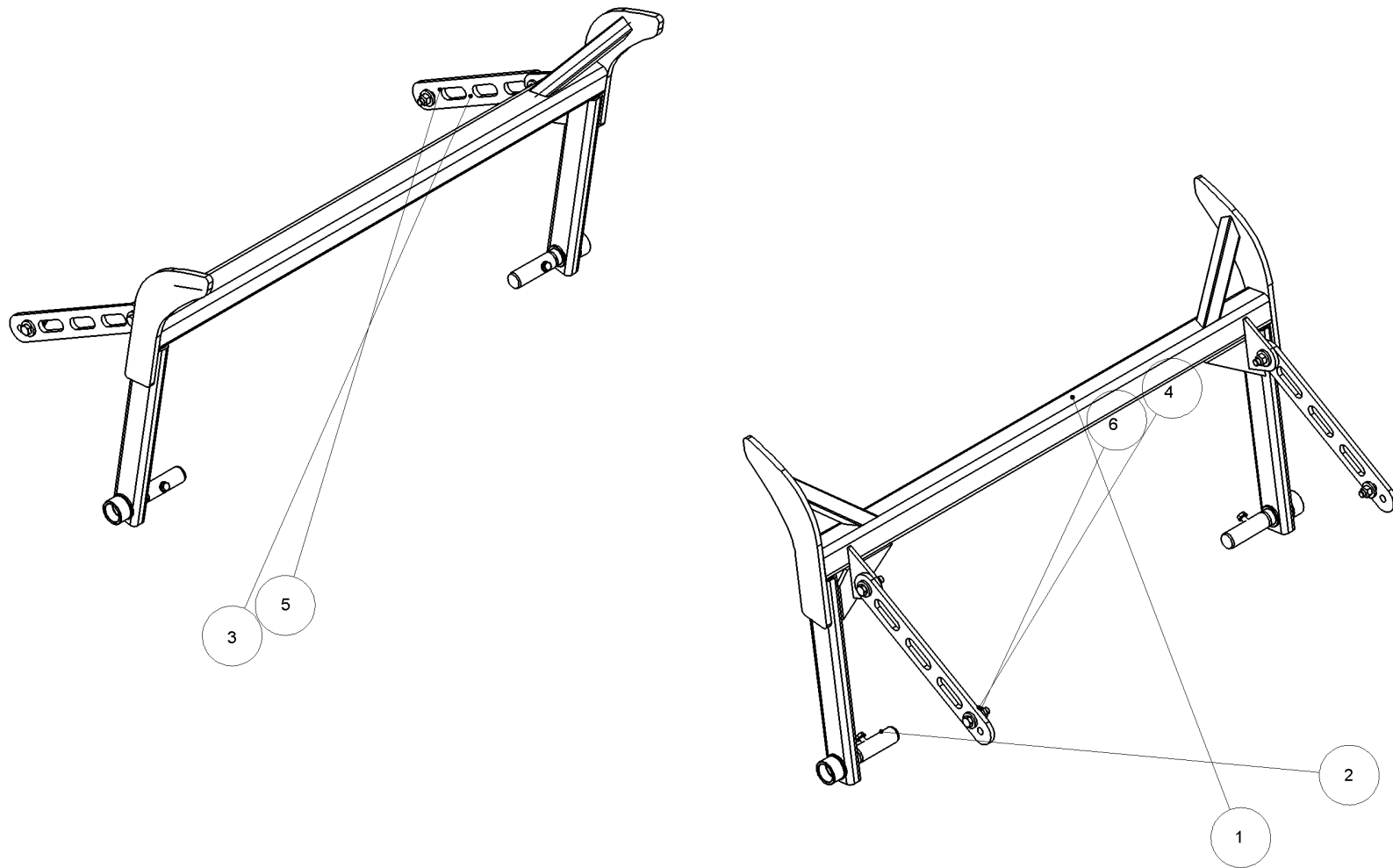

DRUECKEVORRICHTUNG STARR GESCHRAUBT - FIXED PUSH-BAR
 FIXED PUSH-BAR - 560.07.00.01.00/00

560.07.00.01.00/00
 Stücklistennummer / Piece Number / Liste de Pièces / Homep



Pos.		Bestell-Nr. Stock Number Numéro de Commande Номер товара	Menge Amount Quantité Количество	Beschreibung	Description	Description	Описание
10		560.07.00.20.00/00	1,000	DRUECKEVORRICHTUNG GESCHWEISST	DRUECKEVORRICHTUNG GESCHWEISST	DRUECKEVORRICHTUNG GESCHWEISST	
20		551.07.01.01.00/A	2,000	<u>BOLZEN FUER Klappe</u>	BOLZEN FUER Klappe	BOLZEN FUER Klappe	
30		560.07.00.01.01/A	2,000	STREBE	STREBE	STREBE	
40		05.04.17	8,000	SCHEIBE B17	WASHER B17 DIN 7349 GALVANIZED	WASHER B17 DIN 7349 GALVANIZED	
50		01.10.16060	4,000	SKT-SCHRAUBE M16X60 8.8	SCREW M16X60 DIN 933	SCREW M16X60 DIN 933	
60		03.02.16	4,000	SKT-MUTTER M16 8, SELBSTSICH.	NUT M16 DIN980V SELF- LOCKING	NUT M16 DIN980V SELF- LOCKING	

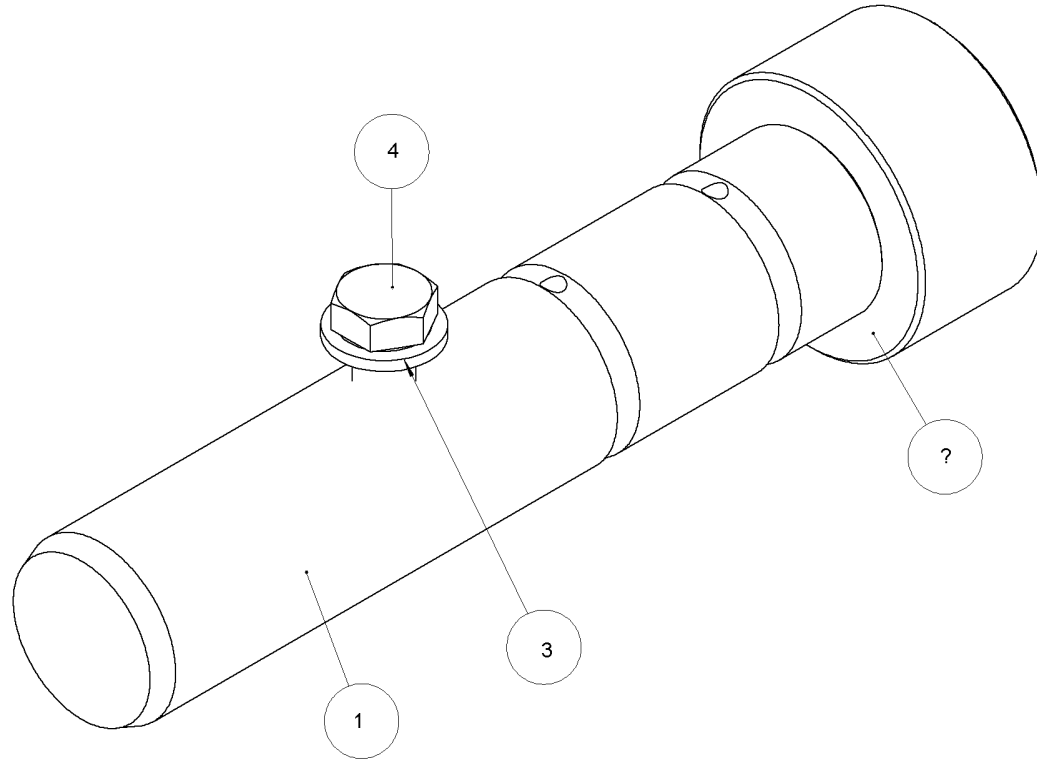



BOM:560.00.00.00.00 MAT: 551.07.01.01.00 DRW/551.07.01.01.00/DE/A I0005427 2020-07-16

BOLZEN FUER Klappe - BOLZEN FUER Klappe
 BOLZEN FUER Klappe - 551.07.01.01.00/A

551.07.01.01.00/A
 Stücklistennummer / Piece Number / Liste de Pièces / Номер



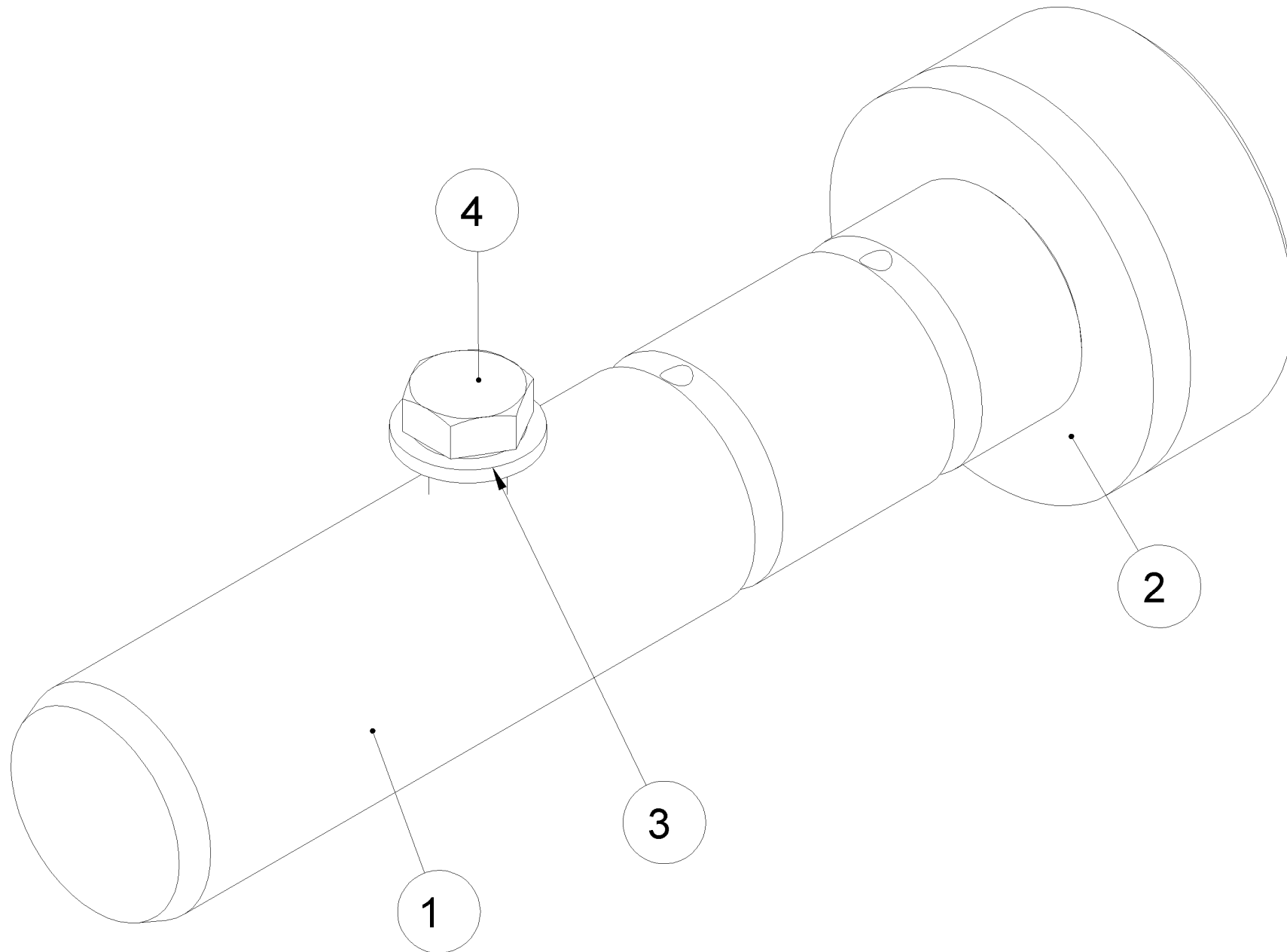

Pos.	Bestell-Nr. Stock Number Numéro de Commande Номер товара	Menge Amount Quantité Количество	Beschreibung	Description	Description	Описание
10	 551.07.01.01.01/00	1,000	BOLZEN MIT BOHRUNG D40	BOLZEN MIT BOHRUNG D40	BOLZEN MIT BOHRUNG D40	
20	 551.07.00.00.02/00	1,000	SCHUTZRING	SCHUTZRING	SCHUTZRING	
30	 05.01.13	1,000	SCHEIBE ISO 7090-13-200HV	WASHER B13 DIN 125 GALVANIZED	WASHER B13 DIN 125 GALVANIZED	
40	01.10.12030	1,000	SKT-SCHRAUBE M12X30 8.8	SCREW M12X30 DIN 933	SCREW M12X30 DIN 933	



BOLZEN FUER Klappe - BOLZEN FUER Klappe
 BOLZEN FUER Klappe - 551.07.01.01.00/A

551.07.01.01.00/A
 Stücklistennummer / Piece Number / Liste de Pièces / Номер



Pos.	Bestell-Nr. Stock Number Numéro de Commande Номер товара	Menge Amount Quantité Количество	Beschreibung	Description	Description	Описание
10	 551.07.01.01.01/00	1,000	BOLZEN MIT BOHRUNG D40	BOLZEN MIT BOHRUNG D40	BOLZEN MIT BOHRUNG D40	
20	 551.07.00.00.02/00	1,000	SCHUTZRING	SCHUTZRING	SCHUTZRING	
30	 05.01.13	1,000	SCHEIBE ISO 7090-13-200HV	WASHER B13 DIN 125 GALVANIZED	WASHER B13 DIN 125 GALVANIZED	
40	01.10.12030	1,000	SKT-SCHRAUBE M12X30 8.8	SCREW M12X30 DIN 933	SCREW M12X30 DIN 933	

DISTANZEN - DISTANCE BUSHINGS
DISTANCE BUSHINGS - 560.07.00.00.00/00

560.07.00.00.00/00
Stücklistennummer / Piece Number / Liste de Pièces / Номер



Pos.	Bestell-Nr. Stock Number Numéro de Commande Номер товара	Menge Amount Quantité Количество	Beschreibung	Description	Description	Описание
------	---	---	--------------	-------------	-------------	----------

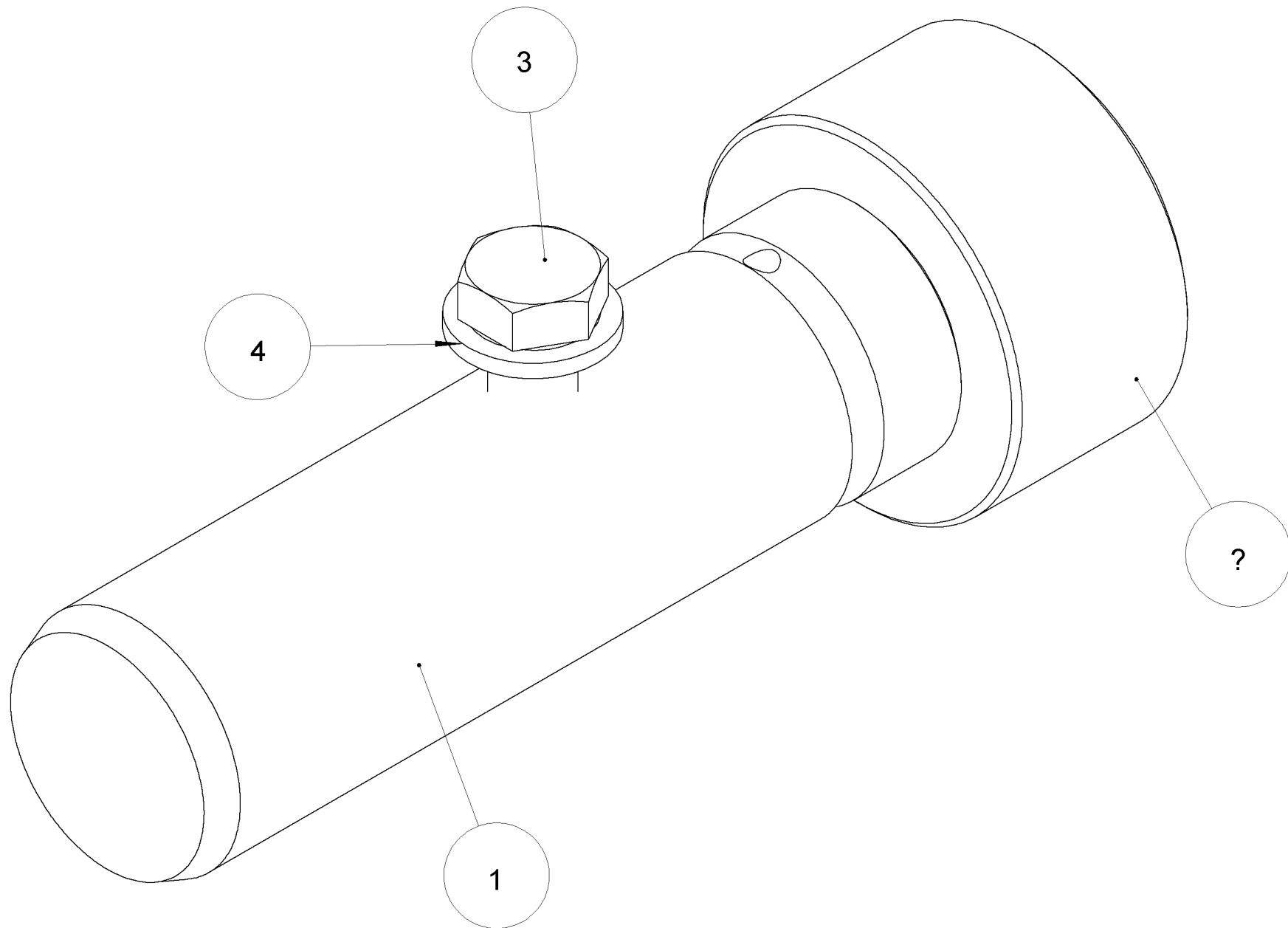

10	 551.07.01.00.00/A	2,000	<u>BOLZEN FUER KLAPPE KLEIN</u>	BOLZEN FUER KLAPPE KLEIN	BOLZEN FUER KLAPPE KLEIN	
----	---	-------	---------------------------------	--------------------------	--------------------------	--



BOLZEN FUER Klappe Klein - BOLZEN FUER Klappe Klein
 BOLZEN FUER Klappe Klein - 551.07.01.00.00/A

551.07.01.00.00/A
 Stücklistennummer / Piece Number / Liste de Pièces / Номер



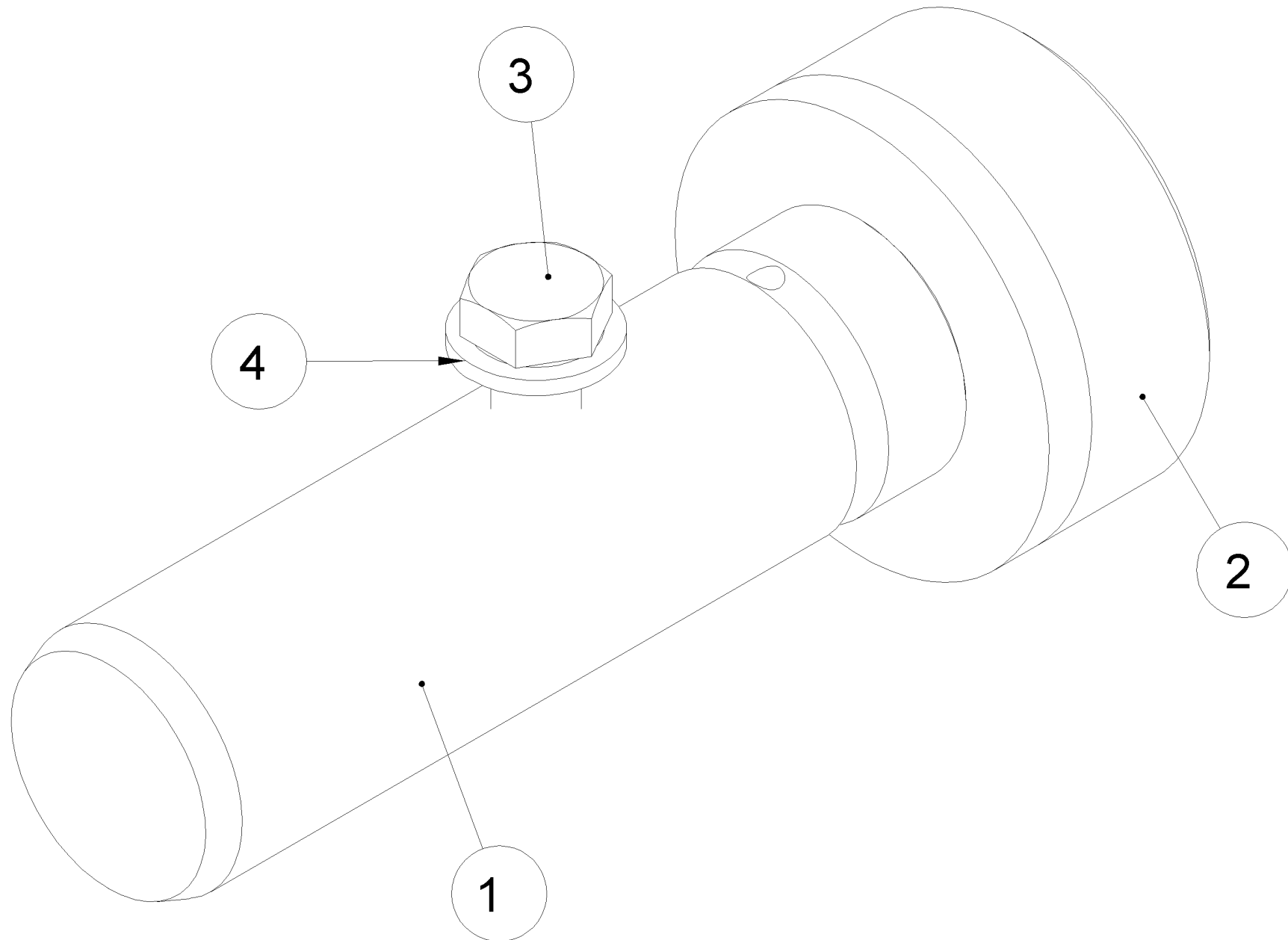

Pos.	Bestell-Nr. Stock Number Numéro de Commande Номер товара	Menge Amount Quantité Количество	Beschreibung	Description	Description	Описание
10	 551.07.00.00.01/00	1,000	BOLZEN MIT BOHRUNG	BOLZEN MIT BOHRUNG	BOLZEN MIT BOHRUNG	
20	 551.07.00.00.02/00	1,000	SCHUTZRING	SCHUTZRING	SCHUTZRING	
30	01.10.12030	1,000	SKT-SCHRAUBE M12X30 8.8	SCREW M12X30 DIN 933	SCREW M12X30 DIN 933	
40	 05.01.13	1,000	SCHEIBE ISO 7090-13-200HV	WASHER B13 DIN 125 GALVANIZED	WASHER B13 DIN 125 GALVANIZED	



BOLZEN FUER Klappe Klein - BOLZEN FUER Klappe Klein
 BOLZEN FUER Klappe Klein - 551.07.01.00.00/A

551.07.01.00.00/A
 Stücklistennummer / Piece Number / Liste de Pièces / Номер



Pos.	Bestell-Nr. Stock Number Numéro de Commande Номер товара	Menge Amount Quantité Количество	Beschreibung	Description	Description	Описание
10	 551.07.00.00.01/00	1,000	BOLZEN MIT BOHRUNG	BOLZEN MIT BOHRUNG	BOLZEN MIT BOHRUNG	
20	 551.07.00.00.02/00	1,000	SCHUTZRING	SCHUTZRING	SCHUTZRING	
30	01.10.12030	1,000	SKT-SCHRAUBE M12X30 8.8	SCREW M12X30 DIN 933	SCREW M12X30 DIN 933	
40	 05.01.13	1,000	SCHEIBE ISO 7090-13-200HV	WASHER B13 DIN 125 GALVANIZED	WASHER B13 DIN 125 GALVANIZED	

ROTOR D550 1300 24XBCS - ROTOR D550 1300 24XBCS
ROTOR D550 1300 24XBCS - 857.03.00.64.00/01

857.03.00.64.00/01

Stücklistennummer / Piece Number / Liste de Pièces / Homep



ROTOR D550 1300 24XBCS - ROTOR D550 1300 24XBCS
 ROTOR D550 1300 24XBCS - 857.03.00.64.00/01

857.03.00.64.00/01
 Stücklistennummer / Piece Number / Liste de Pièces / Номер



Pos.	Bestell-Nr. Stock Number Numéro de Commande Номер товара	Menge Amount Quantité Количество	Beschreibung	Description	Description	Описание
1	 857.03.01.64.00/02	1,000	<u>ROTOR-GESCHWEISST</u>	ROTOR-WELDED	ROTOR-SOUDE	
2	 753.32.1.01/D	1,000	ROTORWELLENSTUMMEL D65	ROTOR SHAFT STUMP	ROTOR SHAFT STUMP	
3	 740.03.00.00.01/01	1,000	<u>ROTORSTUMMEL KURZ</u>	ROTOR SHOFT	ROTOR SHOFT	
4	 46.BCS02/00	24,0-00	WERKZEUG BCS02	TOOL BCS02	OUTIL BCS02	
5	41408356/00	2,000	SEITENRAEUMER BCS-LINKS	SIDE SCRAPER BCS-LEFT	DEFLECTEUR BCS-GAUCHE	
6	41408355/00	2,000	SEITENRAEUMER BCS-RECHTS	SIDE SCRAPER BCS-RIGHT	DEFLECTEUR BCS-DROITE	
7	41368767/01	24,0-00	WERKZEUG BCS03	TOOL BCS03	OUTIL BCS03	
8	 01.20.16040.C	56,0-00	ZYLINDERSCHRAUBE M16X40 10.9 VERGUETET	CYL. HEAD SCREW M16X40 DIN 912	CYL. HEAD SCREW M16X40 DIN 912	
9	 01.21.16050.C	12,0-00	ZYLINDERSCHRAUBE M16X50	SCREW M16X50 DIN6912	SCREW M16X50 DIN6912	

ROTOR-GESCHWEISST - ROTOR-WELDED
ROTOR-SOUDE - 857.03.01.64.00/02



857.03.01.64.00/02
Stücklistennummer / Piece Number / Liste de Pièces / Homep



ROTOR-GESCHWEISST - ROTOR-WELDED
 ROTOR-SOUDE - 857.03.01.64.00/02

857.03.01.64.00/02
 Stücklistennummer / Piece Number / Liste de Pièces / Номер



Pos.	Bestell-Nr. Stock Number Numéro de Commande Номер товара	Menge Amount Quantité Количество	Beschreibung	Description	Description	Описание
5	 857.03.03.28.02/00	4,000	VERSCHLEISSCHUTZ	WEAR PROTECTION	WEAR PROTECTION	
6	 46.BCS01/01	28,0- 00	WERKZEUG-HALTER BCS01	TOOL-SUPPORT BCS01	OUTIL-SUPPORT BCS01	

ROTORSTUMMEL KURZ - ROTOR SHOFT
ROTOR SHOFT - 740.03.00.00.01/01

740.03.00.00.01/01
Stücklistennummer / Piece Number / Liste de Pièces / Homep



ROTORSTUMMEL KURZ - ROTOR SHOFT
ROTOR SHOFT - 740.03.00.00.01/01

740.03.00.00.01/01
Stücklistennummer / Piece Number / Liste de Pièces / Номер



Pos.	Bestell-Nr. Stock Number Numéro de Commande Номер товара	Menge Amount Quantité Количество	Beschreibung	Description	Description	Описание
------	---	---	--------------	-------------	-------------	----------

1	 754.03.00.00.01/1	1,000	ROTORWELLENSTUMMEL D65	ROTOR SHAFT STUB FM500	ROTOR SHAFT STUB FM500	
---	---	-------	------------------------	------------------------	------------------------	--

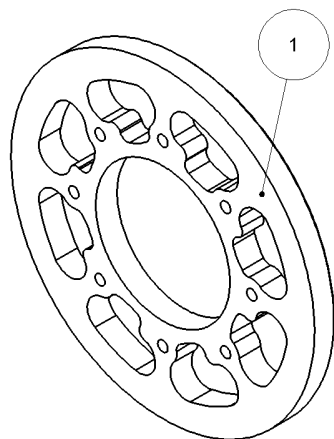
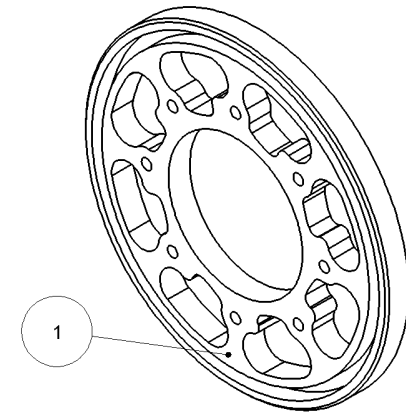

LABYRINTHDICHTUNG M550 - LABYRINTHDICHTUNG M550
 LABYRINTHDICHTUNG M550 - 551.03.00.02.00/00

551.03.00.02.00/00
 Stücklistennummer / Piece Number / Liste de Pièces / Номер



Pos.	Bestell-Nr. Stock Number Numéro de Commande Номер товара	Menge Amount Quantité Количество	Beschreibung	Description	Description	Описание
10	 551.03.00.00.02/00	2,000	LABYRINTHDICHTUNG M550 FUER BCS ROTOR	LABYRINTH SEAL - M550E	LABYRINTH SEAL - M550E	
20	 85.01.133/02	2,000	AUFKLEBER- ANZIEHDREHMOMENT BCS	STICKER-TIGHTENING TORQUE BCS	AUTOCOLLANT-COUPLE DE SERRAGE BCS	

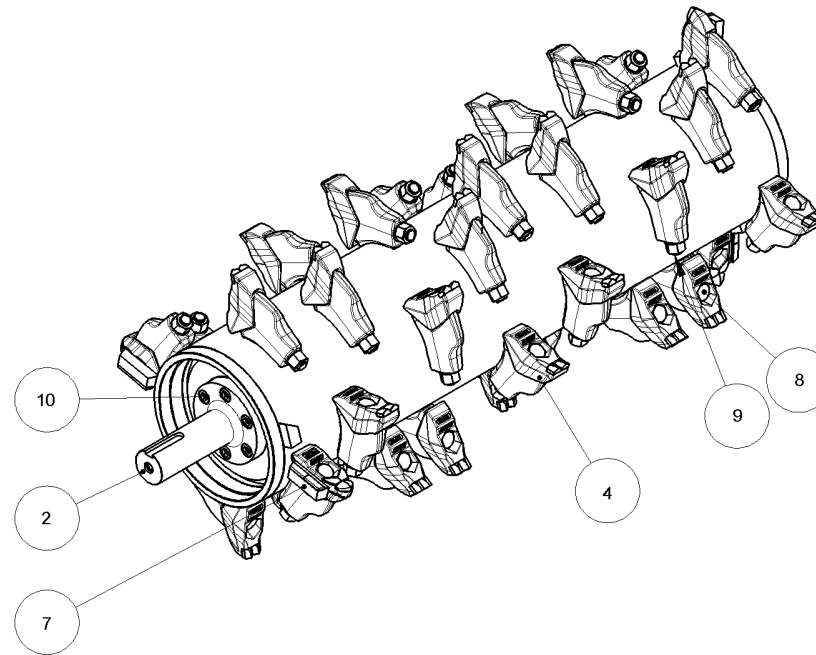
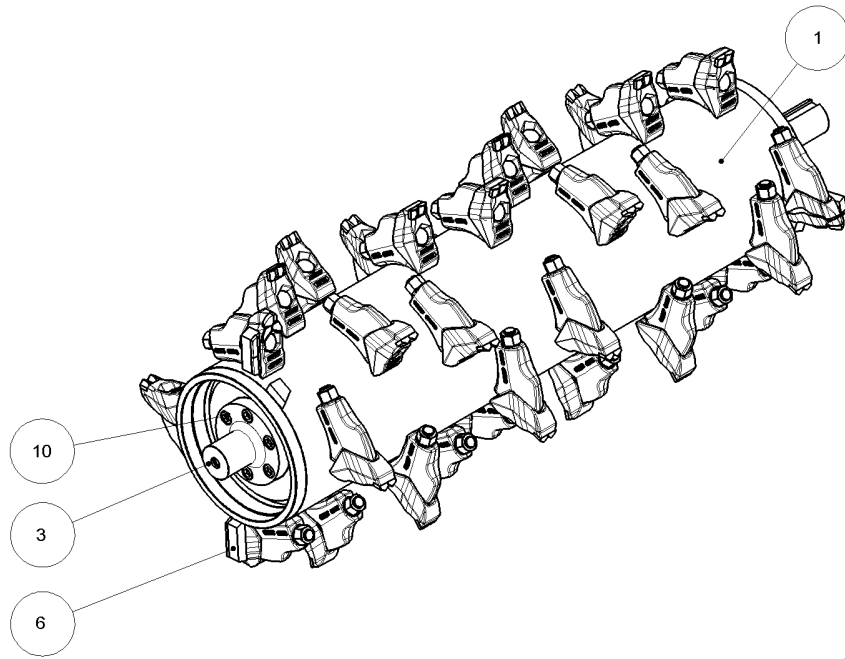

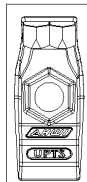
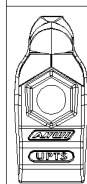









	<p>Pos. 4</p>	<p>Option 46.UPTS02 Option 46.UPTS02 Option 46.UPTS02 Вариант 46.UPTS02</p>
	<p>Pos. 5</p>	<p>Option 46.UPTS04 Option 46.UPTS04 Option 46.UPTS04 Вариант 46.UPTS04</p>

BOM:560.00.00.00 MAT: 857.03.00.63.00 DRW/857.03.00.63.00/DE/100 10005427 2020-07-16

ROTOR D550 1300 32XUPTS - ROTOR D550 1300 32XUPTS
 ROTOR D550 1300 32XUPTS - 857.03.00.63.00/00

857.03.00.63.00/00
 Stücklistennummer / Piece Number / Liste de Pièces / Номер



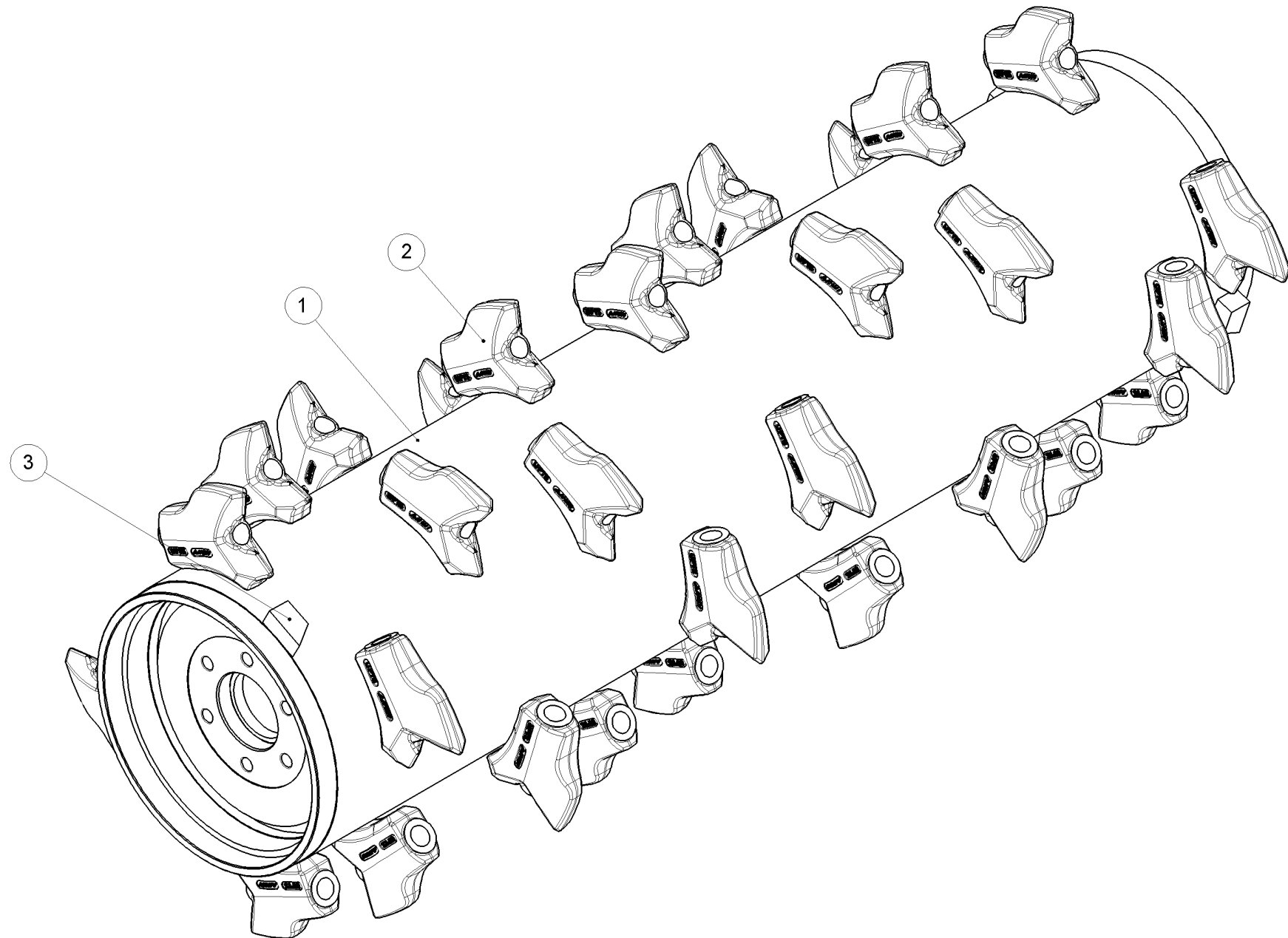

Pos.		Bestell-Nr. Stock Number Numéro de Commande Номер товара	Menge Amount Quantité Количество	Beschreibung	Description	Description	Описание
10		857.03.01.63.00/01	1,000	<u>ROTOR-GESCHWEISST</u>	ROTOR-WELDED	ROTOR-SOUDE	
20		753.32.1.01/D	1,000	ROTORWELLENSTUMMEL D65	ROTOR SHAFT STUMP	ROTOR SHAFT STUMP	
30		740.03.00.00.01/01	1,000	<u>ROTORSTUMMEL KURZ</u>	ROTOR SHOFT	ROTOR SHOFT	
40		46.UPTS02/A	32,0-00	WERKZEUG UPTS02	TOOL UPTS02	OUTIL UPTS02	
50		46.UPTS04/A	32,0-00	WERKZEUG UPTS04	TOOL UPTS04	OUTIL UPTS04	
60		46.UPTS05/B	2,000	<u>WERKZEUG UPTS05</u>	TOOL UPTS05	OUTIL UPTS05	
70		46.UPTS06/B	2,000	<u>WERKZEUG UPTS06</u>	TOOL UPTS06	OUTIL UPTS06	
80		01.80.20.S.155.C	36,0-00	SKT-SCHRAUBE M20X1,5X155	HEX SCREW M20X1,5X155-10.9	HEX SCREW M20X1,5X155-10.9	
90		03.03.20.S.C	36,0-00	SKT-MUTTER M20X1,5 10, SELBSTSICH.	NUT M20X1,5-10 DIN 980 SE- LOCK	NUT M20X1,5-10 DIN 980 SE- LOCK	
100		01.21.16050.C	12,0-00	ZYLINDERSCHRAUBE M16X50	SCREW M16X50 DIN6912	SCREW M16X50 DIN6912	



ROTOR-GESCHWEISST - ROTOR-WELDED
 ROTOR-SOUDE - 857.03.01.63.00/01

857.03.01.63.00/01
 Stücklistennummer / Piece Number / Liste de Pièces / Номер



Pos.		Bestell-Nr. Stock Number Numéro de Commande Номер товара	Menge Amount Quantité Количество	Beschreibung	Description	Description	Описание
20		46.UPTS01/03	36,0-00	WERKZEUG-HALTER UPTS01	TOOL-SUPPORT UPTS01	OUTIL-SUPPORT UPTS01	
30		857.03.03.28.01/00	4,000	VERSCHLEISSSCHUTZ FUER SCHWEISSNAHT	WEAR PROTECTION	WEAR PROTECTION	

ROTORSTUMMEL KURZ - ROTOR SHOFT
ROTOR SHOFT - 740.03.00.00.01/01

740.03.00.00.01/01
Stücklistennummer / Piece Number / Liste de Pièces / Homep



ROTORSTUMMEL KURZ - ROTOR SHOFT
ROTOR SHOFT - 740.03.00.00.01/01

740.03.00.00.01/01
Stücklistennummer / Piece Number / Liste de Pièces / Номер



Pos.	Bestell-Nr. Stock Number Numéro de Commande Номер товара	Menge Amount Quantité Количество	Beschreibung	Description	Description	Описание
------	---	---	--------------	-------------	-------------	----------

1	 740.03.00.00.01/01	1,000	ROTORWELLENSTUMMEL D65	ROTOR SHAFT STUB FM500	ROTOR SHAFT STUB FM500	
---	--	-------	------------------------	------------------------	------------------------	--



WERKZEUG UPTS05 - TOOL UPTS05
OUTIL UPTS05 - 46.UPTS05/B

46.UPTS05/B
Stücklistennummer / Piece Number / Liste de Pièces / Номер



Pos.	Bestell-Nr. Stock Number Numéro de Commande Номер товара	Menge Amount Quantité Количество	Beschreibung	Description	Description	Описание
------	---	---	--------------	-------------	-------------	----------

10	 46.UPTS04/A	1,000	WERKZEUG UPTS04	TOOL UPTS04	OUTIL UPTS04	
----	---	-------	-----------------	-------------	--------------	--

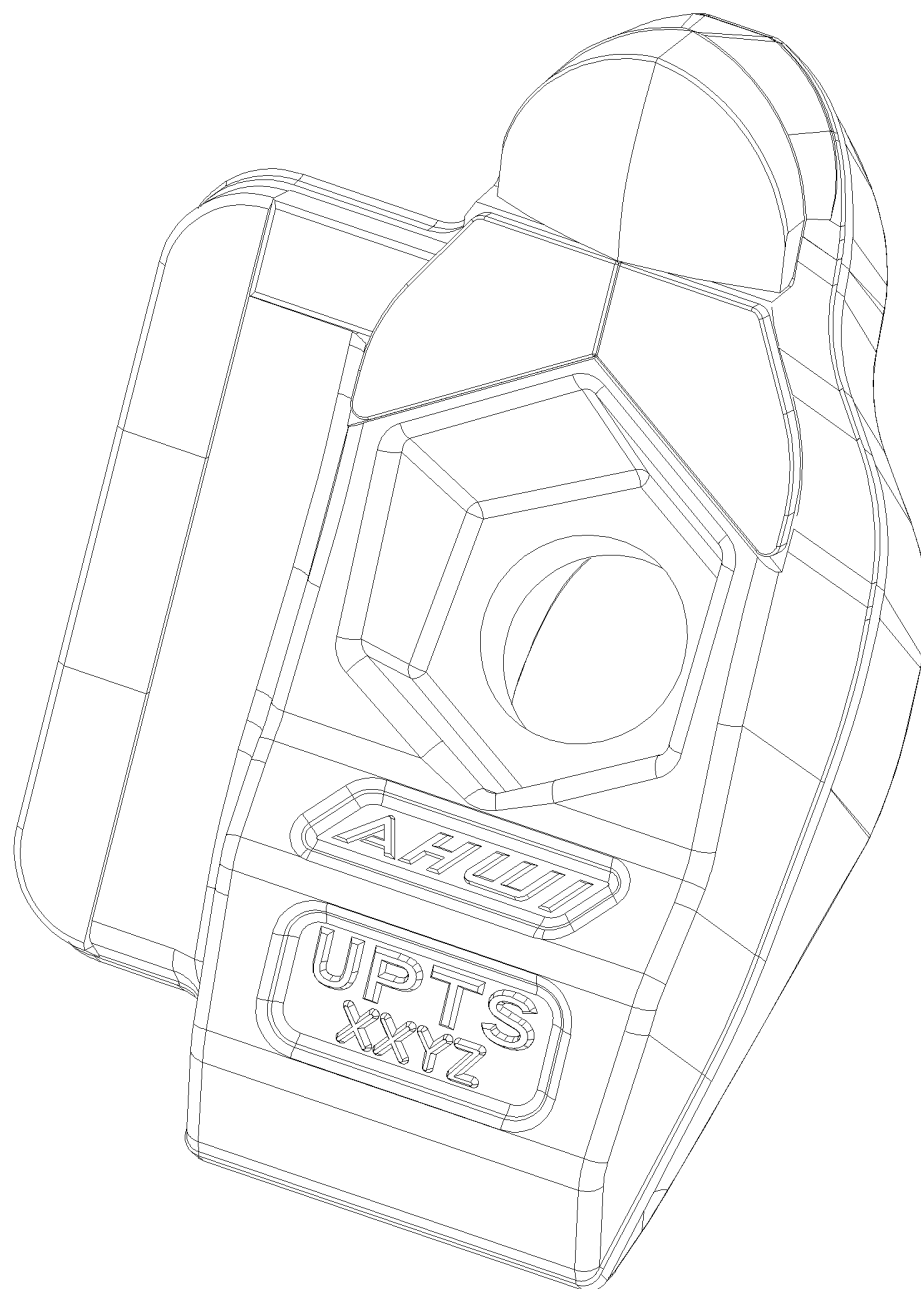

WERKZEUG UPTS05 - TOOL UPTS05
OUTIL UPTS05 - 46.UPTS05/B

46.UPTS05/B
Stücklistennummer / Piece Number / Liste de Pièces / Номер



Pos.	Bestell-Nr. Stock Number Numéro de Commande Номер товара	Menge Amount Quantité Количество	Beschreibung	Description	Description	Описание
------	---	---	--------------	-------------	-------------	----------

10	 46.UPTS04/A	1,000	WERKZEUG UPTS04	TOOL UPTS04	OUTIL UPTS04	
----	---	-------	-----------------	-------------	--------------	--

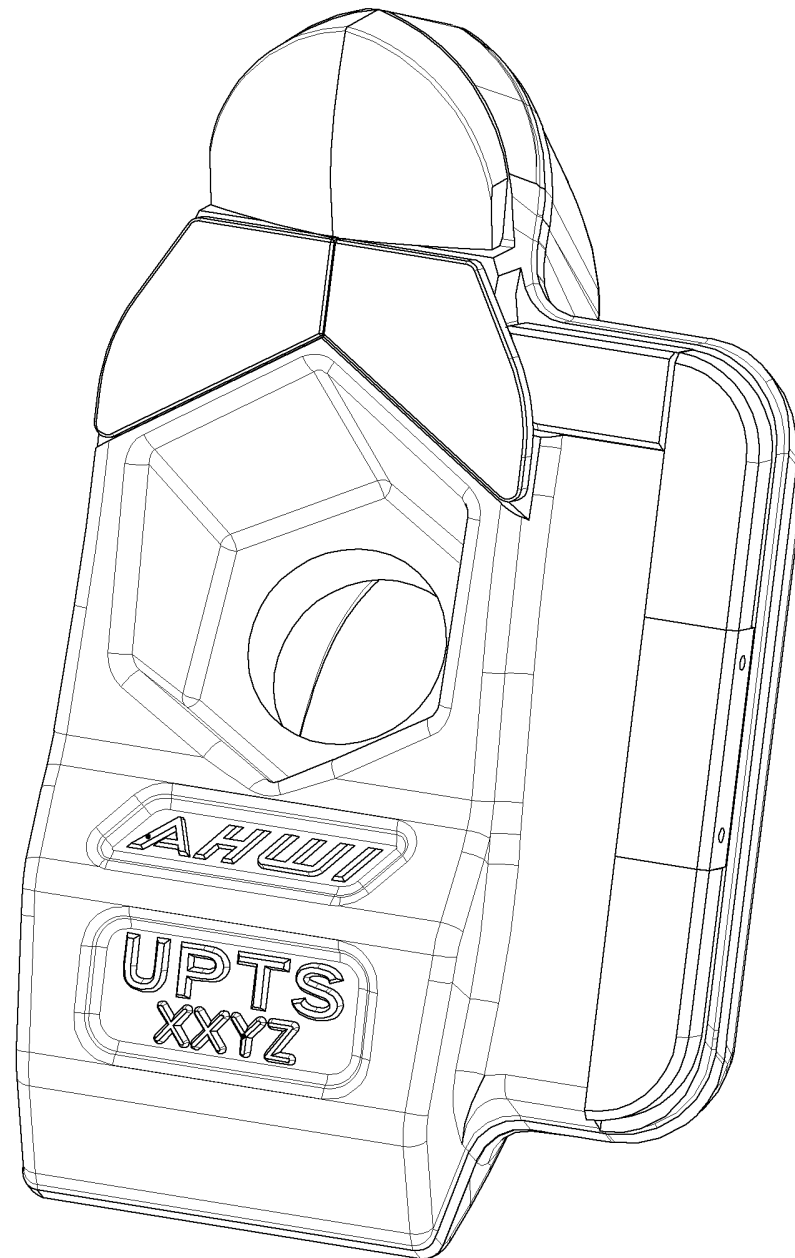

WERKZEUG UPTS06 - TOOL UPTS06
OUTIL UPTS06 - 46.UPTS06/B

46.UPTS06/B
Stücklistennummer / Piece Number / Liste de Pièces / Номер



Pos.	Bestell-Nr. Stock Number Numéro de Commande Номер товара	Menge Amount Quantité Количество	Beschreibung	Description	Description	Описание
------	---	---	--------------	-------------	-------------	----------

10	 46.UPTS04/A	1,000	WERKZEUG UPTS04	TOOL UPTS04	OUTIL UPTS04	
----	---	-------	-----------------	-------------	--------------	--

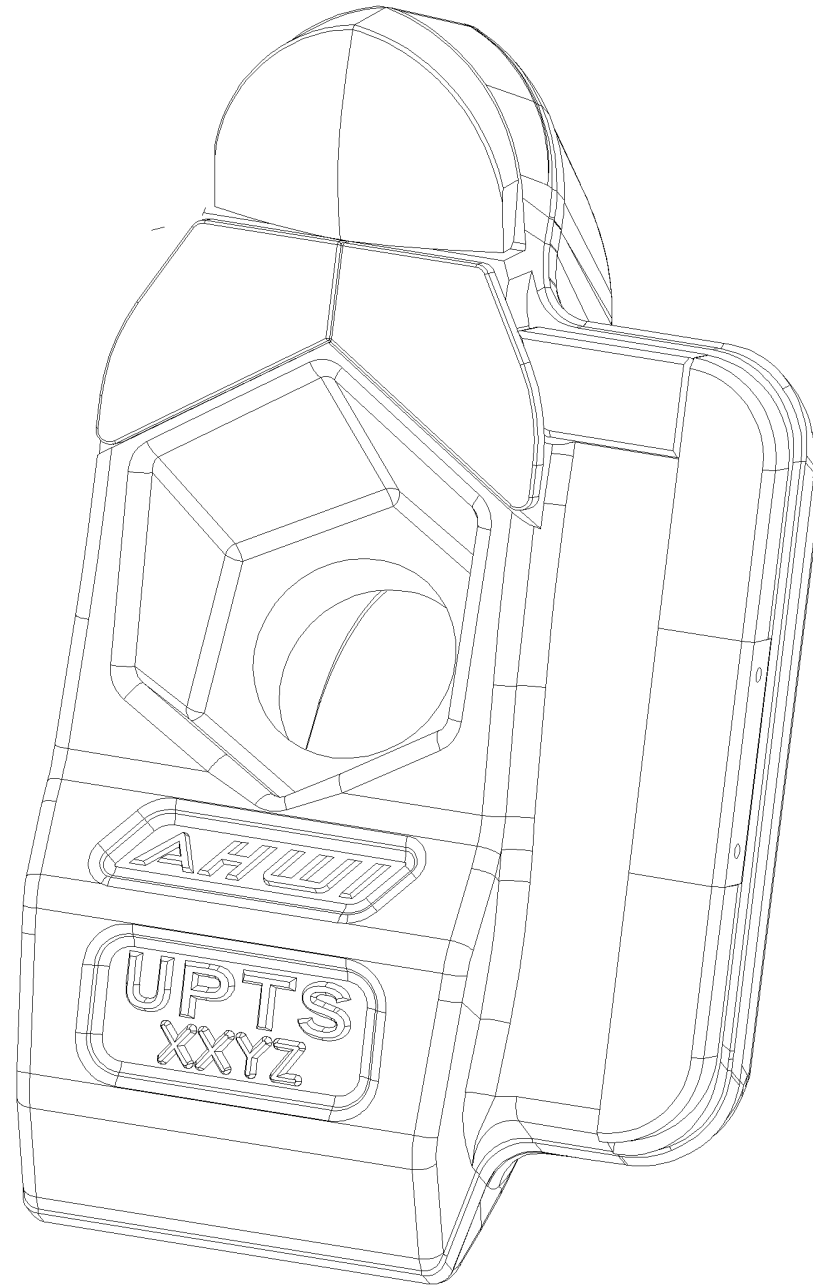

WERKZEUG UPTS06 - TOOL UPTS06
OUTIL UPTS06 - 46.UPTS06/B

46.UPTS06/B
Stücklistennummer / Piece Number / Liste de Pièces / Номер



Pos.	Bestell-Nr. Stock Number Numéro de Commande Номер товара	Menge Amount Quantité Количество	Beschreibung	Description	Description	Описание
------	---	---	--------------	-------------	-------------	----------

10	 46.UPTS04/A	1,000	WERKZEUG UPTS04	TOOL UPTS04	OUTIL UPTS04	
----	---	-------	-----------------	-------------	--------------	--

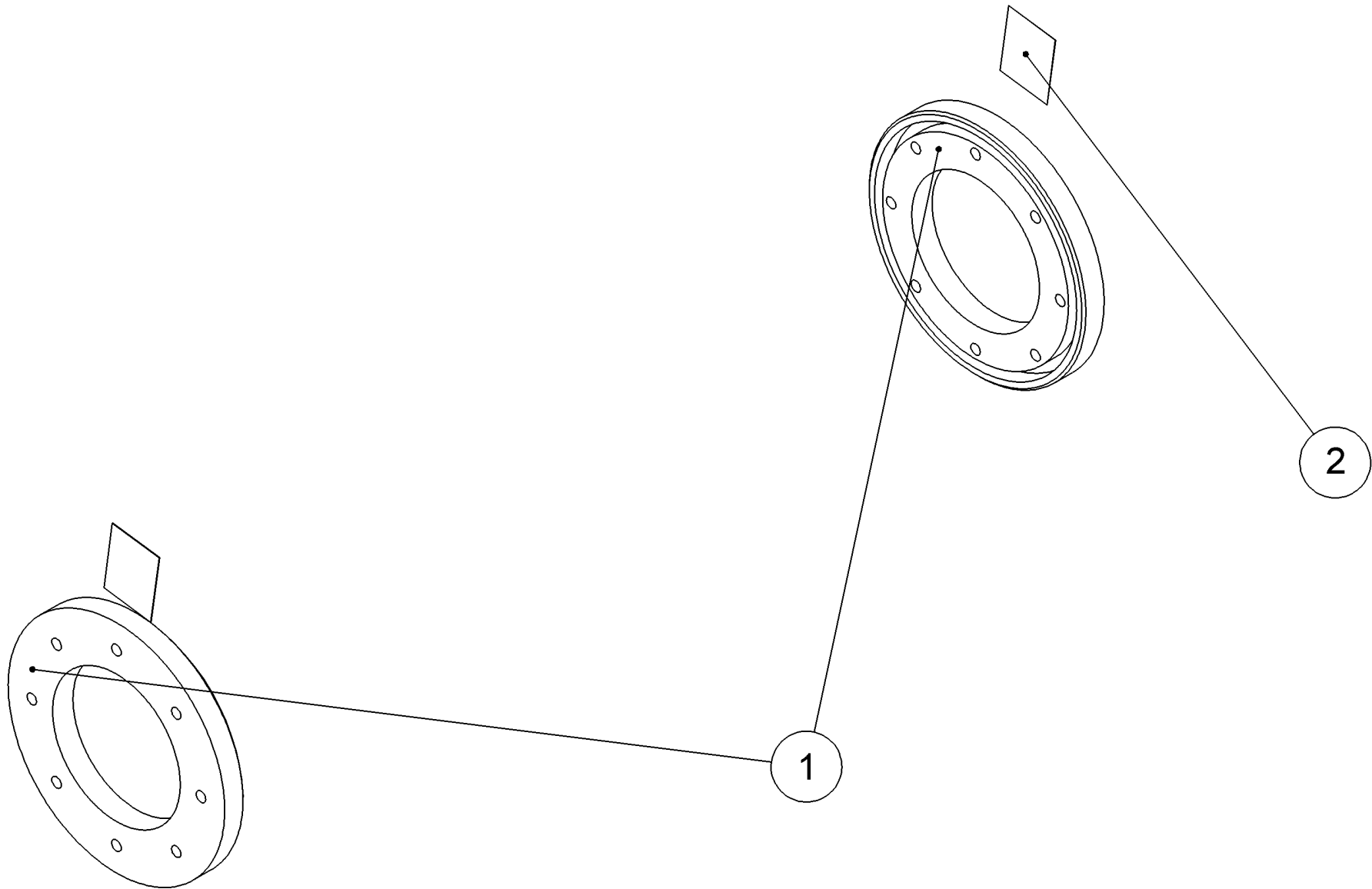

LABYRINTHDICHTUNG-UPTS - LABYRINTH SEALING-UPTS
 LABYRINTH SEALING-UPTS - 41248141/00

41248141/00
 Stücklistennummer / Piece Number / Liste de Pièces / Номер



Pos.	Bestell-Nr. Stock Number Numéro de Commande Номер товара	Menge Amount Quantité Количество	Beschreibung	Description	Description	Описание
10	41248138/00	2,000	LABYRINTHDICHTUNG M550	LABYRINTH SEALING	LABYRINTH SEALING	
20	 85.01.132/02	2,000	AUFKLEBER- ANZIEHDREHMOMENT UPTS	STICKER-TIGHTENING TORQUE UPTS	AUTOCOLLANT-COUPLE DE SERRAGE UPTS	

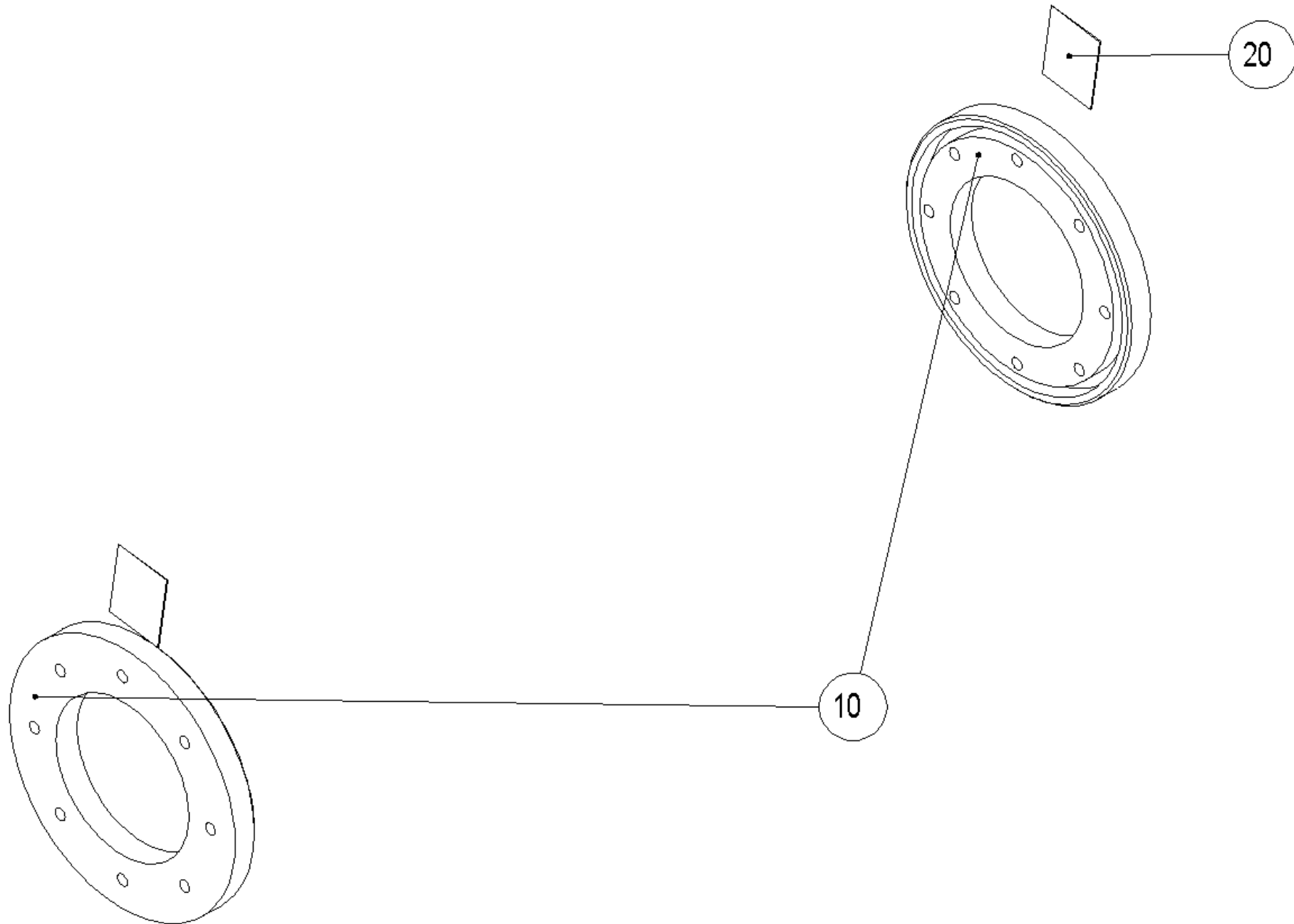

LABYRINTHDICHTUNG-UPTS - LABYRINTH SEALING-UPTS
 LABYRINTH SEALING-UPTS - 41248141/00

41248141/00
 Stücklistennummer / Piece Number / Liste de Pièces / Номер





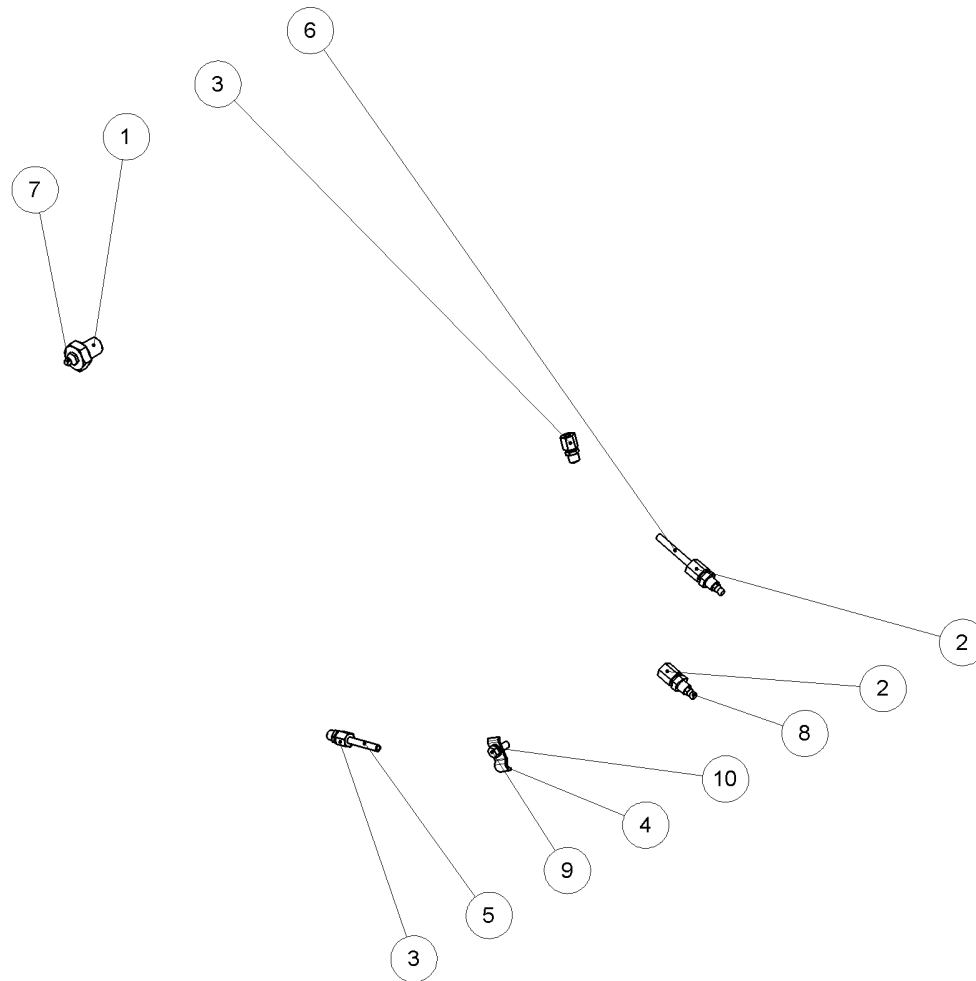



Pos.	Bestell-Nr. Stock Number Numéro de Commande Номер товара	Menge Amount Quantité Количество	Beschreibung	Description	Description	Описание
10	41248138/00	2,000	LABYRINTHDICHTUNG M550	LABYRINTH SEALING	LABYRINTH SEALING	
20	 85.01.132/02	2,000	AUFKLEBER- ANZIEHDREHMOMENT UPTS	STICKER-TIGHTENING TORQUE UPTS	AUTOCOLLANT-COUPLE DE SERRAGE UPTS	



SCHMIERUNG MANUELL - LUBRICATION
LUBRICATION - 560.20.00.00.00/A

560.20.00.00.00/A
Stücklistennummer / Piece Number / Liste de Pièces / Номер





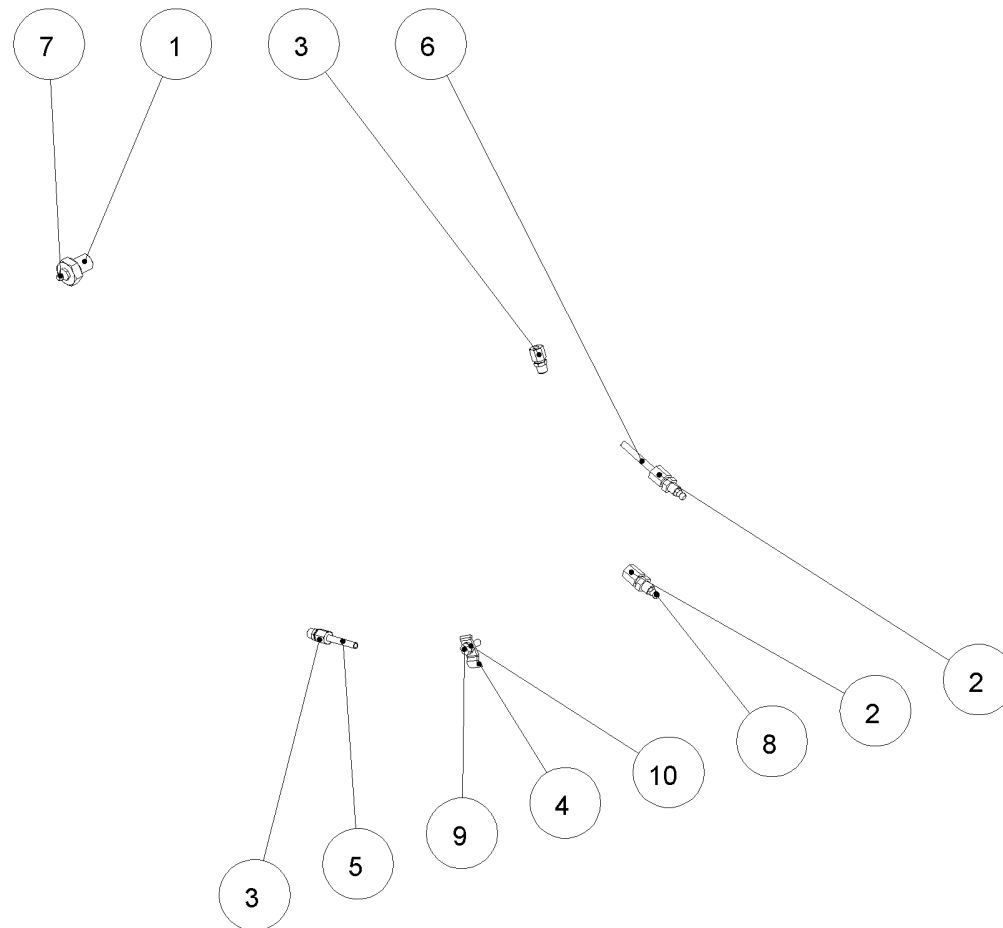





Pos.		Bestell-Nr. Stock Number Numéro de Commande Номер товара	Menge Amount Quantité Количество	Beschreibung	Description	Description	Описание
10		729.10.00.00.03/A	2,000	SCHMIERSCHRAUBE M16X20 INNENGEW. M10X1	GREASE SCREW M16X20	GREASE SCREW M16X20	
20		100302	2,000	GER-EINSCHR-VERSCHR. 6L M10X1	STRAIGHT SCREW FITTING 6L M10	STRAIGHT SCREW FITTING 6L M10	
30		20.GEV06LL.M10-1/00	2,000	GER-EINSCHR-VERSCHR. 6LL M10X1	STRAIGHT SCREW FITTING 6LL M10	STRAIGHT SCREW FITTING 6LL M10	
40		06.04.007.16/00	1,000	BEFESTIGUNGSSCHELLE D7	CLAMP D 7 MM	CLAMP D 7 MM	
50		62.0.010.01.0600/00	1,000	SANCO-KUPFERROHR 6X1 L600, WEICH	SANCO-KUPFERROHR 6X1 L600, WEICH	SANCO-KUPFERROHR 6X1 L600, WEICH	
60		ohne Zeichnung 62.0.010.01.0250/00	1,000	SANCO-KUPFERROHR 6X1 L250, WEICH	SACO-COPPER PIPE 6X1 DIN1786	SACO-COPPER PIPE 6X1 DIN1786	
70		24.A.10.100	2,000	SCHMIERNIPPEL M10X1 GERADE, STAHL	LUBRICATING NIPPLE M10X1	LUBRICATING NIPPLE M10X1	
80		24.A.06.100	2,000	SCHMIERNIPPEL M6X1 GERADE, STAHL	GREASE NIPPLE M6X1	GREASE NIPPLE M6X1	
90		01.10.06016	1,000	SKT-SCHRAUBE M6X16 8.8	SCREW M6X16 DIN 933	SCREW M6X16 DIN 933	
100		05.01.06	1,000	SCHEIBE ISO 7090-6-200HV	WASHER B6,4 DIN 125 GALVANIZED	WASHER B6,4 DIN 125 GALVANIZED	



SCHMIERUNG MANUELL - LUBRICATION
LUBRICATION - 560.20.00.00.00/A

560.20.00.00.00/A
Stücklistennummer / Piece Number / Liste de Pièces / Homep



Pos.	Bestell-Nr. Stock Number Numéro de Commande Номер товара	Menge Amount Quantité Количество	Beschreibung	Description	Description	Описание
10	 729.10.00.00.03/A	2,000	SCHMIERSCHRAUBE M16X20 INNENGEW. M10X1	GREASE SCREW M16X20	GREASE SCREW M16X20	
20	 100302	2,000	GER-EINSCHR-VERSCHR. 6L M10X1	STRAIGHT SCREW FITTING 6L M10	STRAIGHT SCREW FITTING 6L M10	
30	 20.GEV06LL.M10-1/00	2,000	GER-EINSCHR-VERSCHR. 6LL M10X1	STRAIGHT SCREW FITTING 6LL M10	STRAIGHT SCREW FITTING 6LL M10	
40	 06.04.007.16/00	1,000	BEFESTIGUNGSSCHELLE D7	CLAMP D 7 MM	CLAMP D 7 MM	
50	 62.0.010.01.0600/00	1,000	SANCO-KUPFERROHR 6X1 L600, WEICH	SANCO-KUPFERROHR 6X1 L600, WEICH	SANCO-KUPFERROHR 6X1 L600, WEICH	
60	 ohne Zeichnung 62.0.010.01.0250/00	1,000	SANCO-KUPFERROHR 6X1 L250, WEICH	SACO-COPPER PIPE 6X1 DIN1786	SACO-COPPER PIPE 6X1 DIN1786	
70	 24.A.10.100	2,000	SCHMIERNIPPEL M10X1 GERADE, STAHL	LUBRICATING NIPPLE M10X1	LUBRICATING NIPPLE M10X1	
80	 24.A.06.100	2,000	SCHMIERNIPPEL M6X1 GERADE, STAHL	GREASE NIPPLE M6X1	GREASE NIPPLE M6X1	
90	 01.10.06016	1,000	SKT-SCHRAUBE M6X16 8.8	SCREW M6X16 DIN 933	SCREW M6X16 DIN 933	
100	 05.01.06	1,000	SCHEIBE ISO 7090-6-200HV	WASHER B6,4 DIN 125 GALVANIZED	WASHER B6,4 DIN 125 GALVANIZED	



GER-EINSCHR-VERSCHR. 6L M10X1 - STRAIGHT SCREW FITTING 6L M10
 STRAIGHT SCREW FITTING 6L M10 - 100302

100302

Stücklistennummer / Piece Number / Liste de Pièces / Номер





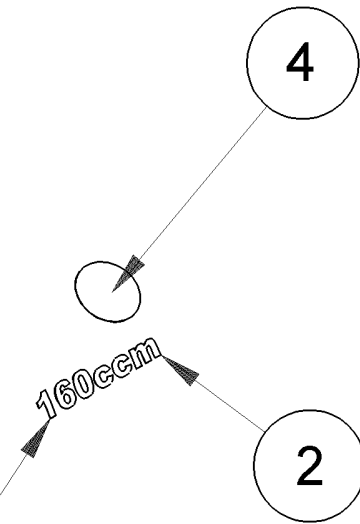



Pos.	Bestell-Nr. Stock Number Numéro de Commande Номер товара	Menge Amount Quantité Количество	Beschreibung	Description	Description	Описание
10	 20.GEV06L.M10-1/00	1,000	GER-EINSCHR-VERSCHR. 6L M10X1	STRAIGHT SCREW FIT. 6L M10X1,0	STRAIGHT SCREW FIT. 6L M10X1,0	



AUFKLEBER ENTSPRECHEND
HY-MOTOR GROESSE VERBAUEN

STICKER SAME AS HYDRAULIC
MOTOR SIZE

Pos.	Bestell-Nr. Stock Number Numéro de Commande Номер товара	Menge Amount Quantité Количество	Beschreibung	Description	Description	Описание
1	41233326/03	1,000	PRODUKTGRAFIK- MULCHGERAET	PRODUCT GRAPHICS-MULCHER	GRAPHIQUE DU PRODUIT- BROYEUR	
2	41375566/00	1,000	AUFKLEBER SET- HYDRAULIKMOTOR	STICKER KIT-HYDRAULIC MOTOR	AUTOCOLLANT KIT-MOTEUR HYDRAULIQUE	
3	 85.01.111/00	1,000	AUFKLEBER M550	AUFKLEBER M550	AUFKLEBER M550	
4	 85.01.33/A	1,000	AUFKLEBER D50 PRUEFPLAKETTE GRUEN	LABEL	LABEL	
5	 85.01.23/00	3,000	AUFKLEBER D30 SCHMIERNIPPEL GELB	STICKER D30	STICKER D30	

Pos.	Bestell-Nr. Stock Number Numéro de Commande Номер товара	Menge Amount Quantité Количество	Beschreibung	Description	Description	Описание
1	 85.01.138/01	1,000	AUFKLEBER- VERDREHSICHERUNG	STICKER-ANTI ROTATION PROTECTION	AUTOCOLLANT-PROTECTION ANTIROTATION	
2	 85.01.148/01	1,000	AUFKLEBER- VERDREHSICHERUNG	STICKER-ANTI ROTATION PROTECTION	AUTOCOLLANT-PROTECTION ANTIROTATION	
3	 85.01.21/00	1,000	GEFAHRENAUFKLEBER 1000 U/ MIN	DANGER STICKER 1000 U/MIN	DANGER STICKER 1000 U/MIN	
4	 85.01.13/00	1,000	GEFAHRENAUFKLEBER ROTIERENDES WERKZEUG	DANGER STICKER ROTATING TOOLS	DANGER STICKER ROTATING TOOLS	
5	 85.01.28/00	1,000	GEFAHRENAUFKLEBER SCHLUESSEL	DANGER STICKER KEY	DANGER STICKER KEY	
6	 85.01.17/00	2,000	GEFAHRENAUFKLEBER STEINFLUG	DANGER STICKER FLYING STONES	DANGER STICKER FLYING STONES	
7	 85.01.22/00	1,000	GEFAHRENAUFKLEBER BETRIEBSANLEITUNG	DANGER STICKER OPERATING INSTR	DANGER STICKER OPERATING INSTR	
8	 85.01.27/00	1,000	GEFAHRENAUFKLEBER MASCHINE AUS	DANGER STICKER MACHINE OFF	DANGER STICKER MACHINE OFF	
9	85.01.20/00	1,000	GEFAHRENAUFKLEBER 1300 U/ MIN	DANGER LABEL	DANGER LABEL	

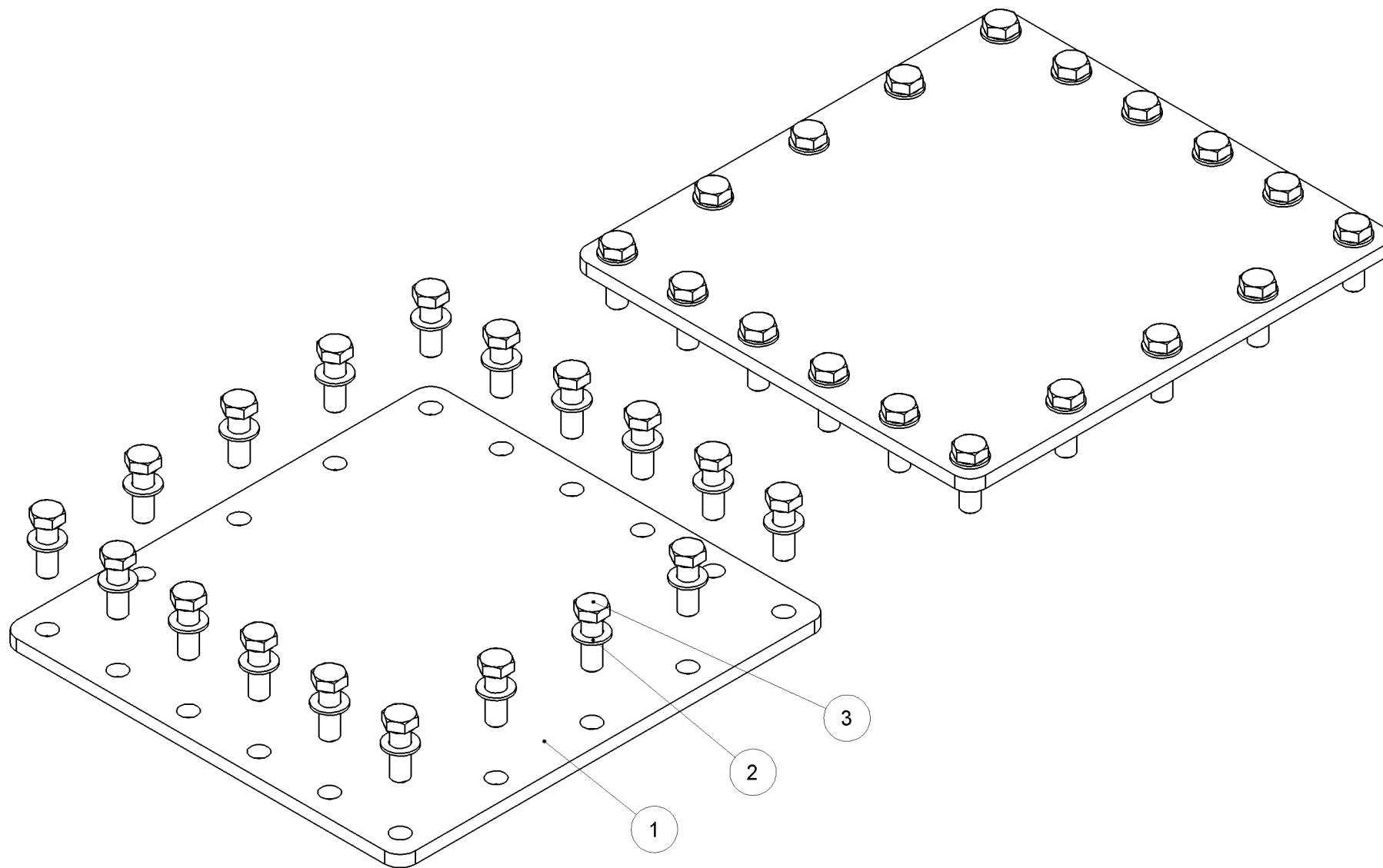

ANBAUPLATTE UNIVERSAL GESCHRAUBT - UNIVERSAL INTERFACE
 UNIVERSAL INTERFACE - 560.32.00.00.00/A

560.32.00.00.00/A
 Stücklistennummer / Piece Number / Liste de Pièces / Номер



Pos.	Bestell-Nr. Stock Number Numéro de Commande Номер товара	Menge Amount Quantité Количество	Beschreibung	Description	Description	Описание
10	 560.32.00.00.01/00	1,000	ANBAUPLATTE UNIVERSAL	ANBAUPLATTE UNIVERSAL	ANBAUPLATTE UNIVERSAL	
20	 05.01.21	18,0-00	SCHEIBE ISO 7090-21-200HV	WASHER B21 DIN 125 GALVANIZED	WASHER B21 DIN 125 GALVANIZED	
30	 01.10.20060.C.V	18,0-00	SKT-SCHRAUBE M20X60 10.9	SCREW M20X60 DIN 933	SCREW M20X60 DIN 933	

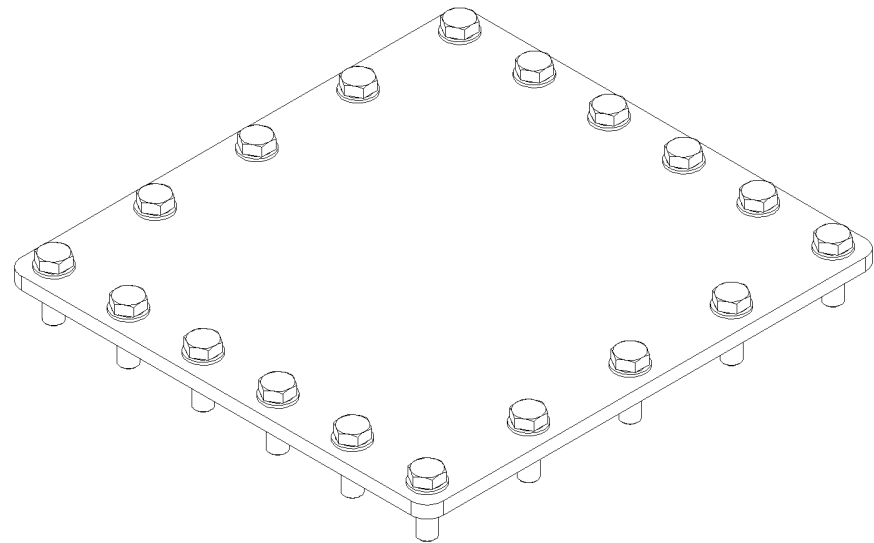
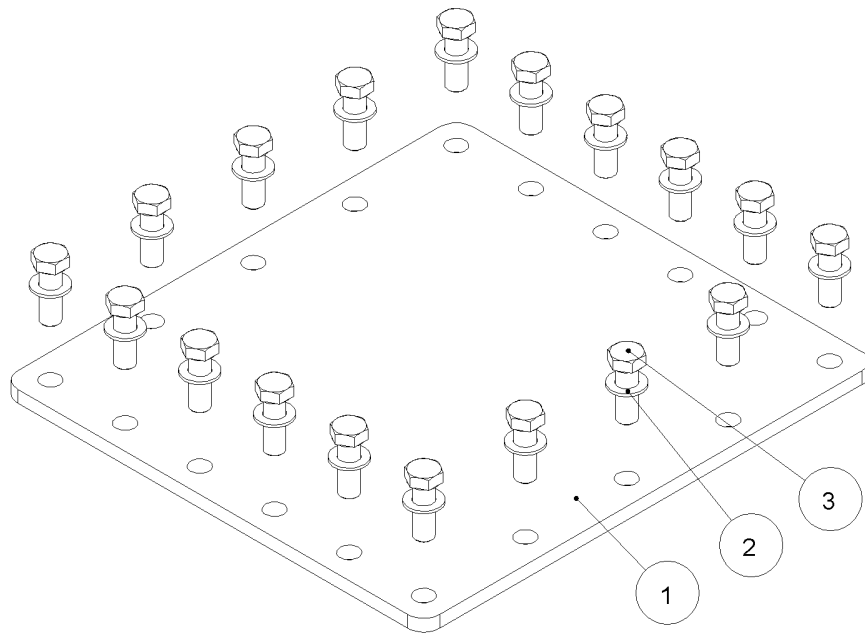

ANBAUPLATTE UNIVERSAL GESCHRAUBT - UNIVERSAL INTERFACE
 UNIVERSAL INTERFACE - 560.32.00.00.00/A

560.32.00.00.00/A
 Stücklistennummer / Piece Number / Liste de Pièces / Номер



Pos.	Bestell-Nr. Stock Number Numéro de Commande Номер товара	Menge Amount Quantité Количество	Beschreibung	Description	Description	Описание
10	 560.32.00.00.01/00	1,000	ANBAUPLATTE UNIVERSAL	ANBAUPLATTE UNIVERSAL	ANBAUPLATTE UNIVERSAL	
20	 05.01.21	18,0-00	SCHEIBE ISO 7090-21-200HV	WASHER B21 DIN 125 GALVANIZED	WASHER B21 DIN 125 GALVANIZED	
30	 01.10.20060.C.V	18,0-00	SKT-SCHRAUBE M20X60 10.9	SCREW M20X60 DIN 933	SCREW M20X60 DIN 933	

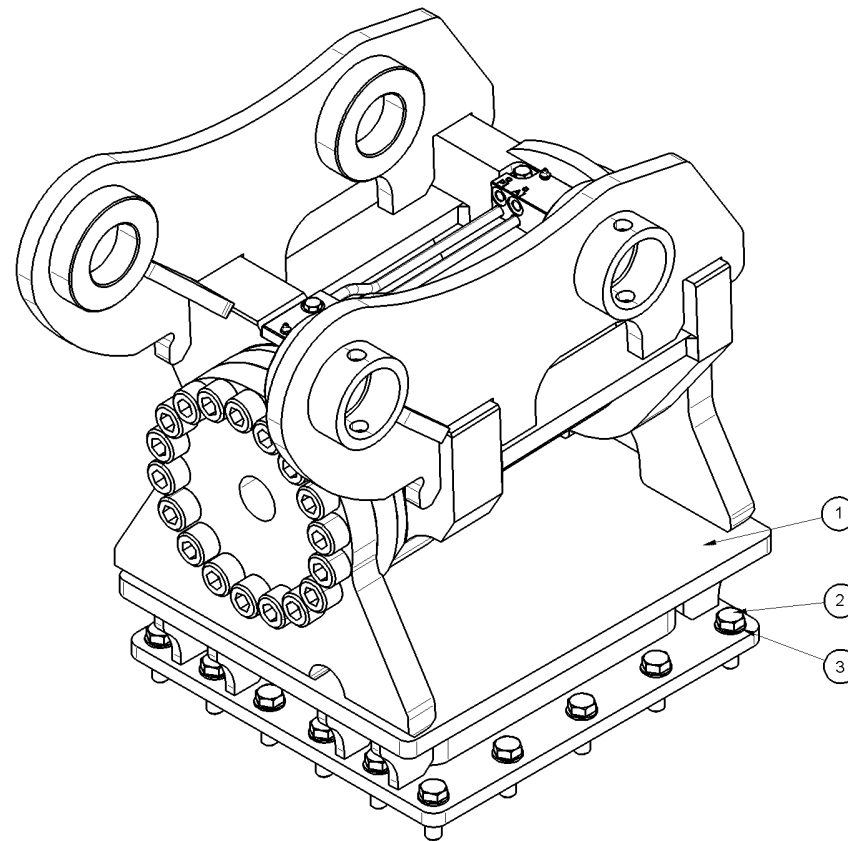

ANBAUPLATTE-TILT MOTOR - ATTACHMENT PLATE-TILT MOTOR
 PLAQUE DE MONTAGE-TILT MOTEUR - 41384104/00

41384104/00

Stücklistennummer / Piece Number / Liste de Pièces / Номер



Pos.	Bestell-Nr. Stock Number Numéro de Commande Номер товара	Menge Amount Quantité Количество	Beschreibung	Description	Description	Описание
1	41384052/00	1,000	ANBAUPLATTE-TILT MOTOR	ATTACHMENT PLATE-TILT MOTOR	PLAQUE DE MONTAGE-TILT MOTEUR	
2	 01.10.20060.C.V	18,0-00	SKT-SCHRAUBE M20X60 10.9	SCREW M20X60 DIN 933	SCREW M20X60 DIN 933	
3	 05.01.21	18,0-00	SCHEIBE ISO 7090-21-200HV	WASHER B21 DIN 125 GALVANIZED	WASHER B21 DIN 125 GALVANIZED	

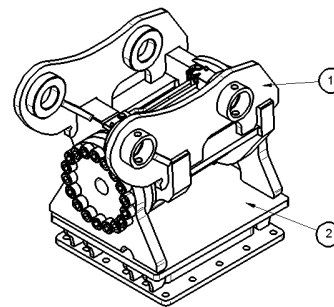

ANBAUPLATTE-TILT MOTOR - ATTACHMENT PLATE-TILT MOTOR
PLAQUE DE MONTAGE-TILT MOTEUR - 41384052/00

41384052/00

Stücklistennummer / Piece Number / Liste de Pièces / Номер



Pos.	Bestell-Nr. Stock Number Numéro de Commande Номер товара	Menge Amount Quantité Количество	Beschreibung	Description	Description	Описание
------	---	---	--------------	-------------	-------------	----------

1	28050095/00	1,000	MB TILT-MOTOR	MB TILT-MOTOR	MB TILT-MOTEUR	
---	-------------	-------	---------------	---------------	----------------	--

Index / Index / Index / Индекс

Bestell-Nr. Stock Number Numéro de Commande Номер заказа	Pos.	Seite	Bestell-Nr. Stock Number Numéro de Commande Номер заказа	Pos.	Seite	Bestell-Nr. Stock Number Numéro de Commande Номер заказа	Pos.	Seite
01.10.06016	90	227	01.10.16050	60	147	013.03.0.01/00	110	85
01.10.10025	30	27	01.10.16050	60	151	02.01.08/A	120	59
01.10.10025	20	29	01.10.16055	110	63	03.01.12	130	59
01.10.10025	30	31	01.10.16060	50	189	03.01.20	120	45
01.10.10025	30	33	01.10.16065	40	47	03.02.08	20	161
01.10.10025	20	35	01.10.16065	110	77	03.02.08	20	165
01.10.10025	120	141	01.10.16075	210	59	03.02.08	20	173
01.10.10025	50	153	01.10.16080	100	77	03.02.08	20	177
01.10.10030	120	51	01.10.20060.C.V	30	237	03.02.12	80	155
01.10.10035	5	21	01.10.20060.C.V	2	241	03.02.12	90	169
01.10.10035	10	25	01.20.08050	30	161	03.02.16	30	147
01.10.10035	20	27	01.20.08050	30	165	03.02.16	30	151
01.10.10035	30	29	01.20.08050	30	173	03.02.16	60	189
01.10.10035	20	31	01.20.08050	30	177	03.03.20.S.C	90	209
01.10.10035	20	33	01.20.16040.C	8	201	03.15.06	30	39
01.10.10035	30	35	01.21.16050.C	9	201	05.01.06	100	227
01.10.10035	30	37	01.21.16050.C	100	209	05.01.10	8	21
01.10.10045	140	55	01.30.16035.C.V	110	57	05.01.10	110	139
01.10.12030	60	17	01.40.06016.C.V	7	21	05.01.10	40	153
01.10.12030	90	155	01.40.06016.C.V	20	39	05.01.13	40	17
01.10.12030	70	169	01.80.20.S.155.C	80	209	05.01.13	140	59
01.10.12030	40	191	013.01.0.01/C	10	49	05.01.13	30	191
01.10.12030	30	197	013.01.0.01/C	10	53	05.01.13	40	197
01.10.12035	50	17	013.01.0.02/00	20	49	05.01.17	40	147
01.10.12040	100	63	013.01.0.03/00	30	49	05.01.17	40	151
01.10.12040	130	69	013.01.0.03/00	50	53	05.01.21	20	237
01.10.14055.C.V	150	141	013.01.0.04/00	40	49	05.01.21	3	241
01.10.16035	100	57	013.01.2.00/00	10	47	05.04.06	40	39
01.10.16040	120	55	013.01.2.05/A	50	49	05.04.10	6	21
01.10.16045	150	93	013.01.2.05/A	60	53	05.04.10	40	27
01.10.16045	140	107	013.02.3.00/00	20	47	05.04.10	40	29
01.10.16045	50	147	013.02.3.03/00	30	53	05.04.10	40	31
01.10.16045	50	151	013.02.3.04/00	40	53	05.04.10	40	33
01.10.16050	120	79	013.02.3.20/00	20	53	05.04.10	40	35

Index / Index / Index / Индекс

Bestell-Nr. Stock Number Numéro de Commande Номер заказа	Pos.	Seite	Bestell-Nr. Stock Number Numéro de Commande Номер заказа	Pos.	Seite	Bestell-Nr. Stock Number Numéro de Commande Номер заказа	Pos.	Seite
05.04.10	20	37	14.03.002/00	60	49	20.04.00011/00	10	129
05.04.13	150	59	14.05.ISKD060/00	70	67	20.04.00014/00	20	181
05.04.13	70	155	14.05.ISKD080/00	80	49	20.04.00016/00	30	129
05.04.13	80	169	14.05.ISKD080/00	80	53	20.04.00016/00	30	135
05.04.17	160	59	14.05.ISKD080/00	90	85	20.04.00021/00	30	181
05.04.17	40	189	16.01.A030	50	61	20.04.00030/00	10	181
05.10.060.17.0.J	140	93	16.01.A050	100	67	20.04.00035/00	20	129
05.10.070.17.5.J	130	93	16.01.A070	70	85	20.04.00035/00	20	135
05.10.070.17.5.J	130	107	16.01.J090	140	69	20.04.00061/00	10	135
06.04.007.16/00	40	227	16.01.J120	40	85	20.29.001/00	40	63
07.02.10	130	55	16.01.J160	100	49	20.29.002/00	20	139
07.02.12	80	63	16.01.J160	100	53	20.29.005/A	50	77
07.02.12	140	141	18.030.042.1	180	59	20.29.005/A	30	139
07.02.14	130	141	18.050.062.1	120	93	20.41.001/00	60	139
07.02.16	50	47	18.065.085.1	80	91	20.41.002/00	70	139
07.02.16	90	63	18.065.085.1	80	105	20.60.045/A	10	139
07.02.16	90	77	18.065.085.1	20	119	20.80.030.03	10	75
07.03.12	120	69	18.065.085.2	90	91	20.80.134.02	10	89
09.14.09.50	60	91	18.065.085.2	10	101	20.80.136/00	30	63
09.18.11.40	60	105	18.065.085.2	90	105	20.80.144/00	40	77
09.18.11.63	30	91	18.065.085.2	10	115	20.BUZ08L/00	30	185
09.18.11.63	30	105	19.02.21.010	80	67	20.BUZ18L/00	30	121
100302	20	227	19.03.144.00.3.00	90	49	20.BUZ18L/00	30	125
11.23.015/00	30	11	19.03.144.00.3.00	90	53	20.EWV08L/00	80	139
12.30.34.25/00	170	59	20.02.00464/00	50	129	20.EWV08S	90	139
12.40.44.30/00	50	155	20.02.00464/00	40	135	20.EWV18L.45/00	50	121
12.40.44.30/00	50	169	20.02.00528/00	60	77	20.EWV18L.45/00	50	125
13.A.0001/00	60	67	20.02.00559/00	60	63	20.GEV06L.M10-1/00	10	231
13.A.0002/00	80	85	20.02.00560/00	70	63	20.GEV06LL.M10-1/00	30	227
13.A.0004/00	70	49	20.02.00562/00	70	77	20.GEV08L.M12-1.5/00	40	139
13.A.0004/00	70	53	20.02.14.08.0450.B/00	50	185	20.GEV08L.M14-1.5/00	20	185
13.C.0006/00	40	61	20.02.14.18.1000.B/00	60	121	20.GEV08L1.4/00	10	185
13.C.0096/00	60	85	20.02.14.18.1000.B/00	60	125	20.GEV08S.M14-1.5/00	50	139
14.0006.02/00	90	67	20.04.00011.01	10	133	20.GEV18L.M18-1.5/00	10	121

Index / Index / Index / Индекс

Bestell-Nr. Stock Number Numéro de Commande Номер заказа	Pos.	Seite	Bestell-Nr. Stock Number Numéro de Commande Номер заказа	Pos.	Seite	Bestell-Nr. Stock Number Numéro de Commande Номер заказа	Pos.	Seite
20.GEV18L.M22-1.5/00	20	121	41408355/00	6	201	550.01.03.01.00/00	13	15
20.GEV18L.M22-1.5/00	20	125	41408356/00	5	201	550.06.00.00.00/B	12	9
20.GEV18L.M26-1.5/00	10	125	42.10.40.11	30	17	550.06.00.01.00/00	13	9
20.RV1.1-4.0.2/00	31	11	450.02.21.01.00/B	10	63	550.06.00.20.00/01	10	147
20.UEM08L/00	40	185	451.10.05.00.01/00	30	153	550.06.00.21.00/01	20	147
20.UEM18L/00	40	121	46.BCS01/01	6	203	550.06.00.24.00/00	10	151
20.UEM18L/00	40	125	46.BCS02/00	4	201	550.06.00.25.00/00	20	151
20.VS12.1.5/00	100	139	46.UPTS01/03	20	211	551.01.00.90.00/00	10	13
20.VS14.1.5/00	20	153	46.UPTS02/A	40	209	551.01.17.01.00/00	8	13
24.A.06.100	80	227	46.UPTS04/A	50	209	551.01.17.21.00/B	10	37
24.A.10.100	110	49	46.UPTS04/A	10	215	551.02.01.20.00/C	20	57
24.A.10.100	110	53	46.UPTS04/A	10	219	551.02.05.02.00/A	20	63
24.A.10.100	190	59	46.UPTS05/B	60	209	551.02.05.02.01/A	20	67
24.A.10.100	50	63	46.UPTS06/B	70	209	551.02.05.22.00/03	10	67
24.A.10.100	80	77	48.01.280.4/00	40	91	551.03.00.00.02/00	10	207
24.A.10.100	70	227	48.01.280.4/00	40	105	551.03.00.02.00/00	22	9
24.C.10.100	60	47	48.01.315.4/00	10	91	551.07.00.00.01/00	10	197
25.01.010.04	110	67	48.01.315.4/00	10	105	551.07.00.00.02/00	20	191
25.01.010.04	50	85	480.01.04.20.00/01	1	21	551.07.00.00.02/00	20	197
28044157/01	60	61	480.01.04.20.01/01	10	23	551.07.01.00.00/A	10	195
28044429/00	70	61	49.1.3020	10	97	551.07.01.01.00/A	20	189
28044430/00	80	61	49.1.3020	10	111	551.07.01.01.01/00	10	191
28050095/00	1	243	49.1.3525	10	95	551.10.01.01.00/A	30	155
41233326/03	1	233	49.1.3525	20	95	551.10.01.01.00/A	40	155
41248138/00	10	223	49.1.3525	10	109	551.10.01.01.00/A	30	169
41248141/00	24	11	49.1.3525	20	109	551.10.01.01.00/A	40	169
41323484/00	30	47	49.50.3020/00	50	91	551.10.01.01.01/A	10	161
41324423/00	30	61	49.65.3020/00	50	105	551.10.01.01.01/A	10	165
41325311/00	10	57	49.65.3525/00	20	91	551.10.01.01.01/A	10	173
41368767/01	7	201	49.65.3525/00	20	105	551.10.01.01.01/A	10	177
41375566/00	2	233	50.2.2187.B.Z.2	70	91	560.01.00.00.00/01	1	7
41384052/00	1	241	50.2.2187.B.Z.2	70	105	560.01.01.00.00/D	11	13
41384104/00	29	11	55.01.G.153633/00	200	59	560.01.01.21.00/B	20	43
41387729/00	2	13	550.01.02.01.00/00	12	15	560.01.12.00.00/00	3	13

Index / Index / Index / Индекс

Bestell-Nr. Stock Number Numéro de Commande Номер заказа	Pos.	Seite	Bestell-Nr. Stock Number Numéro de Commande Номер заказа	Pos.	Seite	Bestell-Nr. Stock Number Numéro de Commande Номер заказа	Pos.	Seite
560.01.12.00.01/00	10	27	560.15.00.01.00/A	17	9	750.25.1.01/A	100	85
560.01.12.01.00/00	5	13	560.15.00.02.00/A	7	7	752.06.2.05	120	107
560.01.12.01.01/00	10	31	560.15.00.03.00/A	9	7	753.32.1.01/D	2	201
560.01.12.02.00/00	6	13	560.15.00.04.00/A	8	7	753.32.1.01/D	20	209
560.01.12.02.01/00	10	33	560.15.00.05.00/A	10	7	754.03.00.00.01/I	1	205
560.01.12.03.00/00	4	13	560.15.00.06.00/B	11	7	754.03.00.00.01/I	1	213
560.01.12.03.01/00	10	29	560.20.00.00.00/A	26	11	754.20.5.02/A	110	91
560.01.12.04.00/00	7	13	560.32.00.00.00/A	28	11	754.20.5.02/A	110	105
560.01.12.04.01/00	10	35	560.32.00.00.01/00	10	237	754.20.5.08/00	20	99
560.01.19.00.00/00	1	13	61.1.03/00	30	85	754.20.5.08/00	20	113
560.01.19.00.01/00	20	17	62.0.010.01.0250/00	60	227	796.6.2.66/B	100	91
560.01.19.20.00/00	10	17	62.0.010.01.0600/00	50	227	796.6.2.66/B	100	105
560.01.19.20.01/00	10	19	650.01.15.00.01/00	4	21	796.9.4.17.B	10	99
560.01.19.20.02/00	20	19	650.01.22.00.00/00	9	13	796.9.4.17.B	10	113
560.02.00.00.00/01	2	7	650.02.00.03.01/00	30	77	84.110.03.12/00	20	41
560.02.00.01.00/A	3	7	650.02.01.00.01/00	30	57	85.003.001/04	10	41
560.02.00.02.00/A	4	7	650.02.02.02.00/01	10	85	85.01.111/00	3	233
560.02.04.02.00/00	6	7	650.02.03.03.00/A	10	77	85.01.13/00	4	235
560.02.04.03.00/00	5	7	650.02.03.03.01/01	20	85	85.01.132/02	20	223
560.07.00.00.00/00	20	9	650.02.04.27.00/A	40	57	85.01.133/02	20	207
560.07.00.01.00/00	19	9	650.02.04.27.01/00	50	57	85.01.138/01	1	235
560.07.00.01.01/A	30	189	650.02.04.27.06/A	60	57	85.01.148/01	2	235
560.07.00.20.00/00	10	189	650.02.04.27.09/00	70	57	85.01.151/01	90	57
560.10.00.00.00/00	16	9	650.02.04.28.00/00	80	57	85.01.17/00	6	235
560.10.00.01.00/00	15	9	650.10.01.20.03/00	40	159	85.01.20/00	9	235
560.10.00.20.00/00	10	155	652.02.00.01.02/A	20	77	85.01.21/00	3	235
560.10.00.20.00/00	10	169	71.001.155/00	10	39	85.01.22/00	7	235
560.10.00.21.00/00	20	169	729.01.16.00.01/A	3	21	85.01.23/00	5	233
560.10.00.22.00/00	20	155	729.10.00.00.03/A	10	227	85.01.27/00	8	235
560.10.03.00.00/00	14	9	740.02.03.00.02/A	30	67	85.01.28/00	5	235
560.10.03.00.01/00	10	153	740.03.00.00.01/01	3	201	85.01.33/A	4	233
560.11.00.00.00/02	27	11	740.03.00.00.01/01	30	209	857.03.00.63.00/00	23	11
560.14.00.00.00/00	25	11	742.10.01.00.04/00	80	157	857.03.00.64.00/01	21	9
560.15.00.00.00/A	18	9	742.10.01.00.04/00	80	171	857.03.01.63.00/01	10	209

Index / Index / Index / Индекс

<small>Bestell-Nr. Stock Number Numéro de Commande Номер заказа</small>	Pos.	Seite
857.03.01.64.00/02	1	201
857.03.03.28.01/00	30	211
857.03.03.28.02/00	5	203
991.05.04.00.01/00	40	67
991.05.04.00.02/00	50	67
991.10.42.00.00/00	60	155
991.10.42.00.00/00	60	169